

20
12

PRODUCT CATALOG



In our 30 years of business, Hunter Industries has come a long way. And we couldn't be happier with where we are.

When Edwin J. Hunter founded Hunter Industries in 1981, he envisioned a company that would become one of the leading irrigation manufacturers in the world. But he knew that in order to get there, he had to deliver more than just efficient, high-quality products. He needed to give his customers more. More support, more technical resources, more product training, market-stabilizing prices, and generous warranties. He knew that irrigation customers didn't just need a manufacturer. They needed a partner.

Some 30 years later, with four brands under our corporate banner, a sales force spanning 80 countries, and over 100 product lines, the Hunter promise of partnership still stands as strong as ever. And it's included with every product listed in the ensuing pages.

In the field, at the office, or in the factory, we're built to support our customers in every way, every day. And that's exactly how we'll continue to work moving forward.

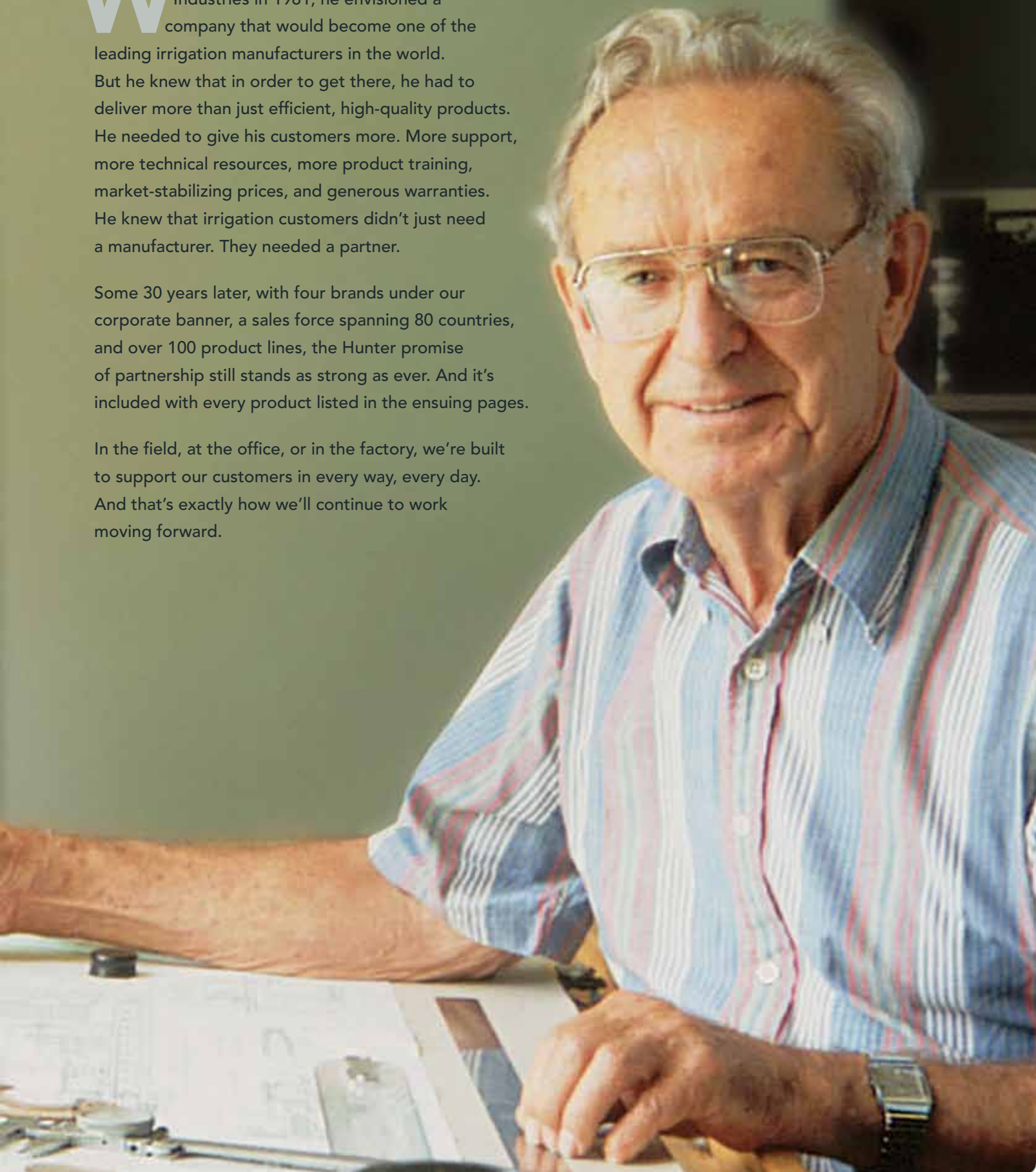

DELIVERING THE

From the top down, Hunter employees are trained to understand our customers' needs

SUPPORT YOU

and everyone is dedicated to doing their part.

NEED



When you choose Hunter, you get more than just innovative irrigation products. You get access to an accomplished team of irrigation professionals who are completely dedicated to ensuring that our distributors, customers, and end-users are completely satisfied with our products and service. We've engineered our business this way because we understand that our customers rely on us for far more than just efficient products. They need training, field support, marketing support, and most importantly, a manufacturer they can rely on and trust.

PUTTING PEOPLE FIRST

We're able to deliver on our promise of industry-leading support because the people we employ aren't just sales, marketing, or engineering people, they're irrigation people. From the top down, Hunter employees are trained to understand our customers' needs, and everyone is dedicated to doing their part.

FROM THE GROUND UP

HUNTER AND FX LUMINAIRE

FX
LUMINAIRE

A Marriage of Strengths...
**A FUTURE
OF EFFICIENT
INNOVATION**



FEATURED IN THIS PHOTO: An FX field manager helps a contractor install the FX DemiLite (DL) pathlight at a home in San Marcos, California.



SP SaguaroPetite



MU MacchiaUltimo®



RS ReflectoreStellato®



NP NuitPartenaire

“Now, as FX has become an integrated branch of Hunter, we’re proud to say that we’re fully equipped to deliver the same promise of excellent service and support with every FX purchase as well.”

RAISING THE BAR IN OUTDOOR LIGHTING

When FX Luminaire became a part of Hunter Industries in 2009, the plan was to take the efficient FX line and combine it with Hunter’s deep infrastructure. Another part of the plan was to infuse the FX brand with Hunter’s company-wide dedication to customer service, education, and supporting resources. Now, as FX has become an integrated branch of Hunter, we’re proud to say that we’re fully equipped to deliver the same promise of excellent service and support with every FX purchase as well.

LUMINEUX LEADS THE WAY IN LED TECHNOLOGY

Beyond integrating FX into Hunter’s vast infrastructure, the FX team has also been busy developing the innovation-stocked Lumineux line of all LED fixtures. With the most advanced LED technology ever developed, Lumineux lamps offer smarter, more radiant LED shine regardless of application.

BELOW: NP, PB, LF, and JB are part of the efficient Lumineux LED line



PB PanerBâton



LF LouverFenêtre



JB JubiléBijou



LX Transformer

Hunter®

“At Hunter, one of our business philosophies is that we succeed only when our customers succeed.”

WE SUCCEEDED
TOGETHER



At Hunter, one of our core business philosophies is that we succeed only when our customers succeed. With that in mind, we developed a partnership program designed to provide our loyal customers with valuable rewards for choosing Hunter products. With every Hunter or FX Luminaire purchase, preferred contractors earn points that can be used to redeem rewards such as cash, business tools, and all kinds of Hunter merchandise.

Contractors can get started in this outstanding program by contacting an authorized Hunter Distributor, calling 877-888-0167, or emailing hunterpreferred@hunterindustries.com.



Hunter®

Here, an MP Rotator undergoes a water uniformity test at our corporate headquarters in San Marcos, CA.

“Our tradition of quality and innovation, instilled by Edwin Hunter, is central to everything we do.”

— Taken from Hunter’s Mission and Values Statement

A promise of Quality, DELIVERED EVERY DAY

Every Hunter Industries product is engineered with the highest possible level of quality in mind. To ensure our promise of quality is delivered throughout our production process, every product goes through a rigorous testing process at our state-of-the-art quality assurance facility and in the field at test sites.

This rigorous testing system applies to our entire line of irrigation products as well as FX Luminaire and Lumineux products.



WHAT'S NEW



37 ROTORS

SYNTHETIC TURF ROTOR

The ST Rotors take Hunter's legendary rotor prowess and deliver durable, efficient long-range coverage for synthetic turf applications.



84 CONTROLLERS

NODE

The next generation battery-operated controller is here. The small, durable NODE offers 6-station control and works with one or two 9V batteries.



89 CENTRAL

GPRS

Adds GPRS wireless mobile communications as an option for ACC Com modules and controllers in IMMS systems.



89 CENTRAL

ETHERNET

Adds Ethernet (TCP/IP) as a communications option for ACC Com modules and controllers in IMMS systems.



BLUE PRINT OF AN EFFICIENT IRRIGATION SYSTEM

A properly designed, managed, and maintained irrigation system is an essential tool for a healthy, functional landscape. The Hunter products featured here will maximize the effectiveness of the water you use.

PGP Ultra and I-20



Hunter rotors are the best choice when watering a large turf or landscape area. Our nozzles are engineered for excellent water distribution at low precipitation rates to keep landscape looking its best, while using water efficiently.

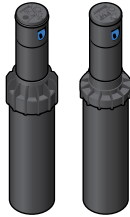

Pro-Spray and Nozzles



Smaller areas require spray sprinklers for proper watering. Hunter's spray bodies are available with pressure regulation to ensure the most accurate watering of any landscape. Hunter's spray nozzles are meticulously engineered and tested to provide even watering and efficient use.

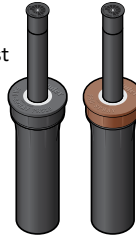

MP Rotator



The ultimate solution for small-to medium-sized areas, this high-efficiency, low precipitation rate sprinkler offers unmatched performance and proven water savings up to 30% over sprays.

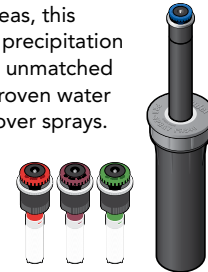

PGV, ICV and Drip Control Kits



Hunter's trusted valve line ensures system reliability and accuracy. Accu-Sync can be used on systems with excess pressure to extend the life of the system components and provide the correct operating pressure to the sprinklers. Drip zone kits are equipped with pressure regulators and filters to provide drip and micro irrigation components with the correct pressure and contaminant-free water.

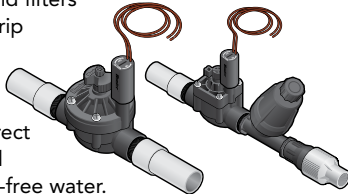

Drip/Micro Irrigation



Drip irrigation is an efficient choice for certain landscape situations. It applies water directly to the root zone area of landscape plants, helping to limit excess irrigation. Micro spray emitters can be used to cover small planting beds efficiently.

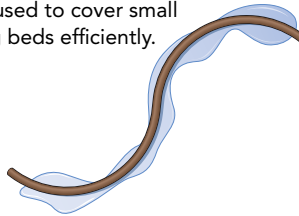

Pro-C/I-Core



The correct controller for the job is essential to meet the needs of any landscape, from unpredictable weather to municipal watering requirements. Having a customizable controller that is sensor compatible is the first step to a water-efficient system.

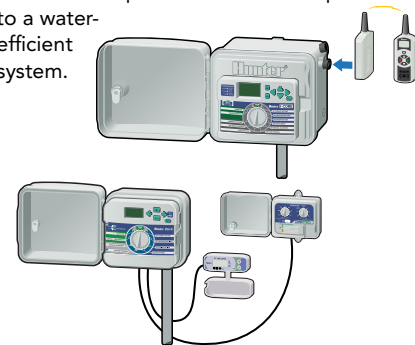

Flow-Click/HFS



Flow sensors prevent systems from running when there is a leak or broken component. The Flow-Click will work with most Hunter controllers to suspend irrigation, and the HFS is compatible with specific Hunter controllers to monitor overflow and provide flow totaling for better management.

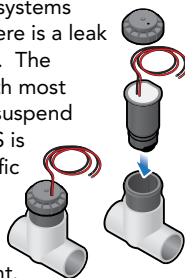

Solar Sync



Solar Sync monitors weather, working with the controller to adjust the system for changing conditions, ensuring water is not wasted.

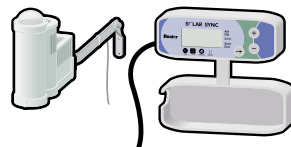

LEGEND









-  SPRAY HEADS
-  ROTORS
-  MP ROTATORS
-  CONTROL VALVES
-  LANDSCAPE DRIPLINE
-  WEATHER SENSOR
-  FLOW SENSOR
-  CONTROLLER



TABLE OF CONTENTS

ROTORS

SPRAYS/NOZZLES

MP ROTATOR

VALVES

CONTROLLERS

Advanced Features ... 17	Advanced Features ... 41	MP Rotator 57	Advanced Features ... 61	Advanced Features ... 73
PGJ 19	PS Ultra 43		Accu-Sync™ 62	X-Core 75
SRM 20	Pro-Spray® 45		SRV 63	PCC 76
PGP 21	PRS30 46		PGV 64	Pro-C 77
PGP Ultra 23	PRS40 47		PGV Jar-Top 65	I-Core 78
I-20 25	Pro Adjustable Nozzles 49		PGV-ASV 66	Dual 79
I-25 27	Pro-Spray® Fixed Arc Nozzles 51		ICV 67	ACC 80
I-35 29	Nozzles 53		IBV 68	ACC-99D 81
I-40 31	Nozzles/Bubblers 54		Quick Couplers 69	HFS 82
I-60 33				ICD-HP 82
I-90 35				XC Hybrid 83
ST System Rotors 37				Node 84
ST System Accessories 38				WVS 85
				Pump Start Relay 85
				Roam 86
				ICR 86



CENTRAL

SENSORS

DRIP/MICRO

ACCESSORIES

TECHNICAL

IMMS 3.0 89	Mini-Clik® 93	PLD 101	Accessories 107	Replacement Guide 109
	Freeze-Clik® 93	Micro Irrigation 102		Precipitation Rates 113
	Wind-Clik® 94	Drip Zone Control Kits 103		Slope Equivalents/ Irrigation 114
	Mini Weather Station 94	Root Zone Watering System 105		Height of Spray 115
	Rain-Clik™ 95			17 mm PLD Charts .. 117
	Flow-Clik™ 96			Drip Zone Control Kit Charts 118
	Solar Sync 97			Conversion Factors .. 119
	ET System 98			Pressure Loss Chart.. 120
				Friction Loss Charts.. 121
				Wire Data 128
				Wire Sizing 129
				Additional Data 130



TALK ABOUT A REVOLUTION. When Edwin Hunter invented the rotor that would become the blockbuster PGP in the mid-1980s, the industry would be forever changed. Now with a fully expanded portfolio to meet any challenge, **Hunter rotors are the embodiment of a decades-old legacy married with forward-thinking innovation.**

ROTORS

COMPARISON CHART

	PGJ	SRM	PGP	PGP ULTRA	I-20	I-25	I-35	I-40	I-60	I-90	ST SYSTEM
APPLICATIONS											
Spacings 15' to 37'	•	•		•	•						
Spacings 25' to 45'			•	•	•						
Spacings more than 45'						•	•	•	•	•	•
Residential	•	•	•	•	•						
Commercial/institutional				•	•	•	•	•	•	•	
Athletic fields					•	•	•	•		•	•
High vandalism areas				•	•	•	•	•		•	
Low pressure systems	•	•	•	•			•		•		
Riser-mounted sprinklers	•			•	•						
Ground cover and/or shrubs	•		•	•	•						
Reclaimed water ID cover	•			•	•	•	•	•	•	•	

ADVANCED FEATURES

AUTOMATIC ARC RETURN
 This feature returns to the original arc regardless of where the turret is turned. This ensures vandal protection in any environment.
 PGP Ultra, I-20, I-25, I-35, I-40

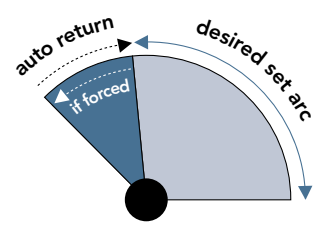

NON-STRIPPABLE DRIVE
 The patent-pending, non-strippable, vandal proof drive mechanism enables the turret to be turned without causing damage.
 PGP Ultra, I-20, I-25, I-35, I-40



PART- AND FULL-CIRCLE IN ONE MODEL
 Patented non-reversing 360 for part- and full-circle in one model, from 50 to 360 degrees.
 PGP Ultra, I-20, I-25, I-35, I-40

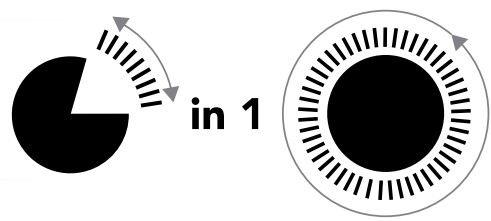

HEADED AND SLOTTED SET SCREW
 Use a slotted screwdriver or the Hunter wrench for easier and simpler adjustments as needed.
 PGJ, PGP Ultra, I-20, I-35



FLOSTOP™ CONTROL
 FloStop closes the flow of water from individual sprinkler heads while the system is running. This is ideal for changing nozzles or turning off specific heads during maintenance and construction.
 I-20, I-35



OPPOSING NOZZLE 360° MODEL

The opposing nozzle design offers excellent water distribution. With primary and secondary nozzles on opposing sides of the turret, streams arc in opposite directions as the sprinkler rotates for outstanding midrange and close-in watering.

I-40, I-90

**COLOR CODED NOZZLES**

Nozzles are easier to differentiate in the field for simple installation and quick organization.

I-25, I-35, I-60, I-90

**STAINLESS STEEL RISER**

For unforgiving soil conditions, unpredictable climates, or heavy foot traffic, stainless steel is the best choice.

Standard on I-40 and I-60; optional on I-20, I-25, and I-35

**RECLAIMED WATER ID**

Purple caps indicate where non-potable irrigation water is being used.

PGJ, PGP Ultra, I-20, I-25, I-35, I-40, I-60, I-90

**DRAIN CHECK VALVE**

As air in lines can cause long-term damage to rotors and plumbing, the drain check valve keeps lines from draining when the system is shut off. This saves water, reduces liability, and increases system life.

PGJ, PGP Ultra, I-20, I-25, I-35, I-40, I-60, I-90



PGJ

APPLICATION

Residential

RADIUS

15' to 37'

FLOW RATE

0.64 to 5.3 GPM

THE PGJ HAS ALL THE BENEFITS OF A ROTOR IN A COMPACT, SPRAY-SIZED PACKAGE.

FEATURES

- Models: Shrub, 4", 6", 12"
- Arc setting: 40 to 360 degrees
- Nozzle choices: 8
- Nozzle range: 0.75 to 5.0
- Standard factory installed nozzle: 2.0 only
- Factory installed rubber cover
- Through-the-top arc adjustment
- Quick check arc mechanism
- Water lubricated gear-drive
- Warranty period: 2 years

ADVANCED FEATURES

- Headed and slotted set screw
- Reclaimed water ID (optional)
- Drain check valve (optional)
- = Detailed descriptions on pages 17 and 18

OPERATING SPECIFICATIONS

Radius: 15' to 37'
 Flow rate: 0.64 to 5.3 GPM
 Recommended pressure range: 30 to 50 PSI
 Operating pressure range: 20 to 100 PSI
 Precipitation rates: 0.6 in/hr approx.
 Nozzle trajectory: 14 degrees approx.

FACTORY INSTALLED OPTIONS

Drain check valve (up to 7' of elevation)
 Reclaimed water ID cover

USER INSTALLED OPTIONS

Drain check valve (up to 7' of elevation; P/N 462078)

PGJ Nozzle Performance Data

Nozzle	Pressure PSI	Radius ft.	Flow GPM	Precip in/hr	
				■	▲
.75	30	15	0.64	0.55	0.63
	40	16	0.75	0.56	0.65
	50	17	0.85	0.57	0.65
1.0	30	18	0.85	0.51	0.58
	40	19	1.0	0.53	0.62
	50	19	1.1	0.59	0.68
1.5	30	21	1.3	0.57	0.66
	40	22	1.5	0.60	0.69
	50	22	1.7	0.68	0.78
2.0	30	24	1.7	0.57	0.66
	40	25	2.0	0.62	0.71
	50	25	2.3	0.71	0.82
2.5	30	27	2.2	0.58	0.67
	40	28	2.5	0.61	0.71
	50	28	2.8	0.69	0.79
3.0	30	30	2.5	0.53	0.62
	40	31	3.0	0.60	0.69
	50	31	3.4	0.68	0.79
4.0	30	33	3.7	0.65	0.76
	40	34	4.0	0.67	0.77
	50	34	4.3	0.72	0.83
5.0	30	36	4.7	0.70	0.81
	40	37	5.0	0.70	0.81
	50	37	5.3	0.75	0.86

Note: All precipitation rates calculated for 180 degree operation. For the precipitation rate for a 360 degree sprinkler, divide by 2. Optimum nozzle performance shown in bold.

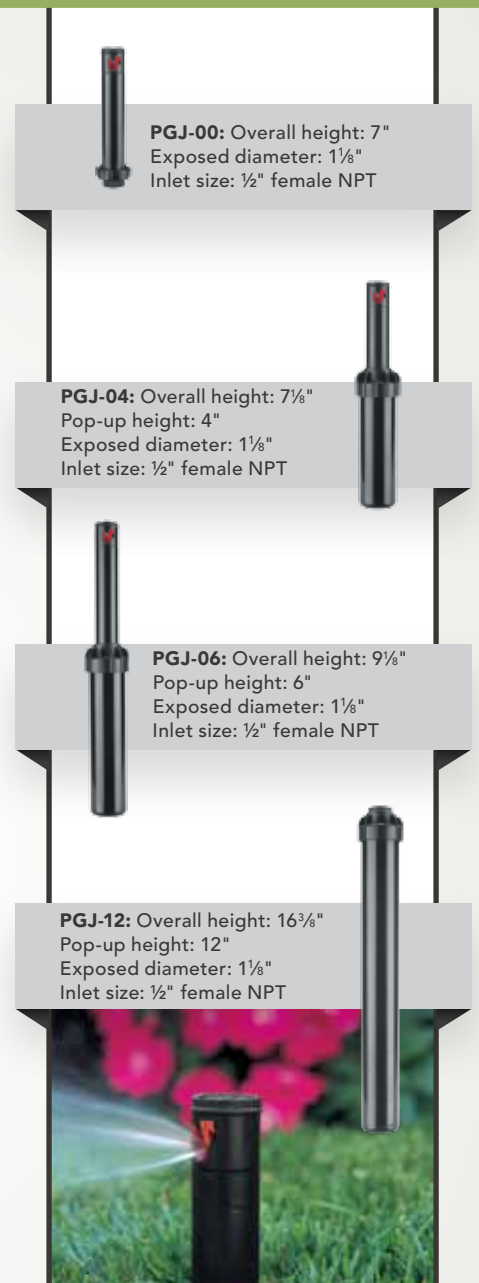

SPECIFICATIONBUILDER

hunterindustries.com/PGJ

MODELS	STANDARD FEATURES	FEATURE OPTIONS
PGJ-00 = Shrub	Adjustable arc, 8 standard nozzles	R
PGJ-04 = 4" pop-up		V, R
PGJ-06 = 6" pop-up		V, R
PGJ-12 = 12" pop-up		V, R

V = Drain check valve
 R = Drain check valve and reclaimed water ID

EXAMPLES

PGJ-04	4" pop-up, adjustable arc
PGJ-06 - V	6" pop-up, adjustable arc, with drain check valve
PGJ-12 - R	12" pop-up, adjustable arc, with drain check valve and reclaimed water ID



Purple reclaimed rubber cover. Available as a factory-installed option on all models.

SRM

APPLICATION

Residential

RADIUS

15' to 30'

FLOW RATE

0.42 to 3.4 GPM

THIS SHORT RANGE ROTOR OFFERS LOW PRECIPITATION RATES FOR APPLICATIONS THAT NORMALLY CALL FOR SPRAYS.

FEATURES

- Model: 4"
- Arc setting: 40 to 360 degrees
- Nozzle choices: 6
- Nozzle range: 0.50 to 3.0
- Standard factory installed nozzle: 3.0 only
- Through-the-top arc adjustment
- Quick check arc mechanism
- Water lubricated gear-drive
- Warranty period: 2 years

OPERATING SPECIFICATIONS

Radius: 15' to 30'

Flow rate: 0.42 to 3.4 GPM

Recommended pressure range: 30 to 50 PSI

Operating pressure range: 20 to 100 PSI

Precipitation rates: 0.45 in/hr approx.

Nozzle trajectory: 18 degrees approx.

USER INSTALLED OPTIONS

Drain check valve
(up to 7' of elevation; P/N 462078)

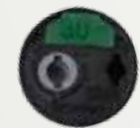

Top view

SRM Nozzle Performance Data

Nozzle	Pressure PSI	Radius ft.	Flow GPM	Precip in/hr	
				■	▲
.50	30	15	0.42	0.36	0.41
	40	16	0.50	0.38	0.43
	50	17	0.58	0.39	0.45
.75	30	17	0.64	0.43	0.49
	40	18	0.75	0.45	0.51
	50	19	0.85	0.51	0.58
1.0	30	19	0.85	0.45	0.52
	40	20	1.0	0.48	0.56
	50	20	1.1	0.53	0.61
1.5	30	23	1.3	0.47	0.55
	40	24	1.5	0.50	0.58
	50	25	1.7	0.52	0.60
2.0	30	25	1.7	0.52	0.60
	40	26	2.0	0.57	0.66
	50	27	2.3	0.61	0.70
3.0	30	28	2.5	0.61	0.71
	40	30	3.0	0.64	0.74
	50	30	3.4	0.73	0.84

Note: All precipitation rates calculated for 180 degree operation. For the precipitation rate for a 360 degree sprinkler, divide by 2. Optimum nozzle performance shown in bold.



SRM-04: Overall height: 6 5/8"
Pop-up height: 4"
Exposed diameter: 1 1/8"
Inlet size: 1/2" female NPT

ROTORS

SPECIFICATIONBUILDER

hunterindustries.com/SRM

MODELS

STANDARD FEATURES

SRM-04 = 4" pop-up

Adjustable arc, 6 standard nozzles

EXAMPLE

SRM-04	4" pop-up, adjustable arc
---------------	---------------------------

PGP

APPLICATION

Residential

RADIUS

22' to 52'

FLOW RATE

0.5 to 14.1 GPM

AFTER THREE DECADES, THE WORLD'S BEST SELLING ROTOR IS STILL NUMBER ONE.

FEATURES

- Model: 4"
- Arc setting: 40 to 360 degrees
- Nozzle choices: 27 total
- Nozzle racks: #1 to #12 red, 1.5 to 8.0 blue, #4 LA to #10 LA gray
- Factory installed rubber cover
- Through-the-top arc adjustment
- Quick check arc mechanism
- Water lubricated gear-drive
- Warranty period: 2 years

ADVANCED FEATURES

- Low angle nozzle choices

OPERATING SPECIFICATIONS

Radius: 22' to 52'
 Flow rate: 0.5 to 14.1 GPM
 Recommended pressure range: 25 to 70 PSI
 Operating pressure range: 20 to 100 PSI
 Precipitation rates: 0.4 in/hr approx.
 Nozzle trajectory: Std = 25 degrees, Low angle = 13 degrees

FACTORY INSTALLED OPTIONS

Nozzles: #5 to #8 red, 1.5 to 4.0 blue

USER INSTALLED OPTIONS

Drain check valve (up to 4' of elevation; P/N 142300)



PGP-ADJ: Overall height: 7³/₈"
 Pop-up height: 4"
 Exposed diameter: 1³/₄"
 Inlet size: 3/4" female NPT



PGP-ATR
 Advanced Technology
 Replacement
 for impact rotors

SPECIFICATIONBUILDER

hunterindustries.com/PGP

MODELS	STANDARD FEATURES	NOZZLE OPTIONS
PGP-ADJ-B = 4" pop-up	Adjustable arc, with BLUE nozzle rack	1.5 to 4.0 = Factory installed nozzle number
PGP-ADJ = 4" pop-up	Adjustable arc, with RED nozzle rack	#5 to #8 = Factory installed nozzle number
PGP-ATR = Impact replacement	Adjustable arc, with RED nozzle rack	#7 = Factory installed nozzle number



EXAMPLES

PGP-ADJ	4" pop-up, adjustable arc
PGP-ADJ-B - 3.0	4" pop-up, adjustable arc, and 3.0 BLUE nozzle
PGP-ADJ - 07	4" pop-up, adjustable arc, and #7 RED nozzle

ROTORS

PGP CHARTS



PGP Red Standard Nozzle Performance Data (P/N 130900)

Nozzle	Pressure PSI	Radius ft.	Flow GPM	Precip in/hr	
				■	▲
1	30	28	0.5	0.12	0.14
	40	29	0.6	0.14	0.16
	50	29	0.7	0.16	0.19
	60	30	0.8	0.17	0.20
2	30	29	0.7	0.16	0.19
	40	30	0.8	0.17	0.20
	50	30	0.9	0.19	0.22
	60	31	1.0	0.20	0.23
3	30	30	0.9	0.19	0.22
	40	31	1.0	0.20	0.23
	50	31	1.2	0.24	0.28
	60	32	1.3	0.24	0.28
4	30	32	1.2	0.23	0.26
	40	33	1.4	0.25	0.29
	50	34	1.6	0.27	0.31
	60	34	1.8	0.30	0.35
5	30	34	1.6	0.27	0.31
	40	36	1.8	0.27	0.31
	50	38	2.0	0.27	0.31
	60	38	2.2	0.29	0.34
6	30	34	2.0	0.33	0.38
	40	36	2.4	0.36	0.41
	50	38	2.7	0.36	0.42
	60	38	2.9	0.39	0.45
7	30	34	2.6	0.43	0.50
	40	38	3.0	0.40	0.46
	50	40	3.4	0.41	0.47
	60	40	3.7	0.45	0.51
8	30	37	3.2	0.45	0.52
	40	39	3.7	0.47	0.54
	50	41	3.9	0.45	0.52
	60	42	4.6	0.50	0.58
9	30	38	3.6	0.48	0.55
	40	41	4.3	0.49	0.57
	50	44	5.2	0.52	0.60
	60	45	5.5	0.52	0.60
10	30	44	6.0	0.60	0.69
	40	46	6.8	0.62	0.71
	50	47	7.6	0.66	0.76
	60	49	8.2	0.66	0.76
11	30	46	8.0	0.73	0.84
	40	48	8.9	0.74	0.86
	50	50	9.8	0.75	0.87
	60	51	10.5	0.78	0.90
12	30	46	10.5	0.96	1.10
	40	48	11.9	0.99	1.15
	50	50	12.7	0.98	1.13
	60	52	14.1	1.00	1.16



PGP Blue Standard Nozzle Performance Data (P/N 665300)

Nozzle	Pressure PSI	Radius ft.	Flow GPM	Precip in/hr	
				■	▲
1.5	25	29	1.2	0.27	0.32
	35	31	1.4	0.28	0.32
	45	31	1.5	0.30	0.35
	55	32	1.8	0.34	0.39
	65	32	1.9	0.36	0.41
2.0	25	33	1.4	0.25	0.29
	35	33	1.7	0.30	0.35
	45	34	2.0	0.33	0.38
	55	34	2.1	0.35	0.40
	65	32	2.3	0.43	0.50
2.5	25	33	1.7	0.30	0.35
	35	35	2.1	0.33	0.38
	45	35	2.5	0.39	0.45
	55	35	2.6	0.41	0.47
	65	35	2.9	0.46	0.53
3.0	25	35	2.2	0.35	0.40
	35	36	2.7	0.40	0.46
	45	38	3.0	0.40	0.46
	55	39	3.4	0.43	0.50
	65	39	3.7	0.47	0.54
4.0	25	37	3.0	0.42	0.49
	35	39	3.5	0.44	0.51
	45	40	4.0	0.48	0.56
	55	41	4.5	0.52	0.60
	65	41	4.8	0.55	0.63
5.0	25	37	3.7	0.52	0.60
	35	39	4.5	0.57	0.66
	45	42	5.0	0.55	0.63
	55	42	5.7	0.62	0.72
	65	42	6.2	0.68	0.78
6.0	25	38	4.3	0.57	0.66
	35	40	5.6	0.67	0.78
	45	43	6.0	0.62	0.72
	55	44	6.7	0.67	0.77
	65	44	7.3	0.73	0.84
8.0	25	37	6.0	0.84	0.97
	35	41	7.0	0.80	0.93
	45	44	8.0	0.80	0.92
	55	46	9.0	0.82	0.95
	65	46	9.8	0.89	1.03



PGP Gray Low Angle Nozzle Performance Data (P/N 233200)

Nozzle	Pressure PSI	Radius ft.	Flow GPM	Precip in/hr	
				■	▲
4	30	22	1.4	0.56	0.64
	40	24	1.7	0.57	0.66
	50	26	1.8	0.51	0.59
	60	28	2.0	0.49	0.57
5	30	25	1.6	0.49	0.57
	40	27	1.9	0.50	0.58
	50	28	2.1	0.52	0.60
	60	30	2.3	0.49	0.57
6	30	27	2.1	0.55	0.64
	40	30	2.5	0.53	0.62
	50	33	2.8	0.49	0.57
	60	35	3.0	0.47	0.54
7	30	29	2.8	0.64	0.74
	40	32	3.1	0.58	0.67
	50	35	3.5	0.55	0.64
	60	37	3.8	0.53	0.62
8	30	31	3.4	0.68	0.79
	40	34	3.9	0.65	0.75
	50	37	4.4	0.62	0.71
	60	38	4.7	0.63	0.72
9	30	33	4.3	0.76	0.88
	40	37	5.0	0.70	0.81
	50	40	5.6	0.67	0.78
	60	42	6.1	0.67	0.77
10	40	38	6.5	0.87	1.00
	50	40	7.3	0.88	1.01
	60	42	8.0	0.87	1.01
	70	44	8.6	0.86	0.99

P Blank nozzle plug for turning off selected sprinklers during repairs, maintenance, etc.

Note: All precipitation rates calculated for 180 degree operation. For the precipitation rate for a 360 degree sprinkler, divide by 2. Optimum nozzle performance shown in bold.

PGP ULTRA

APPLICATION
Residential/Light Commercial

RADIUS
17' to 47'

FLOW RATE
0.36 to 14.8 GPM

THIS UPGRADE OF THE FIRST-CLASS PGP IS PACKED WITH NEW FEATURES.

FEATURES

- Models: Shrub, 4", 12"
- Arc setting: 50 to 360 degrees
- Nozzle choices: 22
- Nozzle racks: 1.5 to 8.0 blue, 2.0 LA to 4.5 LA gray, 0.50 to 3.0 black, 6.0 to 13.0 green
- Factory installed rubber cover
- Through-the-top arc adjustment
- Quick check arc mechanism
- Water lubricated gear-drive
- Warranty period: 3 years

ADVANCED FEATURES

- Automatic arc return
 - Non-strippable drive
 - Part- and full-circle in one model
 - Headed and slotted set screw
 - Reclaimed water ID (optional)
 - Drain check valve (optional)
 - Low angle nozzle choices
- = Detailed descriptions on pages 17 and 18

OPERATING SPECIFICATIONS

Radius: 17' to 47'
 Flow rate: 0.36 to 14.8 GPM
 Recommended pressure range: 25 to 70 PSI
 Operating pressure range: 20 to 100 PSI
 Precipitation rates: 0.4 in/hr approx.
 Nozzle trajectory: Std = 25 degrees, Low angle = 13 degrees

FACTORY INSTALLED OPTIONS

Nozzles: 1.5 to 4.0 GPM
 Drain check valve (up to 10' of elevation)
 Reclaimed water ID cover

USER INSTALLED OPTIONS

Drain check valve (up to 10' of elevation; P/N 142300)



Purple reclaimed rubber cover. Available as a factory-installed option on all models.



PGP-00: Overall height: 7½"
 Exposed diameter: 1¾"
 Inlet size: ¾" female NPT



PGP-04: Overall height: 7½"
 Pop-up height: 4"
 Exposed diameter: 1¾"
 Inlet size: ¾" female NPT



PGP-12: Overall height: 17"
 Pop-up height: 12"
 Exposed diameter: 1¾"
 Inlet size: ¾" female NPT



SPECIFICATIONBUILDER

hunterindustries.com/PGPULTRA

MODELS	STANDARD FEATURES	FEATURE OPTIONS	NOZZLE OPTIONS
PGP-00 = Shrub	Adjustable arc, plastic riser, 8 standard nozzles, and 4 low-angle nozzles	CV, CV-R CV = Drain check valve CV-R = Drain check valve and reclaimed water ID	1.5 to 4.0 = Factory installed nozzle number
PGP-04 = 4" pop-up			
PGP-12 = 12" pop-up			

EXAMPLES

PGP-04	4" pop-up, adjustable arc
PGP-04 - 2.5	4" pop-up, adjustable arc, and 2.5 nozzle
PGP-12 - CV-R - 4.0	12" pop-up, adjustable arc, with drain check valve, reclaimed water ID, and 4.0 nozzle

ROTORS

PGP ULTRA CHARTS



PGP Ultra Blue Standard Nozzle Performance Data (P/N 782900)

Nozzle	Pressure PSI	Radius ft.	Flow GPM	Precip in/hr	
				■	▲
1.5	25	29	1.2	0.27	0.32
	35	31	1.4	0.28	0.32
	45	31	1.5	0.30	0.35
	55	32	1.8	0.34	0.39
	65	32	1.9	0.36	0.41
2.0	25	33	1.4	0.25	0.29
	35	33	1.7	0.30	0.35
	45	34	2.0	0.33	0.38
	55	34	2.1	0.35	0.40
	65	32	2.3	0.43	0.50
2.5	25	33	1.7	0.30	0.35
	35	35	2.1	0.33	0.38
	45	35	2.5	0.39	0.45
	55	35	2.6	0.41	0.47
	65	35	2.9	0.46	0.53
3.0	25	35	2.2	0.35	0.40
	35	36	2.7	0.40	0.46
	45	38	3.0	0.40	0.46
	55	39	3.4	0.43	0.50
	65	39	3.7	0.47	0.54
4.0	25	37	3.0	0.42	0.49
	35	39	3.5	0.44	0.51
	45	40	4.0	0.48	0.56
	55	41	4.5	0.52	0.60
	65	41	4.8	0.55	0.63
5.0	25	37	3.7	0.52	0.60
	35	39	4.5	0.57	0.66
	45	42	5.0	0.55	0.63
	55	42	5.7	0.62	0.72
	65	42	6.2	0.68	0.78
6.0	25	38	4.3	0.57	0.66
	35	40	5.6	0.67	0.78
	45	43	6.0	0.62	0.72
	55	44	6.7	0.67	0.77
	65	44	7.3	0.73	0.84
8.0	25	37	6.0	0.84	0.97
	35	41	7.0	0.80	0.93
	45	44	8.0	0.80	0.92
	55	46	9.0	0.82	0.95
	65	46	9.8	0.89	1.03



PGP Ultra Low Angle Nozzle Performance Data (P/N 782900)

Nozzle	Pressure PSI	Radius ft.	Flow GPM	Precip in/hr	
				■	▲
2.0 LA	30	25	1.6	0.49	0.57
	40	27	1.9	0.50	0.58
	50	28	2.1	0.52	0.60
	60	30	2.3	0.49	0.57
	30	27	2.1	0.55	0.64
2.5 LA	40	30	2.5	0.53	0.62
	50	33	2.8	0.49	0.57
	60	35	3.0	0.47	0.54
	30	29	2.8	0.64	0.74
	40	32	3.1	0.58	0.67
3.5 LA	50	35	3.5	0.55	0.64
	60	37	3.8	0.53	0.62
	30	29	3.4	0.78	0.90
4.5 LA	40	32	3.9	0.73	0.85
	50	35	4.4	0.69	0.80
	60	37	4.7	0.66	0.76



PGP Ultra High Flow Standard Nozzle Performance Data (P/N 444800)

Nozzle	Pressure PSI	Radius ft.	Flow GPM	Precip in/hr	
				■	▲
10	40	42	8.4	0.92	1.0
	50	43	9.5	0.99	1.1
	60	45	10.5	1.00	1.1
	70	47	11.4	0.99	1.1
	40	43	10.9	1.13	1.3
13	50	44	12.3	1.22	1.4
	60	45	13.6	1.29	1.4
	70	47	14.8	1.29	1.4
	30	31	4.2	0.84	0.9
	40	35	5.0	0.79	0.9
6.0 LA	50	37	5.8	0.82	0.9
	60	39	6.3	0.80	0.9
	40	37	6.7	0.94	1.0
8.0 LA	50	39	7.7	0.97	1.1
	60	41	8.5	0.97	1.1
	70	41	9.2	1.05	1.2



PGP Ultra 18 Short Radius Nozzle Performance Data (P/N 466100)

Nozzle	Pressure PSI	Radius ft.	Flow GPM	Precip in/hr	
				■	▲
.50 SR	30	17	0.36	0.24	0.28
	40	17	0.43	0.29	0.33
	50	18	0.50	0.30	0.34
1.0 SR	60	19	0.57	0.30	0.35
	30	17	0.78	0.52	0.60
	40	17	0.90	0.60	0.69
1.5 SR	50	18	1.0	0.59	0.69
	60	19	1.1	0.59	0.68
	30	17	1.4	0.93	1.08
2.0 SR	40	17	1.7	1.13	1.31
	50	18	2.0	1.19	1.37
	60	19	2.2	1.17	1.35

PGP Ultra 25 Short Radius Nozzle Performance Data (P/N 466100)

Nozzle	Pressure PSI	Radius ft.	Flow GPM	Precip in/hr	
				■	▲
.75 SR	30	23	0.58	0.21	0.2
	40	24	0.68	0.23	0.2
	50	25	0.75	0.23	0.2
	60	26	0.83	0.24	0.2
1.5 SR	30	23	1.1	0.40	0.4
	40	24	1.3	0.43	0.5
	50	25	1.5	0.46	0.5
	60	26	1.6	0.46	0.5
3.0 SR	30	23	2.5	0.91	1.0
	40	24	2.7	0.90	1.0
	50	25	3.0	0.92	1.0
	60	26	3.1	0.88	1.0

Note: All precipitation rates calculated for 180 degree operation. For the precipitation rate for a 360 degree sprinkler, divide by 2. Optimum nozzle performance shown in bold.

**NEW NOZZLE SCREW.
ADJUST THE WAY YOU WANT TO.**



Square top nozzle makes installation easy



I-20

APPLICATION
Residential/Commercial

RADIUS
17' to 46'

FLOW RATE
0.36 to 14.8 GPM

THE I-20 IS THE ROTOR THAT'S GOT ALL THE FEATURES YOU NEED.

FEATURES

- Models: Shrub, 4", 6", 12"
- Models (stainless riser): 4", 6"
- Arc setting: 50 to 360 degrees
- Nozzle choices: 22
- Nozzle racks: 1.5 to 8.0 blue, 2.0 LA to 4.5 LA gray, 0.50 to 3.0 black, 6.0 to 13.0 green
- Factory installed rubber cover
- Through-the-top arc adjustment
- Quick check arc mechanism
- Water lubricated gear-drive
- Warranty period: 5 years

ADVANCED FEATURES

- Automatic arc return
- Non-strippable drive
- Part- and full-circle in one model
- Headed and slotted set screw
- FloStop® control
- = Detailed descriptions on pages 17 and 18
- Reclaimed water ID (optional)
- Stainless steel riser (optional)
- Drain check valve (up to 10' of elevation)
- Low angle nozzle choices

OPERATING SPECIFICATIONS

Radius: 17' to 46'
 Flow Rate: 0.36 to 14.8 GPM
 Recommended pressure range: 30 to 70 PSI
 Operating pressure range: 20 to 100 PSI
 Precipitation rates: 0.4 in/hr approx.
 Nozzle trajectory: Std = 25 degrees, Low angle = 13 degrees

FACTORY INSTALLED OPTIONS

Nozzles: 1.5 to 4.0
 Reclaimed water ID cover



I-20-00: Overall height: 7¾"
 Exposed diameter: 1¾"
 Inlet size: ¾" female NPT



I-20-04: Overall height: 7½"
 Pop-up height: 4"
 Exposed diameter: 1¾"
 Inlet size: ¾" female NPT



I-20-06: Overall height: 9½"
 Pop-up height: 6"
 Exposed diameter: 1¾"
 Inlet size: ¾" female NPT



I-20-12: Overall height: 17"
 Pop-up height: 12"
 Exposed diameter: 1¾"
 Inlet size: ¾" female NPT



SPECIFICATIONBUILDER

hunterindustries.com/I20

MODELS	STANDARD FEATURES	FEATURE OPTIONS	NOZZLE OPTIONS
I-20-00 = Shrub	Adjustable arc, plastic riser, check valve, 8 standard nozzles, and 4 low-angle nozzles	R	1.5 to 4.0 = Factory installed nozzle number
I-20-04 = 4" pop-up		NCV, R	
I-20-06 = 6" pop-up		R	
I-20-12 = 12" pop-up		R	

NCV = Without check valve
 R = Reclaimed water ID

MODELS	STANDARD FEATURES	FEATURE OPTIONS	NOZZLE OPTIONS
I-20-04-SS = 4" pop-up	Adjustable arc, stainless steel riser, check valve, 8 standard nozzles, and 4 low-angle nozzles	NCV, R	1.5 to 4.0 = Factory installed nozzle number
I-20-06-SS = 6" pop-up		R	

NCV = Without check valve
 R = Reclaimed water ID

EXAMPLES

I-20-04	4" pop-up, adjustable arc
I-20-12 - NCV - R - 4.0	12" pop-up, adjustable arc, without check valve, with reclaimed water ID, and 4.0 nozzle
I-20-06-SS - R - 3.0	6" pop-up, adjustable arc, stainless steel, reclaimed water ID, and 3.0 nozzle



Purple reclaimed rubber cover. Available as a factory-installed option on all models.

ROTORS

I-20 CHARTS



I-20 Blue Standard Nozzle Performance Data (P/N 782900)

Nozzle	Pressure PSI	Radius ft.	Flow GPM	Precip in/hr	
				■	▲
1.5	25	29	1.2	0.27	0.32
	35	31	1.4	0.28	0.32
	45	31	1.5	0.30	0.35
	55	32	1.8	0.34	0.39
	65	32	1.9	0.36	0.41
2.0	25	33	1.4	0.25	0.29
	35	33	1.7	0.30	0.35
	45	34	2.0	0.33	0.38
	55	34	2.1	0.35	0.40
	65	32	2.3	0.43	0.50
2.5	25	33	1.7	0.30	0.35
	35	35	2.1	0.33	0.38
	45	35	2.5	0.39	0.45
	55	35	2.6	0.41	0.47
	65	35	2.9	0.46	0.53
3.0	25	35	2.2	0.35	0.40
	35	36	2.7	0.40	0.46
	45	38	3.0	0.40	0.46
	55	39	3.4	0.43	0.50
	65	39	3.7	0.47	0.54
4.0	25	37	3.0	0.42	0.49
	35	39	3.5	0.44	0.51
	45	40	4.0	0.48	0.56
	55	41	4.5	0.52	0.60
	65	41	4.8	0.55	0.63
5.0	25	37	3.7	0.52	0.60
	35	39	4.5	0.57	0.66
	45	42	5.0	0.55	0.63
	55	42	5.7	0.62	0.72
	65	42	6.2	0.68	0.78
6.0	25	38	4.3	0.57	0.66
	35	40	5.6	0.67	0.78
	45	43	6.0	0.62	0.72
	55	44	6.7	0.67	0.77
	65	44	7.3	0.73	0.84
8.0	25	37	6.0	0.84	0.97
	35	41	7.0	0.80	0.93
	45	44	8.0	0.80	0.92
	55	46	9.0	0.82	0.95
	65	46	9.8	0.89	1.03



I-20 Low Angle Nozzle Performance Data (P/N 782900)

Nozzle	Pressure PSI	Radius ft.	Flow GPM	Precip in/hr	
				■	▲
2.0 LA	30	25	1.6	0.49	0.57
	40	27	1.9	0.50	0.58
	50	28	2.1	0.52	0.60
	60	30	2.3	0.49	0.57
2.5 LA	30	27	2.1	0.55	0.64
	40	30	2.5	0.53	0.62
	50	33	2.8	0.49	0.57
3.5 LA	30	29	2.8	0.64	0.74
	40	32	3.1	0.58	0.67
	50	35	3.5	0.55	0.64
4.5 LA	30	29	3.4	0.78	0.90
	40	32	3.9	0.73	0.85
	50	35	4.4	0.69	0.80
60	37	4.7	0.66	0.76	



I-20 High Flow Nozzles Performance Data (P/N 444800)

Nozzle	Pressure PSI	Radius ft.	Flow GPM	Precip in/hr	
				■	▲
10	40	42	8.4	0.92	1.06
	50	43	9.5	0.99	1.14
	60	45	10.5	1.00	1.15
	70	47	11.4	0.99	1.15
13	40	43	10.9	1.13	1.31
	50	44	12.3	1.22	1.41
	60	45	13.6	1.29	1.49
	70	47	14.8	1.29	1.49
6.0 LA	30	31	4.2	0.84	0.97
	40	35	5.0	0.79	0.91
	50	37	5.8	0.82	0.94
8.0 LA	30	31	4.2	0.84	0.97
	40	35	5.0	0.79	0.91
	50	37	5.8	0.82	0.94
60	39	6.3	0.80	0.92	
6.0 LA	40	37	6.7	0.94	1.09
	50	39	7.7	0.97	1.13
	60	41	8.5	0.97	1.12
70	41	9.2	1.05	1.22	



I-20 18' Short Radius Nozzle Performance Data (P/N 466100)

Nozzle	Pressure PSI	Radius ft.	Flow GPM	Precip in/hr	
				■	▲
.50 SR	30	17	0.36	0.24	0.28
	40	17	0.43	0.29	0.33
	50	18	0.50	0.30	0.34
	60	19	0.57	0.30	0.35
1.0 SR	30	17	0.78	0.52	0.60
	40	17	0.90	0.60	0.69
	50	18	1.0	0.59	0.69
	60	19	1.1	0.59	0.68
2.0 SR	30	17	1.4	0.93	1.08
	40	17	1.7	1.13	1.31
	50	18	2.0	1.19	1.37
	60	19	2.2	1.17	1.35

I-20 25' Short Radius Nozzle Performance Data (P/N 466100)

Nozzle	Pressure PSI	Radius ft.	Flow GPM	Precip in/hr	
				■	▲
.75 SR	30	23	0.58	0.21	0.24
	40	24	0.68	0.23	0.26
	50	25	0.75	0.23	0.27
	60	26	0.83	0.24	0.27
1.5 SR	30	23	1.1	0.40	0.46
	40	24	1.3	0.43	0.50
	50	25	1.5	0.46	0.53
	60	26	1.6	0.46	0.53
3.0 SR	30	23	2.5	0.91	1.05
	40	24	2.7	0.90	1.04
	50	25	3.0	0.92	1.07
	60	26	3.1	0.88	1.02

Note: All precipitation rates calculated for 180 degree operation. For the precipitation rate for a 360 degree sprinkler, divide by 2. Optimum nozzle performance shown in bold.

FLOSTOP™ CONTROL

FloStop closes the flow of water from individual sprinkler heads while the system is running. This is ideal for changing nozzles or turning off specific heads during maintenance and construction.



NEW NOZZLE SCREW. ADJUST THE WAY YOU WANT TO.



Square top nozzle makes installation easy



I-25

APPLICATION
Commercial/Municipal

RADIUS
37' to 71'

FLOW RATE
3.8 to 31.5 GPM

THIS RUGGED ROTOR CAN STAND UP TO ANY COMMERCIAL JOB.

FEATURES

- Models: 4", 6"
- Arc setting: 50 to 360 degrees
- Nozzle choices: 12
- Nozzle range: #4 to #28
- Factory installed rubber cover
- Through-the-top arc adjustment
- Quick check arc mechanism
- Water lubricated gear-drive
- Warranty period: 5 years

ADVANCED FEATURES

- Automatic arc return
 - Non-strippable drive
 - Part- and full-circle in one model
 - Color coded nozzles
 - Reclaimed water ID (optional)
 - Stainless steel riser (optional)
 - Drain check valve (up to 10' of elevation)
- = Detailed descriptions on pages 17 and 18

OPERATING SPECIFICATIONS

Radius: 37' to 71'
 Flow rate: 3.8 to 31.5 GPM
 Recommended pressure range: 40 to 100 PSI
 Operating pressure range: 40 to 100 PSI
 Precipitation rates: 0.4 in/hr approx.
 Nozzle trajectory: 25 degrees

FACTORY INSTALLED OPTIONS

Nozzles: #4 to #28
 Reclaimed water ID cover
 High speed rotation model (stainless steel only)



Purple reclaimed rubber cover. Available as a factory-installed option on all models.



I-25-04: Overall height: 7 7/8"
 Pop-up height: 4"
 Exposed diameter: 1 1/4"
 Inlet size: 1" female NPT



I-25-06: Overall height: 10 1/4"
 Pop-up height: 6"
 Exposed diameter: 1 1/4"
 Inlet size: 1" female NPT



SPECIFICATIONBUILDER

hunterindustries.com/I25

MODELS	STANDARD FEATURES	FEATURE OPTIONS	NOZZLE OPTIONS
I-25-04 = 4" pop-up I-25-06 = 6" pop-up	Adjustable arc, plastic riser, check valve, and 5 nozzles	R, B	#4 to #28 = Factory installed nozzle number
I-25-04-SS = 4" pop-up I-25-06-SS = 6" pop-up	Adjustable arc, stainless steel riser, check valve, and 5 nozzles	R, HS, HS-R, B	#4 to #28 = Factory installed nozzle number

EXAMPLES

I-25-04	4" pop-up, adjustable arc
I-25-04-SS - R - 18	4" pop-up, adjustable arc, stainless steel riser, reclaimed water ID, and #18 nozzle
I-25-06-SS	6" pop-up, adjustable arc, stainless steel riser

ROTORS

I-25 CHARTS



I-25 Nozzle Performance Data

Nozzle	Pressure PSI	Radius ft.	Flow GPM	Precip in/hr	
				■	▲
4 Yellow	40	40	3.8	0.46	0.53
	50	41	4.3	0.49	0.57
	60	42	4.7	0.51	0.59
	70	43	5.1	0.53	0.61
5 White	40	43	4.4	0.46	0.53
	50	44	4.8	0.48	0.55
	60	45	5.3	0.50	0.58
	70	46	5.6	0.51	0.59
7 Orange*	40	45	6.6	0.63	0.72
	50	47	7.0	0.61	0.70
	60	48	7.5	0.63	0.72
	70	49	7.9	0.63	0.73
8 Lt. Brown	40	47	7.7	0.67	0.77
	50	49	8.3	0.67	0.77
	60	50	9.2	0.71	0.82
	70	51	9.9	0.73	0.85
10 Lt. Green*	50	51	10.1	0.75	0.86
	60	52	11.1	0.79	0.91
	70	53	12.1	0.83	0.96
	80	54	12.9	0.85	0.98
13 Lt. Blue	50	53	11.2	0.77	0.89
	60	54	12.3	0.81	0.94
	70	55	13.3	0.85	0.98
	80	55	14.3	0.91	1.05
15 Gray*	50	56	13.4	0.82	0.95
	60	57	14.3	0.85	0.98
	70	57	15.2	0.90	1.04
	80	58	16.4	0.94	1.08
18 Red	50	58	14.5	0.83	0.96
	60	59	15.7	0.87	1.00
	70	62	16.9	0.85	0.98
	80	63	18.2	0.88	1.02
20 Dk. Brown*	60	62	17.8	0.89	1.03
	70	63	19.2	0.93	1.08
	80	64	20.5	0.96	1.11
	90	65	21.8	0.99	1.15
	60	64	21.9	1.03	1.19
23 Dk. Green	70	65	23.6	1.08	1.24
	80	66	25.6	1.13	1.31
	90	67	27.0	1.16	1.34
	60	66	23.5	1.04	1.20
25 Dk. Blue*	70	68	25.5	1.06	1.23
	80	69	28.0	1.13	1.31
	90	70	29.5	1.16	1.34
	70	68	26.9	1.12	1.29
28 Black	80	70	28.7	1.13	1.30
	90	71	30.6	1.17	1.35
	100	71	31.5	1.20	1.39

I-25 High-Speed Nozzle Performance Data

Nozzle	Pressure PSI	Radius ft.	Flow GPM	Precip in/hr	
				■	▲
4 Yellow	40	37	3.8	0.53	0.62
	50	38	4.3	0.57	0.66
	60	38	4.7	0.63	0.72
	70	39	5.2	0.66	0.76
5 White	40	38	4.4	0.59	0.68
	50	39	4.8	0.61	0.70
	60	40	5.5	0.66	0.76
	70	41	6.0	0.69	0.79
7 Orange*	40	40	6.1	0.73	0.85
	50	41	6.9	0.79	0.91
	60	42	7.5	0.82	0.95
	70	44	8.1	0.81	0.93
8 Lt. Brown	40	42	7.2	0.79	0.91
	50	43	8.1	0.84	0.97
	60	44	8.9	0.88	1.02
	70	45	9.8	0.93	1.08
10 Lt. Green*	50	46	10.1	0.92	1.06
	60	48	11.1	0.93	1.07
	70	49	12.1	0.97	1.12
	80	50	12.9	0.99	1.15
13 Lt. Blue	50	48	11.2	0.94	1.08
	60	49	12.3	0.99	1.14
	70	51	13.3	0.98	1.14
	80	51	14.3	1.06	1.22
15 Gray*	50	49	13.4	1.07	1.24
	60	51	14.3	1.06	1.22
	70	53	15.2	1.04	1.20
	80	54	16.4	1.08	1.25
18 Red	50	50	14.5	1.12	1.29
	60	53	15.7	1.08	1.24
	70	55	16.9	1.08	1.24
	80	57	18.2	1.08	1.25
20 Dk. Brown*	60	53	17.8	1.22	1.41
	70	56	19.2	1.18	1.36
	80	58	20.5	1.17	1.35
	90	59	21.8	1.21	1.39
	60	56	21.9	1.34	1.55
23 Dk. Green	70	58	23.6	1.35	1.56
	80	60	25.6	1.37	1.58
	90	61	27.0	1.40	1.61
	60	58	23.5	1.34	1.55
25 Dk. Blue*	70	62	25.5	1.28	1.47
	80	64	28.0	1.32	1.52
	90	66	29.5	1.30	1.51
	70	60	26.9	1.44	1.66
28 Black	80	62	28.7	1.44	1.66
	90	65	30.6	1.39	1.61
	100	67	31.5	1.35	1.56

* 5 standard nozzles included with each sprinkler.
 Note: All precipitation rates calculated for 180 degree operation.
 For the precipitation rate for a 360 degree sprinkler, divide by 2.

I-25 Nozzle Part Numbers

463401	#4	Yellow	463407	#15	Gray
463402	#5	White	463408	#18	Red
463403	#7	Orange	463409	#20	Dark Brown
463404	#8	Light Brown	463410	#23	Dark Green
463405	#10	Light Green	463411	#25	Dark Blue
463406	#13	Light Blue	463412	#28	Black

Available in bags of 25 qty.

I-35

APPLICATION
Commercial/Municipal

RADIUS
47' to 71'

FLOW RATE
7.7 to 31.5 GPM

THE I-35 IS THE ONLY 1" ROTOR WITH EVERYTHING YOU NEED BUILT RIGHT IN.

FEATURES

- Model: 6"
- Arc setting: 50 to 360 degrees
- Nozzle choices: 8
- Nozzle range: #9 to #30
- Factory installed rubber cover
- Through-the-top arc adjustment
- Quick check arc mechanism
- Water lubricated gear-drive
- Warranty period: 5 years

ADVANCED FEATURES

- Automatic arc return
 - Non-strippable drive
 - Part- and full-circle in one model
 - Headed and slotted set screw
 - FloStop® control
 - Color coded nozzles
 - Reclaimed water ID (optional)
 - Stainless steel riser (optional)
 - Drain check valve (up to 10' of elevation)
- = Detailed descriptions on pages 17 and 18

OPERATING SPECIFICATIONS

Radius: 47' to 71'
 Flow Rate: 7.7 to 31.5 GPM
 Recommended pressure range: 40 to 100 PSI
 Operating pressure range: 40 to 100 PSI
 Precipitation rates: 0.4 in/hr approx.
 Nozzle trajectory: 25 degrees

FACTORY INSTALLED OPTIONS

Nozzles: #9 to #30
 Reclaimed water ID cover
 High speed rotation model (stainless steel only)



Purple reclaimed rubber cover. Available as a factory-installed option on all models.



I-35-06: Overall height: 10 $\frac{3}{8}$ "
 Pop-up height: 6"
 Exposed diameter: 1 $\frac{1}{8}$ "
 Inlet size: 1" female NPT



SPECIFICATIONBUILDER

hunterindustries.com/l35

MODEL	STANDARD FEATURES	FEATURE OPTIONS	NOZZLE OPTIONS
I-35-06 = 6" pop-up	Adjustable arc, plastic riser, check valve, and 8 nozzles	R, B	#9 to #30 = Factory installed nozzle number

MODEL	STANDARD FEATURES	FEATURE OPTIONS	NOZZLE OPTIONS
I-35-06-SS = 6" pop-up	Adjustable arc, stainless steel riser, check valve, and 8 nozzles	R, HS, HS-R, B	#9 to #30 = Factory installed nozzle number

EXAMPLES

I-35-06	6" pop-up, adjustable arc
I-35-06-SS - R - 18	6" pop-up, adjustable arc, stainless steel riser, reclaimed water ID, and #18 nozzle
I-35-06-SS	6" pop-up, adjustable arc, stainless steel riser

ROTORS

I-35 CHARTS



I-35 Nozzle Performance Data

Nozzle	Pressure PSI	Radius ft.	Flow GPM	Precip in/hr	
				■	▲
9 Lt. Brown	40	47	7.7	0.67	0.77
	50	49	8.3	0.67	0.77
	60	50	9.2	0.71	0.82
	70	50	9.9	0.73	0.85
12 Lt. Blue	50	53	11.2	0.77	0.89
	60	54	12.3	0.81	0.94
	70	55	13.3	0.85	0.98
	80	55	14.3	0.91	1.05
15 Gray	50	56	13.4	0.82	0.95
	60	57	14.3	0.85	0.98
	70	57	15.2	0.90	1.04
	80	58	16.4	0.94	1.08
18 Red	50	58	14.5	0.83	0.96
	60	59	15.7	0.87	1.00
	70	62	16.9	0.85	0.98
	80	63	18.2	0.88	1.02
21 Dk. Brown	60	62	17.8	0.89	1.03
	70	63	19.2	0.93	1.08
	80	64	20.5	0.96	1.11
	90	65	21.8	0.99	1.15
24 Dk. Green	60	64	21.9	1.03	1.19
	70	65	23.6	1.08	1.24
	80	66	25.6	1.13	1.31
	90	67	27.0	1.16	1.34
27 Dk. Blue	60	66	23.5	1.04	1.20
	70	68	25.5	1.06	1.23
	80	69	28.0	1.13	1.31
	90	70	29.5	1.16	1.34
30 Black	70	68	26.9	1.12	1.29
	80	70	28.7	1.13	1.30
	90	71	30.6	1.17	1.35
	100	71	31.5	1.20	1.39

I-35 High-Speed Nozzle Performance Data

Nozzle	Pressure PSI	Radius ft.	Flow GPM	Precip in/hr	
				■	▲
9 Lt. Brown	40	42	7.7	0.84	0.97
	50	43	8.3	0.86	1.00
	60	44	9.2	0.91	1.06
	70	45	9.9	0.94	1.09
12 Lt. Blue	50	48	11.2	0.94	1.08
	60	49	12.3	0.99	1.14
	70	51	13.3	0.98	1.14
	80	51	14.3	1.06	1.22
15 Gray	50	49	13.4	1.07	1.24
	60	51	14.3	1.06	1.22
	70	53	15.2	1.04	1.20
	80	54	16.4	1.08	1.25
18 Red	50	50	14.5	1.12	1.29
	60	53	15.7	1.08	1.24
	70	55	16.9	1.08	1.24
	80	57	18.2	1.08	1.25
21 Dk. Brown	60	53	17.8	1.22	1.41
	70	56	19.2	1.18	1.36
	80	58	20.5	1.17	1.35
	90	59	21.8	1.21	1.39
24 Dk. Green	60	56	21.9	1.34	1.55
	70	58	23.6	1.35	1.56
	80	60	25.6	1.37	1.58
	90	61	27.0	1.40	1.61
27 Dk. Blue	60	58	23.5	1.34	1.55
	70	62	25.5	1.28	1.47
	80	64	28.0	1.32	1.52
	90	66	29.5	1.30	1.51
30 Black	70	60	26.9	1.44	1.66
	80	62	28.7	1.44	1.66
	90	65	30.6	1.39	1.61
	100	67	31.5	1.35	1.56



I-35 Low Pressure Nozzle Performance Data

Nozzle	Pressure PSI	Radius ft.	Flow GPM	Precip in/hr	
				■	▲
7LP Orange	40	45	7.5	0.71	0.82
	50	45	8.5	0.81	0.93
	60	46	9.5	0.86	1.00
10LP Lt. Green	40	50	10.1	0.78	0.90
	50	51	11.5	0.85	0.98
	60	53	12.8	0.88	1.01

I-35 Low Pressure Nozzle Performance Data

Nozzle	Pressure PSI	Radius ft.	Flow GPM	Precip in/hr	
				■	▲
13LP Lt. Blue	40	53	12.4	0.85	0.98
	50	54	14.0	0.92	1.07
	60	55	15.6	0.99	1.15
15LP Gray	40	55	14.7	0.94	1.08
	50	58	17.1	0.98	1.13
	60	60	18.5	0.99	1.14

Note: All precipitation rates calculated for 180 degree operation. For the precipitation rate for a 360 degree sprinkler, divide by 2.

Low Pressure Nozzle Part Numbers

460013	#7LP
460014	#10LP
460015	#13LP
460016	#15LP

Available in bags of 25 qty.

I-40

APPLICATION
Commercial/High-End Municipal

RADIUS
45' to 76'

FLOW RATE
7.0 to 33.7 GPM

FOR SPORTS FIELDS AND PARKS, I-40 DELIVERS PROFESSIONAL RESULTS.

FEATURES

- Models (stainless riser): 4", 6"
- Arc setting: 50 to 360 degrees
- Nozzle choices: 6
- Nozzle ranges: #40 to #45, #15 to #28
- Factory installed rubber cover
- Through-the-top arc adjustment
- Quick check arc mechanism
- Water lubricated gear-drive
- Warranty period: 5 years

ADVANCED FEATURES

- Automatic arc return
 - Non-strippable drive
 - Part- and full-circle in one model
 - Opposing nozzle 360° model
 - Reclaimed water ID (optional)
 - Stainless steel riser
 - Drain check valve (up to 15' of elevation)
- = Detailed descriptions on pages 17 and 18

OPERATING SPECIFICATIONS

Radius: 45' to 76'
 Flow rate: 7.0 to 33.7 GPM
 Recommended pressure range: 40 to 100 PSI
 Operating pressure range: 40 to 100 PSI
 Precipitation rates: 0.4 in/hr approx.
 Nozzle trajectory: 25 degrees

FACTORY INSTALLED OPTIONS

Nozzles: #40 to #45, #15 to #28
 Reclaimed water ID cover
 High speed rotation model

USER INSTALLED OPTIONS

Turf cup kit (P/N 460000)



Purple reclaimed rubber cover. Available as a factory-installed option on all models.



I-40-04: Overall height: 7 1/8"
 Pop-up height: 4"
 Exposed diameter: 2"
 Inlet size: 1" female NPT



I-40-06: Overall height: 10 1/4"
 Pop-up height: 6"
 Exposed diameter: 2"
 Inlet size: 1" female NPT



SPECIFICATIONBUILDER

hunterindustries.com/I40

MODELS	STANDARD FEATURES	FEATURE OPTIONS	NOZZLE OPTIONS
I-40-04-SS = 4" pop-up	Adjustable arc, stainless steel riser, check valve, and 6 nozzles	ON, ON-R, HS, HS-R, R, B	#40 to #45 = Factory installed nozzle number #15 to #28 = Factory installed nozzle number
I-40-06-SS = 6" pop-up			

EXAMPLES

I-40-04-SS	4" pop-up, adjustable arc
I-40-04-SS - ON-R - 44	4" pop-up, adjustable arc, full circle opposing nozzles, reclaimed water ID, and #44 nozzle
I-40-06-SS - 43	6" pop-up, adjustable arc, and #43 nozzle

ROTORS

I-40 CHARTS

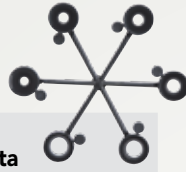

I-40 Nozzle Performance Data

Nozzle	Pressure PSI	Radius ft.	Flow GPM	Precip in/hr	
				■	▲
40	40	45	7.0	0.67	0.77
	50	46	8.0	0.73	0.84
	60	46	8.5	0.77	0.89
41	50	50	10.2	0.79	0.91
	60	51	11.1	0.82	0.95
	70	52	12.1	0.86	0.99
42	80	53	13.0	0.89	1.03
	50	51	11.0	0.81	0.94
	60	53	12.3	0.84	0.97
43	70	55	13.1	0.83	0.96
	80	56	13.9	0.85	0.99
	50	56	13.5	0.83	0.96
44	60	57	15.1	0.89	1.03
	70	59	16.1	0.89	1.03
	80	61	17.5	0.91	1.05
45	60	63	20.0	0.97	1.12
	70	65	21.8	0.99	1.15
	80	66	23.4	1.03	1.19
	90	67	24.9	1.07	1.23
	60	66	22.7	1.00	1.16
	70	68	24.7	1.03	1.19
	80	69	26.4	1.07	1.23
	90	70	28.2	1.11	1.28

I-40 High Speed Nozzle Performance Data

Nozzle	Pressure PSI	Radius ft.	Flow GPM	Precip in/hr	
				■	▲
40	40	41	7.0	0.80	0.93
	50	42	8.0	0.87	1.01
	60	42	8.5	0.93	1.07
41	50	44	10.2	1.01	1.17
	60	44	11.1	1.10	1.27
	70	45	12.1	1.15	1.33
42	80	46	13.0	1.18	1.37
	50	46	11.0	1.00	1.16
	60	47	12.3	1.07	1.24
43	70	49	13.1	1.05	1.21
	80	50	13.9	1.07	1.24
	50	51	13.5	1.00	1.15
44	60	52	15.1	1.07	1.24
	70	52	16.1	1.15	1.32
	80	53	17.5	1.20	1.38
45	60	58	20.0	1.14	1.32
	70	58	21.8	1.25	1.44
	80	60	23.4	1.25	1.44
	90	60	24.9	1.33	1.54
	60	60	22.7	1.21	1.40
	70	62	24.7	1.24	1.43
	80	64	26.4	1.24	1.43
	90	65	28.2	1.28	1.48

I-40 Dual Opposing Nozzle Performance Data

Nozzle	Pressure PSI	Radius ft.	Flow GPM	Precip in/hr	
				■	▲
15 Gray	50	52	13.0	0.46	0.53
	60	54	13.2	0.44	0.50
	70	56	14.4	0.44	0.51
	80	57	15.5	0.46	0.53
18 Red	50	58	13.7	0.39	0.45
	60	59	15.2	0.42	0.49
	70	60	16.6	0.44	0.51
	80	62	17.8	0.45	0.51
20 Dk. Brown	60	63	19.1	0.46	0.53
	70	64	20.9	0.49	0.57
	80	66	22.3	0.49	0.57
	90	66	23.9	0.53	0.61
23 Dk. Green	60	65	20.4	0.46	0.54
	70	66	22.3	0.49	0.57
	80	67	24.0	0.51	0.59
	90	68	25.6	0.53	0.62
25 Dk. Blue*	60	66	22.0	0.49	0.56
	70	68	24.0	0.50	0.58
	80	69	25.9	0.52	0.60
	90	70	27.2	0.53	0.62
28 Black	70	70	28.9	0.57	0.66
	80	72	30.9	0.57	0.66
	90	74	32.9	0.58	0.67
	100	76	33.7	0.56	0.65

* Factory-installed nozzle

Note: All precipitation rates are calculated for 180 degree operation. For the precipitation rate for a 360 degree sprinkler, divide by 2. Precipitation rates for the ON model are calculated at 360 degrees.

OPPOSING NOZZLE 360° MODEL



I-60

APPLICATION
Low Pressure Commercial/Municipal

RADIUS
50' to 67'

FLOW RATE
6.5 to 20.8 GPM

THE I-60 IS IDEAL FOR LARGE-AREA TURF SITES WITH LOWER PRESSURES.

FEATURES

- Model (stainless riser): 3"
- Arc setting:
ADS: 40–360 degrees
36S: full-circle only
- Nozzle choices: 6
- Nozzle range: #7 to #20
- Standard factory installed nozzle: #13
- Factory installed rubber cover
- Through-the-top arc adjustment
- Quick check arc mechanism
- Water lubricated gear-drive
- Warranty period: 5 years

ADVANCED FEATURES

- Color coded nozzles
- Reclaimed water ID (optional)
- Stainless steel riser
- Drain check valve (up to 10' of elevation)
- = Detailed descriptions on pages 17 and 18

OPERATING SPECIFICATIONS

Radius: 50' to 67'
 Flow rate: 6.5 to 20.8 GPM
 Recommended pressure range: 40 to 60 PSI
 Operating pressure range: 20 to 100 PSI
 Precipitation rates: 0.4 in/hr approx.
 Nozzle trajectory: 25 degrees

FACTORY INSTALLED OPTIONS

Nozzles: #7 to #20
 Reclaimed water ID cover



I-60: Overall height: ADS/36S: 8³/₈"
 Pop-up height: 3"
 Exposed diameter: 1³/₄"
 Inlet size: 1" female NPT



SPECIFICATIONBUILDER

hunterindustries.com/160

MODEL	STANDARD FEATURES	FEATURE OPTIONS	NOZZLE OPTIONS
I-60 = 3" pop-up	Stainless steel riser, check valve, and 6 nozzles	ADS, ARS, 36S, 3RS, B	#7 to #20 = Factory installed nozzle number

EXAMPLES

I-60 - ADS	3" pop-up, adjustable arc
I-60 - 36S - 10	3" pop-up, full circle, and #10 nozzle
I-60 - 3RS - 7	3" pop-up, full circle, reclaimed water ID and #7 nozzle

ROTORS

I-60 CHARTS



I-60 ADS Nozzle Performance Data

Nozzle	Pressure PSI	Radius ft.	Flow GPM	Precip in/hr	
				■	▲
7 Orange	40	50	6.5	0.50	0.58
	50	52	7.1	0.51	0.58
	60	54	7.7	0.51	0.59
10 Lt. Green	40	53	8.5	0.58	0.67
	50	56	9.5	0.58	0.67
	60	58	10.2	0.58	0.67
13 Lt. Blue*	40	56	10.5	0.64	0.74
	50	58	12.1	0.69	0.80
	60	60	13.0	0.70	0.80
15 Gray	40	58	12.5	0.72	0.83
	50	60	13.9	0.74	0.86
	60	62	15.1	0.76	0.87
18 Red	40	59	15.6	0.86	1.00
	50	62	17.5	0.88	1.01
	60	65	18.6	0.85	0.98
20 Dk. Brown	40	62	17.5	0.88	1.01
	50	64	19.1	0.90	1.04
	60	66	20.4	0.90	1.04

I-60 36S Nozzle Performance Data

Nozzle	Pressure PSI	Radius ft.	Flow GPM	Precip in/hr	
				■	▲
7 Orange	40	51	6.5	0.24	0.28
	50	54	7.5	0.25	0.29
	60	56	8.0	0.25	0.28
10 Lt. Green	40	53	8.5	0.29	0.34
	50	56	9.5	0.29	0.34
	60	58	10.2	0.29	0.34
13 Lt. Blue*	40	56	10.5	0.32	0.37
	50	58	12.4	0.35	0.41
	60	60	13.0	0.35	0.40
15 Gray	40	58	12.5	0.36	0.41
	50	60	14.0	0.37	0.43
	60	62	15.1	0.38	0.44
18 Red	40	59	15.6	0.43	0.50
	50	62	17.7	0.44	0.51
	60	65	18.9	0.43	0.50
20 Dk. Brown	40	62	17.5	0.44	0.51
	50	64	19.1	0.45	0.52
	60	67	20.8	0.45	0.51

* Factory-installed nozzle

Note: All precipitation rates calculated for 180-degree operation. For the precipitation rate for a 360-degree sprinkler, divide by 2. Precipitation rates for the 36S model are calculated at 360 degrees.



For additional options on projects where low operating pressure is a concern, please see the new I-35 Low Pressure Nozzles on page 30.

I-90

APPLICATION
Large Radius Commercial/Municipal

RADIUS
63' to 101'

FLOW RATE
22 to 83 GPM

HUNTER'S LONGEST DISTANCE ROTOR IS PERFECT FOR PARKS AND SPORTS FIELDS.

FEATURES

- Model: 3"
- Arc setting: 40 to 360 degrees
- Nozzle choices: 8
- Nozzle range: #25 to #73
- Through-the-top arc adjustment
- Quick check arc mechanism
- Water lubricated gear-drive
- Standard factory installed nozzle: #53
- Factory installed rubber logo cap
- Warranty period: 5 years

ADVANCED FEATURES

- Opposing nozzle 360° model
- Color coded nozzles
- Reclaimed water ID (optional)
- Drain check valve (up to 9' of elevation)
- = Detailed descriptions on pages 17 and 18

OPERATING SPECIFICATIONS

Radius: 63' to 101'
 Flow rate: 22 to 83 GPM
 Recommended pressure range: 60 to 110 PSI
 Operating pressure range: 50 to 120 PSI
 Precipitation rates: 0.75 in/hr approx.
 Nozzle trajectory: 22.5 degrees

FACTORY INSTALLED OPTIONS

Nozzles: #25 to #73
 Reclaimed water ID cover

USER INSTALLED OPTIONS

Rubber Cover Kit I90-ADV (P/N 234200)
 Rubber Cover Kit I90-36V (P/N 234201)
 Turf Cup Kit (P/N 467955)



I-90: Overall height: ADV/36V: 11"
 Pop-up height: 3"
 Exposed diameter: 3½"
 Inlet size: 1½" female NPT



Turf cup kit (P/N 467955)



Rubber cover kits
 (P/N 234200, P/N 234201)



SPECIFICATIONBUILDER

hunterindustries.com/I90

MODEL	STANDARD FEATURES	FEATURE OPTIONS	NOZZLE OPTIONS
I-90 = 3" pop-up	Plastic riser, check valve, and 8 nozzles	ADV, ARV, 36V, 3RV, B ADV = Adjustable arc ARV = Adjustable arc and reclaimed water ID 36V = Full circle, opposing nozzles 3RV = Full circle, opposing nozzles and reclaimed water ID B = BSP inlet threads	#25 to #73 = Factory installed nozzle number

EXAMPLES









I-90 - ADV	3" pop-up, adjustable arc
I-90 - 36V - 43	3" pop-up, full circle, opposing nozzles, and #43 nozzle
I-90 - 3RV - 63	3" pop-up, full circle, opposing nozzles, reclaimed water ID, and #63 nozzle

ROTORS









I-90 CHARTS



I-90-ADV Nozzle Performance Data

Nozzle	Pressure PSI	Radius ft.	Flow GPM	Precip in/hr	
				■	▲
25  Lt. Blue NEW	60	63	22.0	1.07	1.23
	70	64	24.9	1.17	1.35
	80	65	27.5	1.25	1.45
	90	67	28.8	1.24	1.43
	100	68	30.6	1.27	1.47
33  Gray	60	67	30.7	1.32	1.52
	70	67	33.1	1.42	1.64
	80	68	35.5	1.48	1.71
	90	69	37.7	1.52	1.76
38  Red	60	69	34.0	1.37	1.59
	70	70	36.9	1.45	1.67
	80	72	39.8	1.48	1.71
	90	73	42.3	1.53	1.76
43  Dk. Brown	60	70	38.7	1.52	1.76
	70	71	42.0	1.60	1.85
	80	72	44.5	1.65	1.91
	90	73	47.6	1.72	1.99
48  Dk. Green	60	70	38.7	1.52	1.76
	70	75	47.0	1.61	1.86
	80	77	50.2	1.63	1.88
	90	79	53.3	1.64	1.90
53  Dk. Blue*	60	79	48.5	1.50	1.73
	80	81	53.4	1.57	1.81
	90	85	57.0	1.52	1.75
	100	86	59.5	1.55	1.79
63  Black	70	84	60.9	1.66	1.92
	80	86	63.8	1.66	1.92
	90	88	66.5	1.65	1.91
	100	90	69.8	1.66	1.92
73  Orange NEW	80	90	66.9	1.59	1.84
	90	92	69.7	1.59	1.83
	100	95	72.8	1.55	1.79
	110	98	76.2	1.53	1.76

I-90-36V Nozzle Performance Data

Nozzle	Pressure PSI	Radius ft.	Flow GPM	Precip in/hr	
				■	▲
25  Lt. Blue NEW	60	69	25.5	0.52	0.60
	70	71	27.8	0.53	0.61
	80	73	30.2	0.55	0.63
	90	75	31.7	0.54	0.63
	100	77	33.9	0.55	0.64
33  Gray	60	71	29.8	0.57	0.66
	70	74	32.2	0.57	0.65
	80	76	34.4	0.57	0.66
	90	78	36.8	0.58	0.67
38  Red	60	74	33.3	0.59	0.68
	70	77	36.1	0.59	0.68
	80	79	38.4	0.59	0.68
	90	80	40.9	0.62	0.71
43  Dk. Brown	60	77	38.1	0.62	0.71
	70	79	40.9	0.63	0.73
	80	82	43.9	0.63	0.73
	90	83	46.5	0.65	0.75
48  Dk. Green	60	77	38.1	0.62	0.71
	70	82	46.3	0.66	0.77
	80	86	49.6	0.65	0.75
	90	89	52.5	0.64	0.74
53  Dk. Blue*	60	79	48.5	1.50	1.73
	80	81	53.4	1.57	1.81
	90	85	57.0	1.52	1.75
	100	86	59.5	1.55	1.79
63  Black	70	84	60.9	1.66	1.92
	80	86	63.2	0.72	0.83
	90	94	65.9	0.72	0.83
	100	96	69.4	0.72	0.84
73  Orange NEW	80	95	72.1	0.77	0.89
	90	97	75.9	0.78	0.90
	100	99	79.5	0.78	0.90
	110	101	83.0	0.78	0.90

* Factory-installed nozzle

** Preliminary performance data

Note: All ADV precipitation rates are calculated for 180-degree operation. For 360-degree rates, divide by 2. Precipitation rates for the 36V model are calculated at 360 degrees.

ST SYSTEM ROTORS

APPLICATION

Synthetic Sports Turf Fields

RADIUS

103' to 160'

FLOW RATES

74.5 to 286.4 GPM

HUNTER'S LONG RANGE ROTORS DEDICATED TO SYNTHETIC TURF SPORTS FIELD IRRIGATION.

FEATURES

- Models:
 - 3" jar top (ST-90)
 - 3" top service (STG-900)
 - 5" top service (ST-1600B)
 - Riser mount (ST-1600BR)
- Nozzle choices:
 - 1 (ST-90, STG-900)
 - 5 (ST-1600B, ST-1600BR)
- Nozzle ranges:
 - #73 (ST-90, STG-900)
 - #16 to 24 (ST-1600B, ST-1600BR)
- Standard installed nozzle:
 - #73 (ST-90, STG-900)
 - #20 (ST-1600B, ST-1600BR)
- Arc adjustment:
 - Through-the-top (ST-90, STG-900)
 - Movable stops (ST-1600B, ST-1600BR)
- Arc setting: 40 to 360 degrees (all models)
- Quick check arc mechanism (all models)
- Gear-drive:
 - Water lubricated (ST-90, STG-900)
 - Isolated grease lubrication (ST-1600B, ST-1600BR)
- Ratcheting nozzle turret (ST-1600B, ST-1600BR)
- Factory installed rubber logo cap (all models)
- Nozzle trajectory: 22.5 degrees (all models)
- 5-year component part warranty (all models)

OPERATING SPECIFICATIONS

Radius: 103' to 115' (ST-90, STG-900);
107' to 160' (ST-1600B, ST-1600BR)

Flow rate: 74.5 to 79.6 GPM (ST-90, STG-900);
96.2 to 286.4 GPM (ST-1600B, ST-1600BR)

Operating pressure range: 100 to 120 PSI
(ST-90, STG-900);

60 to 120 PSI (ST-1600B, ST-1600BR)

Precipitation rate: 1.25 in/hr approx.
(ST-90, STG-900);

2.25 in/hr approx. (ST-1600B, ST-1600BR)

USER INSTALLED OPTIONS

Rubber Cover Kit ST-90 (P/N 234200)

Rubber Cover Kit STG-900 (P/N 473900)



SPECIFICATIONBUILDER

hunterindustries.com/ST

MODELS	STANDARD FEATURES	FEATURE OPTIONS	NOZZLE OPTION
ST-90 = 3" pop-up	Jar top cap synthetic turf rotor, adjustable arc with plastic riser, NPT inlet threads	B = BSP inlet threads	#73 = Factory installed nozzle number
STG-900 = 3" pop-up	Top service synthetic turf rotor, adjustable arc with plastic riser, ACME inlet threads		
ST-1600 = 5" pop-up	Top service synthetic turf rotor, adjustable arc with stainless riser, includes 5 nozzle pack, no NPT inlet threads available	B = BSP inlet threads*	
ST-1600 = riser mount	Adjustable arc, includes 5 nozzle pack, no NPT inlet threads available	BR = BSP inlet threads, riser mount*	

* to adapt to 2" pipe use adapter PN 241400

EXAMPLES

ST-90 - 73	3" pop-up, jar top cap, adjustable arc, plastic riser, NPT inlet threads, and #73 nozzle
STG-900 - 73	3" pop-up, top service, adjustable arc, plastic riser, ACME inlet threads, and #73 nozzle
ST-1600 - B	5" pop-up, top service, adjustable arc, stainless riser, BSP inlet threads, and 5 nozzle pack
ST-1600 - B - R	riser mount, adjustable arc, BSP inlet threads, and 5 nozzle pack

ST SYSTEM ACCESSORIES

A UNIQUE PACKAGE OF ROTORS AND ACCESSORIES PERFECTLY SUITED FOR COOLING AND CLEANING SYNTHETIC TURF SPORTS FIELDS.

PERFORMANCE DATA

ST-90/STG-900 Performance Data

Nozzle	Pressure PSI	Radius ft.	Flow GPM	Precip in/hr	
				■	▲
73	100	103	74.5	1.35	1.56
	110	109	77.0	1.25	1.44
	120	115	79.6	1.16	1.34

ST-1600 Nozzle Performance Data

Nozzle	Pressure PSI	Radius ft.	Flow GPM	Precip in/hr	
				■	▲
16	60	107	96.2	1.63	1.88
	75	115	107.3	1.57	1.81
	90	121	117.8	1.54	1.78
	105	128	127.3	1.50	1.73
	120	135	137.4	1.46	1.69
18	60	112	107.0	1.66	1.91
	75	121	119.4	1.56	1.80
	90	128	131.0	1.54	1.78
	105	133	141.3	1.54	1.78
20	60	115	144.0	2.10	2.43
	75	128	160.9	1.89	2.18
	90	141	176.5	1.71	1.97
	105	144	190.5	1.76	2.03
22	60	118	171.5	2.37	2.73
	75	130	191.8	2.20	2.54
	90	144	210.0	1.94	2.24
	105	154	226.9	1.84	2.12
24	60	121	202.1	2.64	3.05
	75	133	225.9	2.46	2.84
	90	148	247.6	2.19	2.52
	105	156	267.4	2.12	2.45
120	160	286.4	2.16	2.49	

Note: All precipitation rates calculated for 180 degree operation.
For precipitation rate of 360 degree sprinkler divide by 2.



ST SWING JOINTS

Multi-axis 315 PSI rated vertical alignment swing joints with seven O-ring sealed pivot points

ST2008VA - 2" for ST-90, STG-900
ST3010VA - 3" for ST-1600B



ST VAULTS

Heavy-duty tapered fiberglass and polymer-concrete construction with pre-case holes for rotor and quick coupler valve

ST173026B - for STG-900 includes 2" thick 3-piece PC cover set
Cover: 17" x 30"
Height: 26"
Base pad: 27" x 41"

ST243642B - for ST-1600 includes 3" thick 4-piece PC cover set
Cover: 24" x 36"
Height: 42"
Base pad: 44" x 50"



ST VALVE SETS

Heavy-duty control valves configured to compliment the ST Rotors and ST Vaults

STVBVFK - for STG-900 in STK-2 Kit
9.8 PSI loss at 100 GPM from swing joint inlet through to rotor

STV30K - for ST-1600B in STK-6 Kit
2.0 PSI loss at 286 GPM from swing joint inlet through to rotor

The ST Kits ►

For specification ease and to ensure the correct product is installed, the ST System is available in four kit configurations.

	STK-1: STG-900 Block System (remotely located valve)	STK-2: STG-900 VAH System (valve adjacent to head)	STK-5: ST-1600 Block System (remotely located valve)	STK-6: ST-1600 VAH System (valve adjacent to head)
ST Rotor	STG-900 -73	STG-900 -73	ST-1600B	ST-1600B
ST Vault	ST173026B	ST173026B	ST243642B	ST243642B
ST Swing Joint	ST2008VA	ST2008VA	ST3010VA	ST3010VA
ST Valve Sets	—	STVBVFK	STV30K	STV30K
ST Fitting Sets	239300 and 239800	239800	STF30K	STF30K
Rubber Cover Kit	473900	473900	—	—
Quick Coupler Valve	HQ5RC	HQ5RC	HQ5RC	HQ5RC



RESETTING THE STANDARD. Hunter sprays have been an industry benchmark for years, a lofty goal that has been reimagined over and over. From the conservation-minded MP Rotator to the multi-talented family of Pro-Sprays, Hunter's line of sprays doesn't know where to stop.

SPRAYS

COMPARISON CHART

	PS ULTRA	PRO- SPRAY®	PRS30*	PRS40†
APPLICATIONS				
Turfgrass	•	•	•	•
Turfgrass: Tall mowing height	•	•	•	•
Ground cover	•	•	•	•
Shrubs: Sprinklers on risers	•	•	•	•
Shrubs: Tall pop-up sprinklers		•	•	•
Residential	•	•	•	•
Commercial		•	•	•
High traffic areas		•	•	•
Reclaimed water		•	•	•
Field-installed check valve option	•	•	•	•
Factory-installed check valve option		•	•	•
Pressure regulation			•	•

* Formerly Institutional Spray

† Formerly MPR40

ADVANCED FEATURES

CO-MOLDED WIPER SEAL

This pressure-activated, multi-function wiper seal was designed to reduce flow-by. The zero flush seal operates at low pressures and allows more sprinkler heads on the same zone. The wiper seal's design protects the riser when operating, and keeps debris out of the seal when retracted, reducing riser stick-ups.



BODY CAP WON'T LEAK UNDER HIGH PRESSURE

The Pro-Spray line incorporates a heavy-duty ribbed body and durable cap engineered to withstand the harshest environments, including the rigors of foot traffic and the abuses of heavy machinery. In addition, a multi-thread buttress design provides superior strength in cap-to-body gripping capacity helping the head to withstand high inlet surge pressures.



Competitor

Pro-Spray

PRO-SPRAY CHECK VALVE

Optional check valves eliminate leaks and puddles at the lower heads, protecting landscapes from damage and erosion while reducing water waste. Choose from the convenience of factory-installed check valves or the flexibility of field installation.



HEAVY-DUTY SPRING

The strongest retraction spring for positive retraction under any conditions.



PRESSURE REGULATED TO 30/40 PSI

Hunter's pressure regulated pop-up sprays are calibrated for the needs of any installation. The PRS30 with the brown cap optimizes performance of your traditional sprays at 30 PSI. The gray-capped PRS40 is designed for the efficient MP Rotator and is the only 40 PSI regulated pop-up on the market today.



ALL SPRAY BODIES AND NOZZLES are put to the test at Hunter's state-of-the-art facility so they are ready to take on any obstacle in the field.

Hunter®



PS ULTRA

APPLICATION

Residential

MODELS

2", 4", 6"

PS ULTRA IS THE SLIM SPRAY WITH ALL THE FEATURES FOR ANY INSTALLATION.

FEATURES

- Application: Residential
- Models: 2", 4", 6"
- Nozzle choices: 5
- Flow rate: 0.2 to 5.6 GPM
- Nozzle choices: 10A, 12A, 15A, 17A, 5' x 30' side strip (side strip pattern available on 2" and 4" models only)
- Warranty period: 2 years

ADVANCED PS ULTRA FEATURES

- Preinstalled Pro Adjustable nozzle
- Enhanced cap for more durability, easier handling, and extended riser seal life
- 2" and 4" models can retro-fit into older style PS sprays
- Two-piece ratchet
- Male threaded riser to accept all female nozzles
- Available with flush plug (large filter screen not included)
- Extra large filter screen

ADVANCED PRO ADJUSTABLE NOZZLE FEATURES

- Crisp edges result in well defined pattern
- Easy grip top for simple adjustments
- Large water droplets that can handle light winds
- Even distribution results in beautiful pattern
- Matched precipitation rate throughout nozzles

OPERATING SPECIFICATIONS

Flow rate: 0.2 to 5.6 GPM
 Radius: 9' to 19'
 Recommended pressure range: 20 to 70 PSI
 Precipitation rates: 1.6 to 1.9 in/hr approx.

USER INSTALLED OPTIONS

Drain check valve: 4" and 6" models (up to 7' of elevation; P/N 462237)
 Large basket filter screen (replacement; P/N 162900)

FACTORY INSTALLED OPTIONS

Nozzles: 10A, 12A, 15A, 17A, 5' x 30' side strip
 Flush plug (large basket filter screen not included)



SPECIFICATIONBUILDER

hunterindustries.com/PSULTRA

MODELS	RADIUS
PSU-02 = 2" pop-up	10A = 10' adjustable nozzle 12A = 12' adjustable nozzle 15A = 15' adjustable nozzle 17A = 17' adjustable nozzle 5SS = 5' X 30' side strip (2" and 4" only)
PSU-04 = 4" pop-up	
PSU-06 = 6" pop-up	

EXAMPLES

PSU-04 - 15A	4" pop-up, with a 15' adjustable nozzle
PSU-02 - 5SS	2" pop-up, with a 5' X 30' side strip
PSU-06 - 10A	6" pop-up, with a 10' adjustable nozzle
PSU-04	4" pop-up, with flush plug Large filter screen not included

PS ULTRA CHART

PS Ultra Standard Nozzles Performance Data

Arc	Pressure PSI	10 Foot Radius Adjustable from 0° to 360° Trajectory: 15° Color Code: Red				12 Foot Radius Adjustable from 0° to 360° Trajectory: 28° Color Code: Green				15 Foot Radius Adjustable from 0° to 360° Trajectory: 28° Color Code: Black				17 Foot Radius Adjustable from 0° to 360° Trajectory: 28° Color Code: Gray			
		Radius ft.	Flow GPM	Nozzle 10A Precip in/hr		Radius ft.	Flow GPM	Nozzle 12A Precip in/hr		Radius ft.	Flow GPM	Nozzle 15A Precip in/hr		Radius ft.	Flow GPM	Nozzle 17A Precip in/hr	
45°	20	9	0.20	1.86	2.15	11	0.25	1.60	1.85	14	0.37	1.46	1.69	16	0.48	1.44	1.67
	25	10	0.22	1.71	1.97	12	0.28	1.52	1.76	15	0.42	1.44	1.66	17	0.54	1.45	1.67
	30	10	0.25	1.89	2.18	12	0.32	1.68	1.95	15	0.47	1.59	1.84	17	0.60	1.60	1.85
	35	11	0.27	1.70	1.96	13	0.34	1.56	1.80	16	0.51	1.52	1.76	18	0.65	1.55	1.79
90°	20	9	0.39	1.86	2.15	11	0.50	1.60	1.85	14	0.74	1.46	1.69	16	0.96	1.44	1.67
	25	10	0.44	1.71	1.97	12	0.57	1.52	1.76	15	0.84	1.44	1.66	17	1.09	1.45	1.67
	30	10	0.49	1.89	2.18	12	0.63	1.68	1.95	15	0.93	1.59	1.84	17	1.20	1.60	1.85
	35	11	0.53	1.70	1.96	13	0.69	1.56	1.80	16	1.01	1.52	1.76	18	1.31	1.55	1.79
120°	20	9	0.52	1.86	2.15	11	0.67	1.60	1.85	14	0.99	1.46	1.69	16	1.28	1.44	1.67
	25	10	0.59	1.71	1.97	12	0.76	1.52	1.76	15	1.12	1.44	1.66	17	1.45	1.45	1.67
	30	10	0.65	1.89	2.18	12	0.84	1.68	1.95	15	1.24	1.59	1.84	17	1.60	1.60	1.85
	35	11	0.71	1.70	1.96	13	0.91	1.56	1.80	16	1.35	1.52	1.76	18	1.74	1.55	1.79
180°	20	9	0.78	1.86	2.15	11	1.01	1.60	1.85	14	1.49	1.46	1.69	16	1.92	1.44	1.67
	25	10	0.89	1.71	1.97	12	1.14	1.52	1.76	15	1.68	1.44	1.66	17	2.17	1.45	1.67
	30	10	0.98	1.89	2.18	12	1.26	1.68	1.95	15	1.86	1.59	1.84	17	2.40	1.60	1.85
	35	11	1.07	1.70	1.96	13	1.37	1.56	1.80	16	2.02	1.52	1.76	18	2.61	1.55	1.79
240°	20	9	1.05	1.86	2.15	11	1.34	1.60	1.85	14	1.98	1.46	1.69	16	2.56	1.44	1.67
	25	10	1.18	1.71	1.97	12	1.52	1.52	1.76	15	2.24	1.44	1.66	17	2.89	1.45	1.67
	30	10	1.31	1.89	2.18	12	1.68	1.68	1.95	15	2.48	1.59	1.84	17	3.20	1.60	1.85
	35	11	1.42	1.70	1.96	13	1.83	1.56	1.80	16	2.70	1.52	1.76	18	3.48	1.55	1.79
270°	20	9	1.18	1.86	2.15	11	1.51	1.60	1.85	14	2.23	1.46	1.69	16	2.88	1.44	1.67
	25	10	1.33	1.71	1.97	12	1.71	1.52	1.76	15	2.52	1.44	1.66	17	3.26	1.45	1.67
	30	10	1.47	1.89	2.18	12	1.89	1.68	1.95	15	2.79	1.59	1.84	17	3.60	1.60	1.85
	35	11	1.60	1.70	1.96	13	2.06	1.56	1.80	16	3.04	1.52	1.76	18	3.92	1.55	1.79
360°	20	9	1.57	1.86	2.15	11	2.02	1.60	1.85	14	2.98	1.46	1.69	16	3.84	1.44	1.67
	25	10	1.77	1.71	1.97	12	2.28	1.52	1.76	15	3.37	1.44	1.66	17	4.34	1.45	1.67
	30	10	1.96	1.89	2.18	12	2.52	1.68	1.95	15	3.72	1.59	1.84	17	4.80	1.60	1.85
	35	11	2.13	1.70	1.96	13	2.74	1.56	1.80	16	4.05	1.52	1.76	18	5.22	1.55	1.79
40	11	2.30	1.83	2.11	13	2.95	1.68	1.94	17	4.36	1.45	1.68	19	5.62	1.50	1.73	

Note: Optimum nozzle performance shown in bold.

Strip Pattern Nozzle Performance Data

Color Code: Blue

Nozzle Model	Pressure PSI	Width x Length (ft)	Flow GPM
SS-530	20	4 x 28	1.10
	25	5 x 30	1.20
Side Strip	30	5 x 30	1.30
	35	5 x 30	1.40
	40	5 x 30	1.50

SPRAYS

PRO-SPRAY®

APPLICATION

Residential/Commercial

MODELS

Shrub, 2", 3", 4", 6", 12"

RESIDENTIAL OR COMMERCIAL, THIS VERSATILE SPRINKLER IS THE CONTRACTOR'S CHOICE.

FEATURES

- Application: Residential/commercial
- Models: Shrub, 2", 3", 4", 6", 12"
- No side inlet (NSI) version available in 6" and 12"
- Warranty period: 5 years

ADVANCED FEATURES

- Co-molded wiper seal with UV resistant material
- Body cap won't leak under high pressure
- Drain check valve (optional)
- = Detailed description on page 41
- Heavy-duty retraction spring
- Innovative directional flush plug design
- Reclaimed purple body cap (optional)
- Compatible with all female threaded nozzles

OPERATING SPECIFICATIONS

Recommended pressure range: 15 to 100 PSI

FACTORY INSTALLED OPTIONS

Drain check valve (up to 10' of elevation)
Reclaimed water ID cap

USER INSTALLED OPTIONS

Drain check valve (up to 10' of elevation; P/N 437400)
Reclaimed water ID cap (P/N 458520)
Snap-on reclaimed cover (P/N PROSRCCAP)

Pro-Spray models come with optional factory-installed purple reclaimed caps.



WORKS BEST WITH

MP ROTATOR

PRO-SPRAY FIXED ARC NOZZLES

PRO ADJUSTABLE NOZZLES

SPECIFICATIONBUILDER

hunterindustries.com/PROSPRAY

STANDARD MODELS	OPTIONS
PROS-00 = Shrub adapter	(blank) = No option
PROS-02 = 2" pop-up	CV = Factory-installed drain check valve (pop-up models only)
PROS-03 = 3" pop-up	CV-R = Factory-installed reclaimed body cap (shrub molded in purple)
PROS-04 = 4" pop-up	
PROS-06 = 6" pop-up	
PROS-06-NSI = 6" pop-up with no side inlet	6" and 12" models ordered as CV will come as no side inlet
PROS-12 = 12" pop-up	
PROS-12-NSI = 12" pop-up with no side inlet	

EXAMPLES

PROS-04 - 10A	4" pop-up, and 10' adjustable nozzle
PROS-06 - CV - 12H	6" pop-up, drain check valve, and 12' half circle nozzle
PROS-12 - CV-R - RCS	12" pop-up, drain check valve, reclaimed body cap, and right corner strip



PROS-00: Overall height: 1½"
Inlet size: ½" Female NPT



PROS-02: Overall height: 4"
Pop-up height: 2"
Exposed diameter: 2¼"
Inlet size: ½" Female NPT



PROS-03: Overall height: 5"
Pop-up height: 3"
Exposed diameter: 2¼"
Inlet size: ½" Female NPT



PROS-04: Overall height: 5½"
Pop-up height: 4"
Exposed diameter: 2¼"
Inlet size: ½" Female NPT



PROS-06: Overall height: 8¾"
PROS-06-NSI (right):
Pop-up height: 6"
Exposed diameter: 2¼"
Inlet size: ½" Female NPT

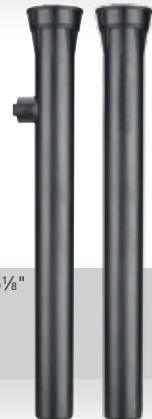

PROS-12: Overall height: 16½"
PROS-12-NSI (right)
Pop-up height: 12"
Exposed diameter: 2¼"
Inlet size: ½" Female NPT

SPRAYS

PRS30

APPLICATION

Residential/Commercial

MODELS

Shrub, 4", 6", 12"

KEEP WATER PRESSURE AT A TRUE 30 PSI FOR COMMERCIAL SITES TO REDUCE WASTE AND MAXIMIZE PERFORMANCE.

FEATURES

- Application: Residential/commercial
- Models: Shrub, 4", 6", 12"
- No side inlet (NSI) version available in 6" and 12"
- Warranty period: 5 years

ADVANCED FEATURES

- Identification cap is brown for easy field ID
- Pressure regulated to 30 PSI
- Co-molded wiper seal with UV resistant material
- Body cap won't leak under high pressure
- = Detailed description on page 41
- Drain check valve (optional)
- Heavy-duty retraction spring
- Innovative directional flush plug design
- Reclaimed purple body cap (optional)
- Compatible with all female threaded nozzles

OPERATING SPECIFICATIONS

Recommended pressure range: 15 to 100 PSI

FACTORY INSTALLED OPTIONS

Drain check valve (up to 14' of elevation)
Reclaimed water ID cap

USER INSTALLED OPTIONS

Vandal-proof cap (P/N PROS-PRS30-VPC)
Drain check valve (up to 14' of elevation; P/N 457400)
Reclaimed water ID cap (P/N 458530)
Snap-on reclaimed cover (P/N PROSRCCAP)

PRS30 formerly Institutional Spray

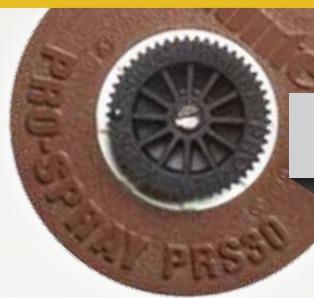

PROS-00-PRS-30:
Overall height: 4½"
Inlet size: ½" Female NPT

PROS-04-PRS30: Overall height: 5½"
Pop-up height: 4"
Exposed diameter: 2¼"
Inlet size: ½" Female NPT



PROS-06-PRS30: Overall height: 8¾"
PROS-06-PRS30-NSI (right)
Pop-up height: 6"
Exposed diameter: 2¼"
Inlet size: ½" Female NPT



PROS-12-PRS30: Overall height: 16½"
PROS-12-NSI-PRS30 (right)
Pop-up height: 12"
Exposed diameter: 2¼"
Inlet size: ½" Female NPT

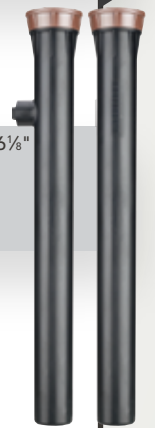

WORKS BEST WITH

PRO-SPRAY FIXED ARC NOZZLES

PRO ADJUSTABLE NOZZLES

SPECIFICATIONBUILDER

hunterindustries.com/PRS30

PRS30 MODELS (formerly Institutional Spray)	OPTIONS
PROS-00-PRS30 = 30 PSI regulated shrub adapter	(blank) = No option
PROS-04-PRS30 = 30 PSI regulated 4" pop-up	CV = Factory-installed drain check valve (pop-up models only)
PROS-06-PRS30 = 30 PSI regulated 6" pop-up	CV-R = Factory-installed drain check valve and reclaimed body cap (shrub molded in purple)
PROS-06-NSI-PRS30 = 30 PSI regulated 6" pop-up with no side inlet	
PROS-12-PRS30 = 30 PSI regulated 12" pop-up	6" and 12" models ordered as CV will come as no side inlet
PROS-12-NSI-PRS30 = 30 PSI regulated 12" pop-up with no side inlet	

EXAMPLES

PROS-04-PRS30	4" pop-up regulated at 30 PSI
PROS-06-PRS30 - CV - 12H	6" pop-up regulated at 30 PSI, drain check valve, and 12' half circle nozzle
PROS-12-PRS30 - CV-R - 10A	12" pop-up regulated at 30 PSI, drain check valve, reclaimed body cap, and 10' adjustable nozzle



PRS40

APPLICATION

Residential/Commercial

MODELS

Shrub, 4", 6", 12"

PRS40 IS DESIGNED FOR OPTIMAL PERFORMANCE AT 40 PSI WHEN PAIRED WITH THE REVOLUTIONARY MP ROTATOR.

FEATURES

- Application: Residential/commercial
- Models: Shrub, 4", 6", 12"
- No side inlet (NSI) version available in 6" and 12"
- Warranty period: 5 years

ADVANCED FEATURES

- Identification cap is gray for easy field ID
- Pressure regulated to 40 PSI
- Co-molded wiper seal with UV resistant material
- Drain check valve (up to 14' of elevation)
- Body cap won't leak under high pressure
- = Detailed description on page 41
- Heavy-duty retraction spring
- Innovative directional flush plug design
- Reclaimed purple body cap (optional)
- Compatible with all female threaded nozzles

OPERATING SPECIFICATIONS

Recommended pressure range: 15 to 100 PSI

FACTORY INSTALLED OPTIONS

Reclaimed water ID cap

USER INSTALLED OPTIONS

Reclaimed water ID cap (P/N 458530)

Snap-on reclaimed cover (P/N PROSRCCAP)

PRS40 formerly MPR40



PRESSURE
REGULATED AT
40 PSI



PROS-00-PRS40:
Overall height: 4½"
Inlet size: ½" Female NPT



PROS-04-PRS40:
Overall height: 5⅞"
Pop-up height: 4"
Exposed diameter: 2¼"
Inlet size: ½" Female NPT



PROS-06-PRS40-CV: Overall height: 8¾"
Pop-up height: 6"
Exposed diameter: 2¼"
Inlet size: ½" Female NPT



PROS-12-PRS40-CV:
Overall height: 16⅞"
Pop-up height: 12"
Exposed diameter: 2¼"
Inlet size: ½" Female NPT



DESIGNED SPECIFICALLY FOR

MP ROTATOR

SPECIFICATIONBUILDER

hunterindustries.com/PRS40

PRS40 MODELS (formerly MPR40)	OPTIONS
PROS-00-PRS40 = 40 PSI regulated shrub adapter	(blank) = No option
PROS-04-PRS40-CV = 40 PSI regulated 4" pop-up	R = Factory-installed reclaimed body cap (shrub molded in purple)
PROS-06-PRS40-CV = 40 PSI regulated 6" pop-up	6" and 12" models will come as no side inlet
PROS-12-PRS40-CV = 40 PSI regulated 12" pop-up	

EXAMPLES

PROS-04-PRS40-CV	4" pop-up regulated at 40 PSI, and drain check valve
PROS-06-PRS40-CV	6" pop-up regulated at 40 PSI, and drain check valve
PROS-12-PRS40-CV - R	12" pop-up regulated at 40 PSI, drain check valve, and reclaimed body cap
PROS-06-PRS40-CV-MP200090	6" pop-up regulated at 40 PSI, drain check valve, with MP 2000 90-210°

NOZZLES

ANGLING FOR PERFECTION? Hunter nozzles leave site constraints behind. From narrow strips to curving hillsides, any installation will benefit from optimum distribution designed to exacting standards.

PRO ADJUSTABLE NOZZLES

PRO ADJUSTABLE NOZZLES ARE THE ALL-IN-ONE CHOICE FOR OPTIMAL COVERAGE.

FEATURES

- Crisp, well-defined edges
- Matched precipitation rate from 8' to 17'
- Easy grip top for simple adjustment
- Designed with large water droplets to withstand light winds
- Even distribution results in beautiful pattern
- New 4' and 6' Pro Adjustable Nozzles provide additional flexibility
- Color-coded for easy field identification
- Adjustable from 0° to 360°

OPERATING SPECIFICATIONS

Recommended operating pressure: 30 PSI

Specify the new Pro-Spray® PRS30 pop-up for accurate pressure regulation of 30 PSI



Pro Adjustable Nozzles Performance Data

Arc	Pressure PSI	4 Foot Radius Adjustable: 0° - 360° Trajectory: 0° Color Code: Lt. Green				6 Foot Radius Adjustable: 0° - 360° Trajectory: 0° Color Code: Lt. Blue			
		Radius ft.	Flow GPM	Precip in/hr		Radius ft.	Flow GPM	Precip in/hr	
45°	20	3	0.11	5.44	6.28	5	0.15	3.21	3.70
	25	3	0.13	6.02	6.95	5	0.15	3.21	3.70
	30	4	0.13	6.45	7.45	6	0.18	3.85	4.45
	35	4	0.14	6.74	7.78	6	0.18	3.85	4.45
90°	20	3	0.19	4.57	5.28	5	0.30	3.21	3.70
	25	3	0.20	4.81	5.56	5	0.31	3.32	3.83
	30	4	0.28	6.74	7.78	6	0.37	3.96	4.57
	35	4	0.24	5.78	6.67	6	0.38	4.06	4.69
120°	20	3	0.25	5.90	6.81	6	0.40	4.28	4.94
	25	3	0.28	5.05	5.84	5	0.37	2.97	3.43
	30	4	0.34	6.14	7.09	6	0.44	3.53	4.08
	35	4	0.34	6.14	7.09	6	0.46	3.69	4.26
180°	20	4	0.37	6.68	7.71	6	0.48	3.85	4.45
	25	3	0.34	4.09	4.72	5	0.50	2.67	3.09
	30	4	0.45	5.41	6.25	6	0.60	3.21	3.70
	35	4	0.46	5.53	6.39	6	0.64	3.42	3.95
240°	20	4	0.48	5.78	6.67	6	0.68	3.64	4.20
	25	3	0.58	5.23	6.04	5	0.73	2.93	0.85
	30	4	0.68	6.13	7.08	6	0.88	3.53	1.02
	35	4	0.74	6.68	7.71	6	0.92	3.69	1.07
270°	20	4	0.80	7.22	8.34	6	1.02	4.09	1.18
	25	3	0.59	4.73	5.46	5	0.88	3.14	3.62
	30	4	0.73	5.86	6.76	6	1.10	3.92	4.53
	35	4	0.76	6.10	7.04	6	1.15	4.10	4.73
360°	20	4	0.80	6.42	7.41	6	1.20	4.28	4.94
	25	3	0.66	3.97	4.58	5	1.05	2.81	3.24
	30	4	0.72	4.33	5.00	6	1.10	2.94	3.40
	35	4	0.86	5.17	5.97	6	1.30	3.48	4.01
	40	4	0.90	5.41	6.25	6	1.40	3.74	4.32

Note: The Pro-Spray PRS30's built-in pressure regulator controls output to a maximum of 30 PSI. Optimum nozzle performance shown in bold. Turning the radius reduction screw may be required to achieve catalog radius and flow.

PRO ADJUSTABLE NOZZLES CHART

Pro Adjustable Nozzles Performance Data

		8 Foot Radius Adjustable: 0° - 360° Trajectory: 0° Color Code: Brown				10 Foot Radius Adjustable: 0° - 360° Trajectory: 15° Color Code: Red			
		Nozzle		Nozzle		Nozzle		Nozzle	
		8A		8A		10A		10A	
Arc	Pressure PSI	Radius ft.	Flow GPM	Precip in/hr	Precip in/hr	Radius ft.	Flow GPM	Precip in/hr	Precip in/hr
45°	20	7	0.12	1.83	2.11	9	0.20	1.86	2.15
	25	8	0.13	1.58	1.83	10	0.22	1.71	1.97
	30	8	0.15	1.75	2.02	10	0.25	1.89	2.18
	35	9	0.16	1.51	1.74	11	0.27	1.70	1.96
90°	20	7	0.23	1.83	2.11	9	0.39	1.86	2.15
	25	8	0.26	1.58	1.83	10	0.44	1.71	1.97
	30	8	0.29	1.75	2.02	10	0.49	1.89	2.18
	35	9	0.32	1.51	1.74	11	0.53	1.70	1.96
120°	20	7	0.31	1.83	2.11	9	0.52	1.86	2.15
	25	8	0.35	1.58	1.83	10	0.59	1.71	1.97
	30	8	0.39	1.75	2.02	10	0.65	1.89	2.18
	35	9	0.42	1.51	1.74	11	0.71	1.70	1.96
180°	20	7	0.47	1.83	2.11	9	0.78	1.86	2.15
	25	8	0.53	1.58	1.83	10	0.89	1.71	1.97
	30	8	0.58	1.75	2.02	10	0.98	1.89	2.18
	35	9	0.63	1.51	1.74	11	1.07	1.70	1.96
240°	20	7	0.62	1.83	2.11	9	1.05	1.86	2.15
	25	8	0.70	1.58	1.83	10	1.18	1.71	1.97
	30	8	0.78	1.75	2.02	10	1.31	1.89	2.18
	35	9	0.84	1.51	1.74	11	1.42	1.70	1.96
270°	20	7	0.70	1.83	2.11	9	1.18	1.86	2.15
	25	8	0.79	1.58	1.83	10	1.33	1.71	1.97
	30	8	0.87	1.75	2.02	10	1.47	1.89	2.18
	35	9	0.95	1.51	1.74	11	1.60	1.70	1.96
360°	20	7	0.93	1.83	2.11	9	1.57	1.86	2.15
	25	8	1.05	1.58	1.83	10	1.77	1.71	1.97
	30	8	1.16	1.75	2.02	10	1.96	1.89	2.18
	35	9	1.27	1.51	1.74	11	2.13	1.70	1.96
40	9	1.36	1.62	1.87	11	2.30	1.83	2.11	



NOZZLES

Pro Adjustable Nozzles Performance Data

		12 Foot Radius Adjustable: 0° - 360° Trajectory: 28° Color Code: Green				15 Foot Radius Adjustable: 0° - 360° Trajectory: 28° Color Code: Black				17 Foot Radius Adjustable: 0° - 360° Trajectory: 28° Color Code: Gray			
		Nozzle		Nozzle		Nozzle		Nozzle		Nozzle		Nozzle	
		12A		12A		15A		15A		17A		17A	
Arc	Pressure PSI	Radius ft.	Flow GPM	Precip in/hr	Precip in/hr	Radius ft.	Flow GPM	Precip in/hr	Precip in/hr	Radius ft.	Flow GPM	Precip in/hr	Precip in/hr
45°	20	11	0.25	1.60	1.85	14	0.37	1.46	1.69	16	0.48	1.44	1.67
	25	12	0.28	1.52	1.76	15	0.42	1.44	1.66	17	0.54	1.45	1.67
	30	12	0.32	1.68	1.95	15	0.47	1.59	1.84	17	0.60	1.60	1.85
	35	13	0.34	1.56	1.80	16	0.51	1.52	1.76	18	0.65	1.55	1.79
90°	20	11	0.50	1.60	1.85	14	0.74	1.46	1.69	16	0.96	1.44	1.67
	25	12	0.57	1.52	1.76	15	0.84	1.44	1.66	17	1.09	1.45	1.67
	30	12	0.63	1.68	1.95	15	0.93	1.59	1.84	17	1.20	1.60	1.85
	35	13	0.69	1.56	1.80	16	1.01	1.52	1.76	18	1.31	1.55	1.79
120°	20	11	0.74	1.68	1.94	17	1.09	1.45	1.68	19	1.41	1.50	1.73
	25	11	0.67	1.60	1.85	14	0.99	1.46	1.69	16	1.28	1.44	1.67
	30	12	0.76	1.52	1.76	15	1.12	1.44	1.66	17	1.45	1.45	1.67
	35	13	0.91	1.56	1.80	16	1.35	1.52	1.76	18	1.74	1.55	1.79
180°	20	11	0.98	1.68	1.94	17	1.45	1.45	1.68	19	1.87	1.50	1.73
	25	11	1.01	1.60	1.85	14	1.49	1.46	1.69	16	1.92	1.44	1.67
	30	12	1.14	1.52	1.76	15	1.68	1.44	1.66	17	2.17	1.45	1.67
	35	13	1.37	1.56	1.80	16	2.02	1.52	1.76	18	2.61	1.55	1.79
240°	20	11	1.48	1.68	1.94	17	2.18	1.45	1.68	19	2.81	1.50	1.73
	25	11	1.34	1.60	1.85	14	1.98	1.46	1.69	16	2.56	1.44	1.67
	30	12	1.52	1.52	1.76	15	2.24	1.44	1.66	17	2.89	1.45	1.67
	35	13	1.83	1.56	1.80	16	2.70	1.52	1.76	18	3.48	1.55	1.79
270°	20	11	1.97	1.68	1.94	17	2.91	1.45	1.68	19	3.75	1.50	1.73
	25	11	1.51	1.60	1.85	14	2.23	1.46	1.69	16	2.88	1.44	1.67
	30	12	1.71	1.52	1.76	15	2.52	1.44	1.66	17	3.26	1.45	1.67
	35	13	2.06	1.56	1.80	16	3.04	1.52	1.76	18	3.92	1.55	1.79
360°	20	11	2.21	1.68	1.94	17	3.27	1.45	1.68	19	4.22	1.50	1.73
	25	11	2.02	1.60	1.85	14	2.98	1.46	1.69	16	3.84	1.44	1.67
	30	12	2.28	1.52	1.76	15	3.37	1.44	1.66	17	4.34	1.45	1.67
	35	13	2.74	1.56	1.80	16	4.05	1.52	1.76	18	5.22	1.55	1.79
40	13	2.95	1.68	1.94	17	4.36	1.45	1.68	19	5.62	1.50	1.73	

Note: The Pro-Spray PRS30's built-in pressure regulator controls output to a maximum of 30 PSI. Optimum nozzle performance shown in bold.

PRO-SPRAY® FIXED ARC NOZZLES

GIVE YOUR SPRAYS SOME EDGE. WHEN PRECISION IS IMPERATIVE, PRO-SPRAY FIXED NOZZLES HAVE IT COVERED.

FEATURES

- Color-coded for easy field identification
- Optimum droplet size minimizes misting while maximizing uniformity
- New 1/3, 2/3, and 3/4 arc options for increased flexibility

OPERATING SPECIFICATIONS

Recommended operating pressure: 30 PSI

Specify the new Pro-Spray® PRS30 pop-up for accurate pressure regulation of 30 PSI



NOZZLES

PRO-SPRAY® FIXED ARC NOZZLE CHART

Pro-Spray® Fixed Arc Nozzles Performance Data														
Arc	Pattern	Pressure PSI	5 Foot Radius Fixed: 1/4, 1/2, Full Trajectory: 0° Color Code: Blue				8 Foot Radius Fixed: 1/4, 1/3, 1/2, Full Trajectory: 0° Color Code: Brown				10 Foot Radius Fixed: 1/4, 1/3, 1/2, Full Trajectory: 15° Color Code: Red			
			Radius ft.	Flow GPM	Precip in/hr		Radius ft.	Flow GPM	Precip in/hr		Radius ft.	Flow GPM	Precip in/hr	
90°	Q	20	4	0.09	2.25	2.60	7	0.20	1.54	1.78	9	0.34	1.63	1.88
		25	4	0.11	2.54	2.94	8	0.22	1.33	1.53	10	0.39	1.48	1.71
		30	5	0.12	1.80	2.08	8	0.24	1.46	1.69	10	0.42	1.63	1.89
		35	6	0.13	1.36	1.57	9	0.26	1.25	1.45	11	0.46	1.47	1.69
		40	6	0.14	1.46	1.69	9	0.28	1.34	1.55	11	0.49	1.57	1.82
120°	T	20	Use Hunter 4A or 6A Nozzle				7	0.26	1.54	1.78	9	0.46	1.63	1.88
		25					8	0.29	1.33	1.53	10	0.51	1.48	1.71
		30					8	0.32	1.46	1.69	10	0.57	1.63	1.89
		35					9	0.35	1.25	1.45	11	0.61	1.47	1.69
		40					9	0.38	1.34	1.55	11	0.66	1.57	1.82
180°	H	20	4	0.19	2.25	2.60	7	0.38	1.49	1.72	9	0.70	1.67	1.92
		25	4	0.21	2.54	2.94	8	0.43	1.28	1.48	10	0.79	1.53	1.76
		30	5	0.23	1.80	2.08	8	0.47	1.41	1.63	10	0.88	1.69	1.95
		35	6	0.25	1.36	1.57	9	0.51	1.21	1.39	11	0.95	1.52	1.75
		40	6	0.27	1.46	1.69	9	0.54	1.29	1.49	11	1.03	1.63	1.89
240°	TT	20	Use Hunter 4A or 6A Nozzle				Use Hunter 8A Nozzle				Use Hunter 10A Nozzle			
		25	Use Hunter 4A or 6A Nozzle				Use Hunter 8A Nozzle				Use Hunter 10A Nozzle			
		30	Use Hunter 4A or 6A Nozzle				Use Hunter 8A Nozzle				Use Hunter 10A Nozzle			
		35	Use Hunter 4A or 6A Nozzle				Use Hunter 8A Nozzle				Use Hunter 10A Nozzle			
		40	Use Hunter 4A or 6A Nozzle				Use Hunter 8A Nozzle				Use Hunter 10A Nozzle			
270°	TQ	20	Use Hunter 4A or 6A Nozzle				Use Hunter 8A Nozzle				Use Hunter 10A Nozzle			
		25	Use Hunter 4A or 6A Nozzle				Use Hunter 8A Nozzle				Use Hunter 10A Nozzle			
		30	Use Hunter 4A or 6A Nozzle				Use Hunter 8A Nozzle				Use Hunter 10A Nozzle			
		35	Use Hunter 4A or 6A Nozzle				Use Hunter 8A Nozzle				Use Hunter 10A Nozzle			
		40	Use Hunter 4A or 6A Nozzle				Use Hunter 8A Nozzle				Use Hunter 10A Nozzle			
360°	F	20	4	0.37	2.25	2.60	7	0.78	1.54	1.78	9	1.29	1.53	1.77
		25	4	0.42	2.54	2.94	8	0.88	1.33	1.53	10	1.45	1.39	1.61
		30	5	0.47	1.80	2.08	8	0.97	1.46	1.69	10	1.59	1.53	1.76
		35	6	0.51	1.36	1.57	9	1.05	1.25	1.45	11	1.72	1.37	1.58
		40	6	0.55	1.46	1.69	10	1.13	1.34	1.55	11	1.84	1.46	1.69

Pro-Spray® Fixed Arc Nozzles Performance Data														
Arc	Pattern	Pressure PSI	12 Foot Radius Fixed 1/4, 1/3, 1/2, 2/3, 3/4, Full Trajectory: 28° Color Code: Green				15 Foot Radius Fixed 1/4, 1/3, 1/2, 2/3, 3/4, Full Trajectory: 28° Color Code: Black				17 Foot Radius Fixed 1/4, 1/2 Trajectory: 28° Color Code: Gray			
			Radius ft.	Flow GPM	Precip in/hr		Radius ft.	Flow GPM	Precip in/hr		Radius ft.	Flow GPM	Precip in/hr	
90°	Q	20	11	0.54	1.71	1.98	14	0.78	1.53	1.77	16	0.93	1.40	1.61
		25	12	0.61	1.62	1.87	15	0.88	1.51	1.74	17	1.05	1.39	1.61
		30	12	0.67	1.78	2.06	15	0.97	1.67	1.92	17	1.15	1.54	1.77
		35	13	0.72	1.65	1.90	16	1.06	1.59	1.84	18	1.25	1.49	1.72
		40	13	0.78	1.77	2.04	17	1.14	1.52	1.75	19	1.34	1.43	1.65
120°	T	20	11	0.72	1.71	1.98	14	1.04	1.53	1.77	Use Hunter 17A Nozzle			
		25	12	0.81	1.62	1.87	15	1.17	1.51	1.74				
		30	12	0.89	1.78	2.06	15	1.30	1.67	1.92				
		35	13	0.97	1.65	1.90	16	1.41	1.59	1.84				
		40	13	1.04	1.77	2.04	17	1.52	1.52	1.75				
180°	H	20	11	1.05	1.67	1.93	14	1.51	1.48	1.71	16	1.91	1.43	1.66
		25	12	1.18	1.58	1.83	15	1.69	1.45	1.67	17	2.15	1.43	1.65
		30	12	1.30	1.74	2.01	15	1.86	1.59	1.84	17	2.37	1.58	1.82
		35	13	1.42	1.61	1.86	16	2.02	1.52	1.75	18	2.57	1.53	1.76
		40	13	1.52	1.73	2.00	17	2.16	1.44	1.66	19	2.76	1.47	1.70
240°	TT	20	11	1.40	1.67	1.93	14	2.01	1.48	1.71	Use Hunter 17A Nozzle			
		25	12	1.58	1.58	1.83	15	2.26	1.45	1.67				
		30	12	1.74	1.74	2.01	15	2.48	1.59	1.84				
		35	13	1.89	1.61	1.86	16	2.69	1.52	1.75				
		40	13	2.03	1.73	2.00	17	2.88	1.44	1.66				
270°	TQ	20	11	1.61	1.67	1.93	14	2.34	1.48	1.71	Use Hunter 17A Nozzle			
		25	12	1.82	1.58	1.83	15	2.64	1.45	1.67				
		30	12	2.00	1.74	2.01	15	2.92	1.59	1.84				
		35	13	2.17	1.61	1.86	16	3.18	1.52	1.75				
		40	13	2.33	1.73	2.00	17	3.42	1.44	1.66				
360°	F	20	11	2.17	1.72	1.99	14	3.04	1.49	1.72	Use Hunter 17A Nozzle			
		25	12	2.45	1.63	1.89	15	3.41	1.46	1.69				
		30	12	2.70	1.80	2.08	15	3.75	1.61	1.85				
		35	13	2.93	1.67	1.93	16	4.07	1.53	1.76				
		40	13	3.15	1.80	2.07	17	4.36	1.45	1.68				

Note: Optimum nozzle performance shown in bold.

NOZZLES

SHORT RADIUS NOZZLES

Small space solution in short order. When you need controlled irrigation for smaller spaces, these nozzles have small spaces covered. Available in 2', 4', and 6' radius versions.



Short Radius Nozzles Performance Data

Arc	Pressure PSI	Color Code: Light Brown				Color Code: Light Green				Color Code: Light Blue						
		Nozzle	Radius ft.	Flow GPM	Precip in/hr	Nozzle	Radius ft.	Flow GPM	Precip in/hr	Nozzle	Radius ft.	Flow GPM	Precip in/hr			
90°	20	2Q	2	0.09	8.66	10.00	4Q	4	0.20	4.81	5.56	6Q	6	0.47	5.03	5.80
	25		2	0.10	9.63	11.11		4	0.22	5.29	6.11		6	0.49	5.24	6.05
	30		2	0.11	10.59	12.23		4	0.22	5.29	6.11		6	0.51	5.45	6.30
	35		2	0.12	11.55	13.34		4	0.24	5.78	6.67		6	0.52	5.56	6.42
	40		2	0.14	13.48	15.56		4	0.24	5.78	6.67		6	0.52	5.56	6.42
180°	20	2H	2	0.12	5.78	6.67	4H	4	0.41	4.93	5.70	6H	6	0.95	5.08	5.87
	25		2	0.14	6.74	7.78		4	0.43	5.17	5.97		6	0.97	5.19	5.99
	30		2	0.16	7.70	8.89		4	0.44	5.29	6.11		6	0.98	5.24	6.05
	35		2	0.18	8.66	10.00		4	0.46	5.53	6.39		6	0.99	5.29	6.11
	40		2	0.18	8.66	10.00		4	0.46	5.53	6.39		6	1.00	5.35	6.17

STRIP PATTERN NOZZLES

Dealing with narrow planting areas? Narrow site constraints are no big deal when you have great nozzle options. Choose from center and end strips or corner and side strips. Either way, you'll enjoy optimum distribution from nozzles designed to exacting standards.



Strip Pattern Nozzle Performance Data

Color Code: Blue			
Nozzle Model	Pressure PSI	Width x Length	Flow GPM
LCS-515 Left-Corner Strip	20	4 x 14	0.55
	25	5 x 15	0.60
	30	5 x 15	0.65
	35	5 x 15	0.70
RCS-515 Right-Corner Strip	20	4 x 14	0.55
	25	5 x 15	0.60
	30	5 x 15	0.65
	35	5 x 15	0.70
SS-530 Side Strip	20	4 x 28	1.10
	25	5 x 30	1.20
	30	5 x 30	1.30
	35	5 x 30	1.40
ES-515 End Strip	20	4 x 14	0.55
	25	5 x 15	0.60
	30	5 x 15	0.65
	35	5 x 15	0.70
CS-530 Center Strip	20	4 x 28	1.10
	25	5 x 30	1.20
	30	5 x 30	1.30
	35	5 x 30	1.40
SS-918 Side Strip	20	8 x 17	1.45
	25	9 x 18	1.58
	30	9 x 18	1.72
	35	9 x 18	1.88
40	9 x 18	2.08	

NOZZLES/BUBBLERS

STREAM NOZZLES

These adjustable arc models offer fixed streams of water reaching 8' or 16'. Each stream has more energy than traditional sprays making them the ideal choice for ground cover and shrub applications.

STREAM SPRAY NOZZLES



Model S-8A Stream Spray Nozzle Performance Data

Adjustable: 25° to 360°		Color Code: Blue			
Arc	Pressure PSI	Radius ft.	Flow GPM	Precip in/hr	
90°	20	7	0.29	2.28	2.63
	25	8	0.32	1.93	2.22
	30	8	0.35	2.11	2.43
	35	8	0.38	2.29	2.64
40	9	0.41	1.95	2.25	
180°	20	7	0.54	2.12	2.45
	25	8	0.57	1.71	1.98
	30	8	0.60	1.80	2.08
	35	8	0.63	1.89	2.19
40	9	0.66	1.57	1.81	
360°	20	7	1.08	2.12	2.45
	25	8	1.11	1.67	1.93
	30	8	1.15	1.73	2.00
	35	8	1.18	1.77	2.05
40	9	1.22	1.45	1.67	

Model S-16A Stream Spray Nozzle Performance Data

Adjustable: 25° to 360°		Color Code: Blue			
Arc	Pressure PSI	Radius ft.	Flow GPM	Precip in/hr	
90°	20	15	0.40	0.68	0.79
	25	16	0.46	0.69	0.80
	30	16	0.50	0.75	0.87
	35	17	0.54	0.72	0.83
40	18	0.57	0.68	0.78	
180°	20	15	0.67	0.57	0.66
	25	16	0.80	0.60	0.69
	30	16	0.88	0.66	0.76
	35	17	0.97	0.65	0.75
40	18	1.04	0.62	0.71	
360°	20	15	1.19	0.51	0.59
	25	16	1.46	0.55	0.63
	30	16	1.66	0.62	0.72
	35	17	1.82	0.61	0.70
40	18	1.99	0.59	0.68	

PRESSURE-COMPENSATING BUBBLERS AND BUBBLER NOZZLES

Hunter bubblers keep the output of water constant regardless of pressure, for precise, easy application. Every plant, shrub, and tree receives the right amount of water with no excess runoff or waste.

MULTI-STREAM BUBBLER NOZZLES – MSBN



Multi-Stream Bubbler Performance Data

Arc	Model	Flow GPM	Radius ft.
90°	MSBN-25Q	0.25	1.0
	MSBN-50Q	0.50	1.5
180°	MSBN-50H	0.50	1.0
	MSBN-10H	1.00	1.5
360°	MSBN-10F	1.00	1.0
	MSBN-20F	2.00	1.5

Note: Typical spacing 2 to 4 ft. Flows shown for pressures between 15 and 70 PSI.



PCN BUBBLER NOZZLES

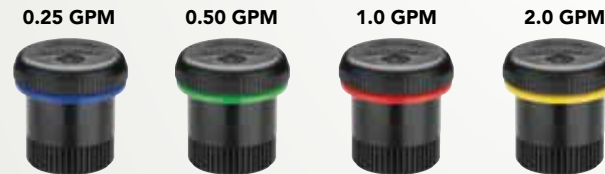

PCB / PCN & AFB Performance Data

Model	Flow GPM	Pattern Type
25	0.25	Trickle
50	0.50	Trickle
10	1.00	Umbrella
20	2.00	Umbrella

Note: Typical spacing 1 to 3 ft. Flows shown for pressures between 15 and 70 PSI. All PCB models available in reclaimed (purple) tops. Specify -R to the name (e.g., PCB-50-R).

PCB AND AFB BUBBLERS 1/2" INLET



DUAL-STREAM BUBBLER NOZZLES



5-CST-B Bubbler Nozzle Performance Data

	Pressure PSI	Radius ft.	Flow GPM
90°	20	5	0.30
	25	5	0.32
	30	5	0.38
	35	5	0.40
	40	5	0.42



MP ROTATOR

MP ROTATORS

A REVELATION IN CONSERVATION.

Intelligent water use is no longer optional. Today, it is everyone's responsibility. Setting a new precedent in efficiency, Hunter's MP Rotator has started the revolution to change an industry, one spray, one installation, and one retrofit at a time.



MP ROTATOR®

MP ROTATOR

APPLICATION
Residential/Commercial

RADIUS
8' to 30'

hunterindustries.com/MP

MP ROTATORS SAVE MORE WITH 30% INCREASED EFFICIENCY OVER SPRAYS.

FEATURES

- True matched precipitation any arc or radius setting
- Radius can be reduced up to 25% on all models
- Color-coded for easy identification
- Double-pop feature keeps dirt and debris out of nozzle
- Removable filter screen prevents large objects from clogging nozzle
- Low precipitation rate
- Wind-resistant multi-stream technology
- Adjustable arc and radius offer timely and precise settings

ADVANCED FEATURES

- Ratchet mechanism prevents damage when attempting to reduce radius too far
- Models can only be adjusted while water is running

OPERATING SPECIFICATIONS

Recommended operating pressure: 40 PSI
Models can only be adjusted while water is running

OPTIONS

Pair with Pro-Spray PRS40 to achieve pressure regulation at the head of 40 PSI
Adding "HT" will specify male threaded nozzles



MP1000 8' to 15' radius



MP100090 90° to 210°
MP1000210 210° to 270°
MP1000360 360°

MP2000 13' to 21' radius



MP200090 90° to 210°
MP2000210 210° to 270°
MP2000360 360°

MP3000 22' to 30' radius



MP300090 90° to 210°
MP3000210 210° to 270°
MP3000360 360°

MP STRIPS



MPLCS515 Left Corner 5' x 15'
MPRCS515 Right Corner 5' x 15'



MPSS530 Side Strip 5' x 30'
MPCORNER * Corner 8' to 15'

* Applies additional water first 3' from the pop-up when head to head coverage is not available

SPECIFICATIONBUILDER

MODELS	OPTIONS
MP1000-90 = 8' to 15' radius, adjustable from 90° to 210° MP1000-210 = 8' to 15' radius, adjustable from 210° to 270° MP1000-360 = 8' to 15' radius, 360°	(blank) = No option HT = Male thread version
MP2000-90 = 13' to 21' radius, adjustable from 90° to 210° MP2000-210 = 13' to 21' radius, adjustable from 210° to 270° MP2000-360 = 13' to 21' radius, 360°	
MP3000-90 = 22' to 30' radius, adjustable from 90° to 210° MP3000-210 = 22' to 30' radius, adjustable from 210° to 270° MP3000-360 = 22' to 30' radius, 360°	
MPLCS515 = Left corner strip 5' x 15'	
MPRCS515 = Right corner strip 5' x 15'	
MPSS530 = Side strip 5' x 30'	
MPCORNER = 8' to 15' radius, adjustable from 45° to 105°	(MP Rotators are designed to operate in conjunction with a pop-up sprinkler or shrub adapter.)

EXAMPLE

MP1000-210	8' to 15' radius, adjustable from 210° to 270°
PROS-06-PRS40-CV-MP200090	6" pop-up regulated at 40 PSI, drain check valve, with MP 2000 90-210°

MP ROTATORS

MP ROTATOR CHARTS

MP Rotator Performance Data

MP1000 Radius: 8' to 15' Adjustable Arc and Full Circle Color Code: Maroon, Lt. Blue, or Olive							MP2000 Radius: 13' to 21' Adjustable Arc and Full Circle Color Code: Black, Green, or Red					MP3000 Radius: 22' to 30' Adjustable Arc and Full Circle Color Code: Blue, Yellow, or Gray							
Arc	Pressure PSI	Color	Radius ft.	Flow GPM	Flow GPH	Precip in/hr ▲	Color	Radius ft.	Flow GPM	Flow GPH	Precip in/hr ▲	Color	Radius ft.	Flow GPM	Flow GPH	Precip in/hr ▲			
90°	25	Maroon = 90° to 210°	-	-	-	-	Black = 90° to 210°	17	0.31	18.6	0.41	0.48	Blue = 90° to 210°	25	0.69	41.4	0.43	0.49	
	30		12	0.16	9.6	0.43		0.50	18	0.33	19.8	0.39		0.45	27	0.74	44.4	0.39	0.45
	35		13	0.18	10.8	0.40		0.46	19	0.37	22.2	0.39		0.46	28	0.80	48	0.39	0.45
	40		14	0.19	11.4	0.39		0.45	20	0.40	24	0.39		0.44	30	0.86	51.6	0.37	0.43
	45		14	0.20	12	0.39		0.45	21	0.42	25.2	0.37		0.42	30	0.91	54.6	0.39	0.45
	50		14	0.21	12.6	0.38		0.43	21	0.44	26.4	0.35		0.40	30	0.96	57.6	0.41	0.47
180°	25	Maroon = 90° to 210°	-	-	-	-	Black = 90° to 210°	16	0.58	34.8	0.44	0.50	Blue = 90° to 210°	25	1.44	86.4	0.44	0.51	
	30		12	0.32	19.2	0.43		0.50	17	0.63	37.8	0.42		0.49	27	1.58	94.8	0.42	0.48
	35		13	0.35	21	0.40		0.46	18	0.69	41.4	0.41		0.47	28	1.70	102	0.42	0.48
	40		14	0.37	22.2	0.39		0.45	19	0.74	44.4	0.39		0.45	30	1.82	109.2	0.39	0.45
	45		14	0.40	24	0.39		0.45	20	0.78	46.8	0.38		0.43	30	1.93	115.8	0.41	0.48
	50		14	0.41	24.6	0.38		0.43	21	0.83	49.8	0.36		0.41	30	2.04	122.4	0.44	0.50
210°	25	Lt. Blue = 210° to 270°	-	-	-	-	Green = 210° to 270°	16	0.68	40.8	0.44	0.50	Yellow = 210° to 270°	25	1.68	100.8	0.44	0.51	
	30		12	0.37	22.2	0.43		0.50	17	0.74	44.4	0.42		0.49	27	1.84	110.4	0.42	0.48
	35		13	0.41	24.6	0.40		0.46	18	0.80	48	0.41		0.47	28	1.99	119.4	0.42	0.48
	40		14	0.43	25.8	0.39		0.45	19	0.86	51.6	0.39		0.45	30	2.12	127.2	0.39	0.45
	45		14	0.46	27.6	0.39		0.45	20	0.92	55.2	0.38		0.43	30	2.25	135	0.41	0.48
	50		14	0.48	28.8	0.38		0.43	21	0.97	58.2	0.36		0.41	30	2.37	142.2	0.43	0.50
270°	25	Lt. Blue = 210° to 270°	-	-	-	-	Green = 210° to 270°	16	0.87	52.2	0.44	0.50	Yellow = 210° to 270°	25	2.19	131.4	0.45	0.52	
	30		12	0.48	29	0.43		0.50	17	0.95	57	0.42		0.49	27	2.37	142.2	0.42	0.48
	35		13	0.54	32	0.40		0.46	18	1.03	61.8	0.41		0.47	28	2.55	153	0.42	0.48
	40		14	0.57	34	0.39		0.45	19	1.10	66	0.39		0.45	30	2.73	163.8	0.39	0.45
	45		14	0.60	36	0.39		0.45	20	1.17	70.2	0.38		0.43	30	2.89	173.4	0.41	0.48
	50		14	0.63	38	0.38		0.43	21	1.23	73.8	0.36		0.41	30	3.06	183.6	0.44	0.50
360°	25	Olive = 360°	-	-	-	-	Red = 360°	16	1.16	69.6	0.44	0.50	Gray = 360°	25	2.88	172.8	0.44	0.51	
	30		12	0.65	39	0.43		0.50	17	1.27	76.2	0.42		0.49	27	3.15	189	0.42	0.48
	35		13	0.71	42.6	0.40		0.47	18	1.37	82.2	0.41		0.47	28	3.40	204	0.42	0.48
	40		14	0.75	45	0.39		0.46	19	1.47	88.2	0.39		0.45	30	3.64	218.4	0.39	0.45
	45		14	0.80	48	0.39		0.45	20	1.56	93.6	0.38		0.43	30	3.86	231.6	0.41	0.48
	50		14	0.84	50.4	0.38		0.44	21	1.64	98.4	0.36		0.41	30	4.07	244.2	0.44	0.50
55	15	0.87	52.2	0.37	0.43	21	1.70	102	0.37	0.43	30	4.27	256.2	0.46	0.53				



WORKS BEST WITH PRS40

See page 47.

MP ROTATORS

MP Rotator Performance Data

MPCorner Radius: 8' to 15' Adjustable Arc Color Code: Turquoise					
Arc	Pressure PSI	Color	Radius ft.	Flow GPM	Flow GPH
45°	25	Turquoise = 45° to 105°	-	-	-
	30		12	0.17	10.2
	35		13	0.18	10.8
	40		14	0.19	11.4
	45		14	0.21	12.6
	50		14	0.22	13.2
90°	25	Turquoise = 45° to 105°	11	0.31	18.6
	30		12	0.34	20.4
	35		13	0.36	21.6
	40		14	0.39	23.4
	45		14	0.41	24.6
	50		15	0.43	25.8
105°	25	Turquoise = 45° to 105°	11	0.36	21.6
	30		12	0.39	23.4
	35		13	0.42	25.2
	40		14	0.45	27
	45		14	0.48	28.8
	50		15	0.51	30.6
55	15	0.53	31.8		

MP Rotator Performance Data

MPLCS515 MPRCS515 MPSS530					
Nozzle Model	Pressure PSI	Color	Width x Length (ft.)	Flow GPM	Flow GPH
MP Left Strip	30	Ivory	4 x 14	0.19	11.4
	35		5 x 15	0.21	12.6
	40		5 x 15	0.22	13.2
	45		5 x 15	0.23	13.8
	50		6 x 16	0.25	15
	55		6 x 16	0.26	15.6
MP Right Strip	30	Copper	4 x 14	0.19	11.4
	35		5 x 15	0.21	12.6
	40		5 x 15	0.22	13.2
	45		5 x 15	0.23	13.8
	50		6 x 16	0.25	15
	55		6 x 16	0.26	15.6
MP Side Strip	30	Brown	4 x 28	0.38	22.8
	35		5 x 30	0.41	24.6
	40		5 x 30	0.44	26.4
	45		5 x 30	0.47	28.2
	50		6 x 32	0.49	29.4
	55		6 x 32	0.51	30.6

Note: Strip pattern radius can be adjusted by 25%. MP Rotator is designed to maintain matched precipitation after radius adjustment.



MP STICK

The MP Stick snaps on to 1" PVC of any length to easily adjust MP Rotators while standing up.



MP TOOL

Adjustments to MP Rotators are simply a snap with this handy tool.



THE NEXT LEVEL OF CONTROL. Where others can claim only reliability, Hunter valves use that as a starting point. Dependability is a given when innovation is the standard. Fully loaded with features to take on any size project, from a residential micro irrigation zone to a large turf rotor zone, these valves do more than deliver. They raise the bar.

VALVES

COMPARISON CHART

	SRV	PGV Jar-Top	PGV	ICV	ICV Filter Sentry™	IBV	IBV Filter Sentry™	Drip Zone Control Kit*
APPLICATIONS								
Potable water	•	•	•	•	•	•	•	•
Reclaimed water				•	•	•	•	•
Secondary water					•		•	•
Pressure regulation	•	•	•	•	•	•	•	•
Flow control	•	•	•	•	•	•	•	•
Angle option			•	•				
High pressure systems				•	•	•	•	
Low pressure system	•	•	•	•	•	•	•	•
Residential	•	•	•					•
Commercial			•	•	•	•	•	•

*See "Drip Zone Control Kits" on page 103.

ADVANCED FEATURES

FLOW CONTROL

Maximize efficiency and prolong the life of a system by fine tuning flow and pressure for each zone.

SRV, PGV, PGV-JT, PGV-ASV, ICV, IBV



RECLAIMED WATER ID HANDLE

Violet tags and handles are an option for a clear, quick, and simple method of identifying the use of non-potable water.

SRV, PGV, PGV-JT, PGV-ASV, ICV, IBV (tag)



FILTER SENTRY™

The Filter Sentry scours the filter clean with a wiper that slides up and covers the entire screen when the valve opens. Even more, the wiper continues to scrub the filter's upper part during valve operation. The Filter Sentry can be added after the valve is installed as well.

ICV, IBV



ACCU-SYNC™ CAPABLE

Avoid sprinkler over-pressure conditions and experience significant water savings with Hunter's new Accu-Sync pressure regulator.

SRV, PGV, PGV-JT, PGV-ASV, ICV, IBV



ACCU-SYNC™

ACCU-SYNC BRINGS FIXED OR ADJUSTABLE PRESSURE REGULATION SIMPLY TO ANY ZONE

Accu-Sync is a simple pressure regulator designed for all of Hunter's control valves. The adjustable model enables the zone pressure to be set anywhere between 20 and 100 PSI, while fixed models remove the guesswork and can be installed throughout any system easily. No matter which model you choose, all zones stay in tune with Accu-Sync.

OPERATING SPECIFICATIONS

Regulation from 20 to 100 PSI (2 to 8 bar; 200 to 800 kPa)
 Static pressure: 150 PSI (10 bar; 1000 kPa)
 Required dynamic pressure differential: 15 PSI (1 bar; 100 kPa)
 Works with AC and DC latching solenoids
 Works with any Hunter valve

Accu-Sync Valve Recommended Flow Ranges

Valve	Flow GPM
SRV-100/101	5 to 30
PGV-100/101	5 to 30
PGV-151	20 to 120
PGV-201	40 to 150
ICV-101	5 to 40
ICV-151	20 to 150
ICV-201	40 to 200
ICV-301	150 to 300
IBV-101	5 to 40
IBV-151	20 to 150
IBV-201	40 to 200
IBV-301	150 to 300

hunterindustries.com/ACCUSYNC

The Accu-Sync shown installed on the ICV valve.



ADJUSTABLE

AS-ADJ:
 Height with solenoid: 3¼"
 Length: 4½"



FIXED

AS-20:
 Height with solenoid: 3¼"
 Length: 4⅜"



AS-30:
 Height with solenoid: 3¼"
 Length: 4⅜"



AS-40:
 Height with solenoid: 3¼"
 Length: 4⅜"

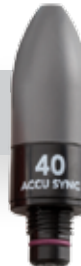

AS-50:
 Height with solenoid: 3¼"
 Length: 4⅜"



AS-70:
 Height with solenoid: 3¼"
 Length: 4⅜"



SRV

APPLICATION

Residential

SIZE

1"

FLOW RATE

1 to 30 GPM

WHERE DEPENDABILITY AND AFFORDABILITY ARE A QUESTION, SRV IS THE ANSWER.

FEATURES

- Application: Residential
- Size: 1"
- Double-beaded diaphragm seal design for superior leak-free performance
- DC latching solenoids enable Hunter's battery-powered controllers control of the valve
- Captive bonnet bolts provide hassle-free valve maintenance
- Low flow capability allows use of Hunter's micro-irrigation products
- Encapsulated 24 VAC solenoid with captive plunger for hassle-free service
- Temperature rating: 125° F
- Warranty period: 2 years

ADVANCED FEATURES

- Flow control (SRV101 only)
- Reclaimed water ID handle (SRV101 only)
- Accu-Sync™ capable
- = Detailed descriptions on pages 61 and 62

OPERATING SPECIFICATIONS

Flow rate: 1 to 30 GPM

Recommended pressure range: 20 to 150 PSI

24 VAC solenoid:

370 mA inrush, 190 mA holding, 60 cycles

475 mA inrush, 230 mA holding, 50 cycles

USER INSTALLED OPTIONS

Solenoid conduit cover (P/N 464322)

DC latching solenoid (P/N 458200)

Accu-Sync pressure regulator

Reclaimed water ID handle (P/N 269205)

SRV Pressure Loss in PSI

GPM	1" Globe
1	1.1
5	1.9
10	1.9
15	1.6
20	3.3
25	5
30	6.1

Charts based on full-open flow control position



SRV-100G:
Inlet Diameter: 1"
5" H x 4½" L x 2½" W

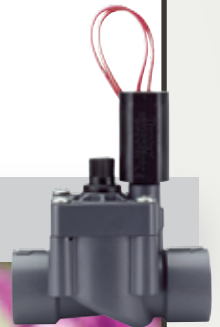

SRV-101G:
5" H x 4½" L x 2½" W

SPECIFICATIONBUILDER

hunterindustries.com/SRV

MODELS	INLET/OUTLET	OPTIONS USER INSTALLED
SRV-100G = 1" Globe valve, no flow control	(blank) = Female NPT S = Slip x slip B = BSP threads	(blank) = No option R = Reclaimed water ID handle (except SRV-100G) DC = DC latching solenoid CC = Solenoid conduit cover AS-ADJ = Accu-Sync adjustable pressure regulator AS-20 = Accu-Sync 20 PSI pressure regulator AS-30 = Accu-Sync 30 PSI pressure regulator AS-40 = Accu-Sync 40 PSI pressure regulator AS-50 = Accu-Sync 50 PSI pressure regulator AS-70 = Accu-Sync 70 PSI pressure regulator
SRV-101G = 1" Globe valve, with flow control		

EXAMPLES

SRV-100G - R	1" Globe valve, no flow control, with reclaimed water ID handle
SRV-101G	1" Globe valve, with flow control
SRV-100G - DC	1" Globe valve, no flow control, with DC latching solenoid
SRV-101G - S - R	1" Globe valve, with flow control, slip x slip, and reclaimed water ID handle

PGV

APPLICATION

Residential/Light Commercial

SIZE

1", 1½", 2"

FLOW RATE

0.2 to 150 GPM

THESE PROFESSIONAL GRADE VALVES ARE READY FOR ALL SYSTEM SIZES.

FEATURES

- Application (PGV100): Residential
- Application (PGV101, 151, 201): Residential/light commercial
- Sizes: 1", 1½", 2"
- External and internal manual bleed allows quick and easy "at the valve" activation
- Durable bolted bonnet design for maximum strength
- Double-beaded diaphragm seal design for superior leak-free performance
- DC latching solenoids enable Hunter's battery-powered controllers
- Captive bonnet bolts provide hassle-free valve maintenance
- Low flow capability allows use of Hunter's micro-irrigation products
- Encapsulated 24 VAC solenoid with captive plunger for hassle-free service
- Temperature rating: 150° F
- Warranty period: 2 years

ADVANCED FEATURES

- Flow control (PGV101, 151, and 201 only)
- Accu-Sync™ capable
- = Detailed descriptions on pages 61 and 62

OPERATING SPECIFICATIONS

1" flow rate: 0.2 to 30 GPM

1½" flow rate: 20 to 120 GPM

2" flow rate: 20 to 150 GPM

Recommended pressure range: 20 to 150 PSI

24 VAC solenoid:

370 mA inrush, 190 mA holding, 60 cycles

475 mA inrush, 230 mA holding, 50 cycles

FACTORY INSTALLED OPTIONS

Valve without solenoid

DC latching solenoid

USER INSTALLED OPTIONS

Solenoid conduit cover (P/N 464322)

DC latching solenoid (P/N 458200)

Accu-Sync pressure regulator

Reclaimed water ID handle for

PGV-101 models (P/N 269205) and

PGV-151/201 models (P/N 607105)

PGV Pressure Loss in PSI

GPM	1"		1½"		2"	
	Globe	Angle	Globe	Angle	Globe	Angle
1	1.1	1				
5	1.9	1				
10	1.9	1				
15	1.6	1				
20	3.3	2	3	3	1	1
30	6.1	3	3	3	1	2
40			3	3	2	2
50			4	3.5	1	1
60			5	4	2	2
80			5.5	4.5	3	2
100			9	8	5	3
120			11.5	10.5	6	5
135					8	7
150					10	9



PGV-100G:

Inlet Diameter: 1"
5" H x 4½" L x 2½" W



PGV-101G:

Inlet Diameter: 1"
5" H x 4½" L x 2½" W



PGV-151:

Inlet Diameter: 1.5"
7½" H x 5¾" L x 4½" W



PGV-201:

Inlet Diameter: 2"
8" H x 6¾" L x 5¼" W

SPECIFICATIONBUILDER

hunterindustries.com/PGV

MODELS	INLET/OUTLET	OPTIONS FACTORY INSTALLED	OPTIONS USER INSTALLED
PGV-100G = 1" Globe valve, no flow control	(blank) = Female NPT S = Slip x slip (excludes PGV-151 and PGV-201) B = BSP threads	(blank) = No option DC = DC latching solenoid LS = Valve without solenoid	(blank) = No options R = Reclaimed water ID handle (except PGV-100G) CC = Solenoid conduit cover DC = DC latching solenoid AS-ADJ = Accu-Sync adjustable pressure regulator AS-20 = Accu-Sync 20 PSI pressure regulator AS-30 = Accu-Sync 30 PSI pressure regulator AS-40 = Accu-Sync 40 PSI pressure regulator AS-50 = Accu-Sync 50 PSI pressure regulator AS-70 = Accu-Sync 70 PSI pressure regulator
PGV-101G = 1" Globe valve, with flow control			
PGV-100A = 1" Angle valve, no flow control			
PGV-101A = 1" Angle valve, with flow control			
PGV-151 = 1½" Globe/angle valve, with flow control			
PGV-201 = 2" Globe/angle valve, with flow control			
PGV-100 = 1" Globe valve, no flow control	MB = Male thread x 1" barb MB125 = Male thread x 1¼" barb MM = Male x male (NPT)		
PGV-101 = 1" Globe valve, with flow control			

EXAMPLES

PGV-101G - S - DC	1" Globe valve, with flow control, slip x slip, and DC latching solenoid
PGV-100 - MB - AS	1" Globe valve, no flow control, male thread x 1" barb, and Accu-Sync™ pressure regulator
PGV-151 - DC - R	1½" Globe/angle valve, with flow control, DC latching solenoid, and reclaimed water ID handle

PGV JAR-TOP

APPLICATION

Residential

SIZE

1"

FLOW RATE

0.2 to 30 GPM

THE JAR-TOP MAKES THIS GO-TO VALVE AN EASY CHOICE WITH SIMPLE SERVICEABILITY.

FEATURES

- Application: Residential
- Size: 1"
- External and internal manual bleed allows quick and easy "at the valve" activation
- Durable glass-filled nylon threaded bonnet ring allows easy access without tools
- Double-beaded diaphragm seal design for superior leak-free performance
- DC latching solenoids enable Hunter's battery-powered controllers
- Low flow capability allows use of Hunter's micro-irrigation products
- Encapsulated 24 VAC solenoid with captive plunger for hassle-free service
- Temperature rating: 150° F
- Warranty period: 2 years

ADVANCED FEATURES

- Flow control (PGV101 Jar-Top only)
- Reclaimed water ID handle (PGV101 Jar-Top only)
- Accu-Sync™ capable
- = Detailed descriptions on pages 61 and 62

OPERATING SPECIFICATIONS

Flow rate: 0.2 to 30 GPM
 Recommended pressure range: 20 to 150 PSI
 24 VAC solenoid:
 370 mA inrush, 190 mA holding, 60 cycles
 475 mA inrush, 230 mA holding, 50 cycles

FACTORY INSTALLED OPTIONS

Valve without solenoid
 DC latching solenoid

USER INSTALLED OPTIONS

Solenoid conduit cover (P/N 464322)
 DC latching solenoid (P/N 458200)
 Accu-Sync pressure regulator
 Reclaimed water ID handle (P/N 269205)

PGV Jar-Top Pressure Loss in PSI

GPM	1"
1	1.1
5	1.9
10	1.9
15	1.6
20	3.3
30	6.1

Charts based on full-open flow control position

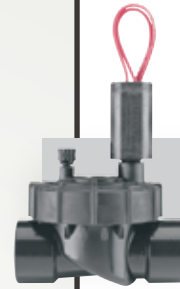

PGV-100JT - G:
 Inlet Diameter: 1"
 5½" H x 4½" L x 3¼" W

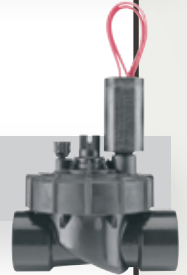

PGV-101JT - G:
 Inlet Diameter: 1"
 5½" H x 4½" L x 3¼" W



SPECIFICATIONBUILDER

hunterindustries.com/PGVJARTOP

MODELS	INLET/OUTLET	OPTIONS FACTORY INSTALLED	OPTIONS USER INSTALLED
PGV-100JT = 1" Globe jar-top valve, no flow control	G = Female NPT GS = Slip x slip GB = BSP threads MM = Male x male (NPT) MMB = Male x male (BSP) MB = Male x 1" barb MB075 = Male x ¾" barb MB125 = Male x ½" barb	(blank) = No option LS = Less solenoid (only available on 101JT - G, 100JT - G, 101JT - GB, 100JT - GB) DC = DC latching solenoid	(blank) = No option R = Reclaimed water ID handle CC = Solenoid conduit cover DC = DC latching solenoid AS-ADJ = Accu-Sync adjustable pressure regulator AS-20 = Accu-Sync 20 PSI pressure regulator AS-30 = Accu-Sync 30 PSI pressure regulator AS-40 = Accu-Sync 40 PSI pressure regulator AS-50 = Accu-Sync 50 PSI pressure regulator AS-70 = Accu-Sync 70 PSI pressure regulator
PGV-101JT = 1" Globe jar-top valve, with flow control			

EXAMPLES

PGV-101JT - G	1" Globe jar-top valve, with flow control, and female NPT
PGV-101JT - GS - R	1" Globe jar-top valve, with flow control, slip x slip, and reclaimed water ID handle
PGV-101JT - G - R	1" Globe jar-top valve, with flow control, female NPT, and reclaimed water ID handle
PGV-100JT - MB075 - DC	1" Globe jar-top valve, no flow control, with male x ¾" barb, and DC latching solenoid

VALVES

PGV-ASV

APPLICATION

Residential

SIZES

¾", 1"

FLOW RATE

0.2 to 30 GPM

PGV-ASV PROVIDES SIMPLE AND TROUBLE-FREE OPERATION WITHOUT THE NEED FOR A SEPARATE BACKFLOW PREVENTER.

FEATURES

- Application: Residential
- Sizes: ¾", 1"
- External and internal manual bleed allows quick and easy "at the valve" activation
- Durable six-bolt bonnet design for maximum strength
- Removable anti-siphon cap for simple servicing
- Double-beaded diaphragm seal design for superior leak-free performance
- DC latching solenoids enable Hunter's battery-powered controllers
- Captive bonnet bolts provide hassle-free valve maintenance
- Low flow capability allows use of Hunter's micro irrigation products
- Encapsulated 24 VAC solenoid with captive plunger for hassle-free service
- Temperature rating: 150° F
- Warranty period: 2 years

ADVANCED FEATURES

- Flow control
- Reclaimed water ID handle
- Accu-Sync™ capable
- = Detailed descriptions on pages 61 and 62

OPERATING SPECIFICATIONS

Flow rate: 0.2 to 30 GPM

Recommended pressure range: 20 to 150 PSI

24 VAC solenoid:

370 mA inrush, 190 mA holding, 60 cycles

475 mA inrush, 230 mA holding, 50 cycles

FACTORY INSTALLED OPTIONS

Valve without solenoid

USER INSTALLED OPTIONS

Solenoid conduit cover (P/N 464322)

DC latching solenoid (P/N 458200)

Accu-Sync™ pressure regulator

Reclaimed water ID handle (P/N 269205)

AVB Pressure Loss in PSI

GPM	1"
1	<1
5	<1
10	1.2
15	2.2
20	3.6
25	5.2
30	7

PGV-ASV Pressure Loss in PSI

GPM	¾"	1"
1	1	1
5	2	2
10	2	2
15	3	3
20	6	6
25		6
30		9

Charts based on full-open flow control position



PGV-075-ASV:

Inlet Diameter: ¾"
5½" H x 5¾" L x 2½" W

PGV-101-ASV:

Inlet Diameter: 1"
5½" H x 6¼" L x 2½" W

SPECIFICATIONBUILDER

hunterindustries.com/PGVASV

MODELS	INLET/OUTLET	OPTIONS FACTORY INSTALLED	OPTIONS USER INSTALLED
PGV-075 = ¾" Anti-siphon valves with flow control	ASV = Female NPT ASV-S = Slip x slip	LS = Valve without solenoid	(blank) = No option R = Reclaimed water ID handle DC = DC latching solenoid CC = Solenoid conduit cover AS-ADJ = Accu-Sync adjustable pressure regulator AS-20 = Accu-Sync 20 PSI pressure regulator AS-30 = Accu-Sync 30 PSI pressure regulator AS-40 = Accu-Sync 40 PSI pressure regulator AS-50 = Accu-Sync 50 PSI pressure regulator AS-70 = Accu-Sync 70 PSI pressure regulator
PGV-101 = 1" Anti-siphon valves with flow control			

EXAMPLES

PGV-075 - ASV	¾" Anti-siphon valves with flow control, and female NPT
PGV-101 - ASV-S - DC	1" Anti-siphon valves with flow control, slip x slip, and DC latching solenoid
PGV-101 - ASV - R	1" Anti-siphon valves with flow control, female NPT, and reclaimed water ID handle

MODEL

AVB-100 = 1" Atmospheric vacuum breaker/female NPT

AVB-100



APPLICATION: Commercial/Municipal
 SIZES: 1", 1½", 2", 3"
 FLOW RATE: 0.1 to 300 GPM

ICV IS ONE VALVE READY TO TAKE ON ANY COMMERCIAL HIGH-PRESSURE SYSTEM.

FEATURES

- Application: Commercial/municipal
- Sizes: 1", 1½", 2", 3"
- External and internal manual bleed allows quick and easy "at the valve" activation
- Glass-filled nylon construction resulting in the highest pressure rating
- Double-beaded diaphragm seal design for superior leak-free performance
- Fabric reinforced EPDM diaphragm and EPDM seat ensure superior performance in all conditions
- DC latching solenoids enable Hunter's battery-powered controllers
- Captive bonnet bolts provide hassle-free valve maintenance
- Low flow capability allows use Hunter's micro-irrigation products
- Encapsulated 24 VAC solenoid with captive plunger for hassle-free service
- Temperature rating: 150° F
- Warranty period: 5 years

ADVANCED FEATURES

- Flow control
- Filter Sentry™
- = Detailed descriptions on pages 61 and 62

OPERATING SPECS

- 1" Flow rate: 0.1 to 40 GPM
- 1½" Flow rate: 20 to 135 GPM
- 2" Flow rate: 40 to 150 GPM
- 3" Flow rate: 150 to 300 GPM

Recommended pressure range: 20 to 220 PSI
 24 VAC solenoid:
 370 mA inrush, 190 mA holding, 60 cycles
 475 mA inrush, 230 mA holding, 50 cycles

FACTORY INSTALLED OPTIONS

- DC latching solenoid
- Filter Sentry

USER INSTALLED OPTIONS

- Solenoid conduit cover (P/N 464322)
- DC latching solenoid (P/N 458200)
- Accu-Sync pressure regulator
- Reclaimed water ID handle for ICV101, 151, and 201 (P/N 561205) and 301 (P/N 515005)
- Reclaimed water ID tag for all ICV valves P/N 700392



ICV Pressure Loss in PSI					ICV Pressure Loss in PSI					ICV Pressure Loss in PSI				
3"					3"					3"				
GPM	1"	1½"	2"	Globe Angle	GPM	1"	1½"	2"	Globe Angle	GPM	1"	1½"	2"	Globe Angle
0.1	2				40	7	1.7	0.8		150		16.2	9.8	2.5
0.5	2				50		2.2	1.2		175			13.3	3
1	2				60		3	1.7		200			17.7	4.1
5	2.5				75		3.9	2.4		225				5.3
10	3				90		5.5	3.2		250				6.7
15	3				100		7	4.2		275				8.3
20	3	1.5			120		10.9	6.5		300				10.1
30	4	1.5			135		12.7	7.9		Charts based on full-open flow control position				

SPECIFICATIONBUILDER

hunterindustries.com/ICV

MODELS	INLET/OUTLET	OPTIONS FACTORY INSTALLED	OPTIONS USER INSTALLED
ICV-101G = 1" globe valve	(blank) = NPT threads B = BSP threads	(blank) = No option FS = Filter Sentry DC = DC latching solenoid	(blank) = No option R = Reclaimed water ID tag CC = Solenoid conduit cover DC = DC latching solenoid AS-ADJ = Accu-Sync adjustable pressure regulator AS-20 = Accu-Sync 20 PSI pressure regulator AS-30 = Accu-Sync 30 PSI pressure regulator AS-40 = Accu-Sync 40 PSI pressure regulator AS-50 = Accu-Sync 50 PSI pressure regulator AS-70 = Accu-Sync 70 PSI pressure regulator
ICV-151G = 1½" globe valve			
ICV-201G = 2" globe valve			
ICV-301 = 3" globe/angle valve			

EXAMPLES

ICV-101G	1" globe valve, NPT threads
ICV-151G - FS - R	1½" globe valve, NPT threads, Filter Sentry, and reclaimed water ID tag

VALVES

IBV

APPLICATION
Commercial/MunicipalSIZES
1", 1½", 2", 3"FLOW RATE
0.1 to 300 GPM

THE HIGH-END IBV BRASS VALVE WAS DESIGNED FOR THE RIGORS OF A COMMERCIAL SITE.

FEATURES

- Application: Commercial/municipal
- Sizes: 1", 1½", 2", 3"
- External and internal manual bleed allows quick and easy "at the valve" activation
- Double-beaded diaphragm seal design for superior leak-free performance
- Fabric reinforced EPDM diaphragm and EPDM seat ensure superior performance in all conditions
- DC latching solenoids enable Hunter's battery-powered controllers
- Captive bonnet bolts providing hassle-free valve maintenance
- Low flow capability allows use of Hunter's micro irrigation products
- Encapsulated 24 VAC solenoid with captive plunger for hassle-free service
- Temperature rating: 150° F
- Warranty period: 5 years

ADVANCED FEATURES

- Flow control
- Filter Sentry™
- Accu-Sync™ capable
- = Detailed descriptions on pages 61 and 62

OPERATING SPECS

1" Flow rate: 0.1 to 40 GPM

1½" Flow rate: 20 to 135 GPM

2" Flow rate: 40 to 150 GPM

3" Flow rate: 150 to 300 GPM

Recommended pressure range: 20 to 220 PSI

24 VAC solenoid:

370 mA inrush, 190 mA holding, 60 cycles

475 mA inrush, 230 mA holding, 50 cycles

FACTORY INSTALLED OPTIONS

Valve without solenoid

DC latching solenoid

Filter Sentry

USER INSTALLED OPTIONS

Solenoid conduit cover (P/N 464322)

DC latching solenoid (P/N 45800)

Accu-Sync pressure regulator

Reclaimed water ID tag P/N 700392

IBV Pressure Loss in PSI

GPM	1"	1½"	2"	3"
0.1	2			
0.5	2			
1	2			
5	2.5			
10	3			
15	3			
20	3	1.5		
30	4	1.5		
40	7	1.7	0.8	
50		2.2	1.2	
60		3	1.7	
75		3.9	2.4	
90		5.5	3.2	
100		7	4.2	
120		10.9	6.5	
135		12.7	7.9	
150		16.2	9.8	2.5
175			13.3	3
200			17.7	4.1
225				5.3
250				6.7
275				8.3
300				10.1

Charts based on full-open flow control position

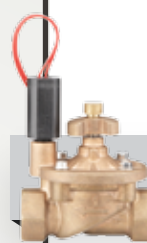

IBV-101G:
4½" H x 3¾" L x 5¼" W

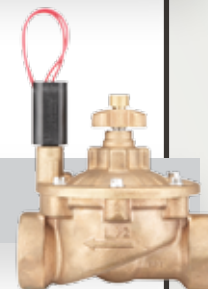

IBV-151G:
6¼" H x 5¼" L x 6 ½" W



IBV-201G:
6 ⅞" H x 5¼" L x 6 ⅞" W

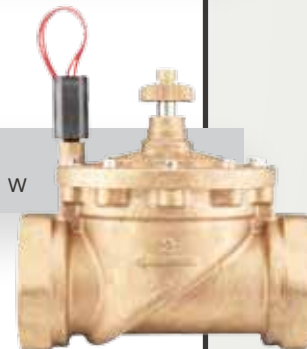

IBV-301G:
9 ⅞" H x 7¼" L x 9 ⅞" W

VALVES

SPECIFICATION BUILDER

hunterindustries.com/IBV

MODELS	INLET/OUTLET	OPTIONS FACTORY INSTALLED	OPTIONS USER INSTALLED
IBV-101G = 1" globe valve	(blank) = NPT threads B = BSP threads	(blank) = No option FS = Filter Sentry DC = DC latching solenoid	(blank) = No option R = Reclaimed water ID tag CC = Solenoid conduit cover DC = DC latching solenoid AS-ADJ = Accu-Sync adjustable pressure regulator AS-20 = Accu-Sync 20 PSI pressure regulator AS-30 = Accu-Sync 30 PSI pressure regulator AS-40 = Accu-Sync 40 PSI pressure regulator AS-50 = Accu-Sync 50 PSI pressure regulator AS-70 = Accu-Sync 70 PSI pressure regulator
IBV-151G = 1½" globe valve			
IBV-201G = 2" globe valve			
IBV-301G = 3" globe valve			

EXAMPLES

IBV-101G	1" globe valve
IBV-151G - FS - R	1½" globe valve, NPT threads, Filter Sentry, and reclaimed water ID tag

QUICK COUPLERS

APPLICATION
Commercial

QUICK COUPLERS WITH ULTRA STURDY RED BRASS AND STAINLESS STEEL CONSTRUCTION ADD VALUE TO ANY PROJECT.

FEATURES

- 100% Interchangeable with Rain Bird®, Toro®, and Buckner®
- Red brass and stainless steel construction
- TuffTop™ thermoplastic locking and non-locking covers
- Optional WingThing™ stabilization and acme key connection
- Stainless steel lug on 1" and 1¼" keys
- Spring-loaded covers with stainless steel springs for positive closing and protection of valve's sealing components

See page 112 for replacement guide



MODEL	INLET THREADS	SLOTS	BODY	COLOR *	LOCKING	KEY	SWIVELS
HQ-3RC	3/4" NPT	2	1 - Piece	Yellow	No	HK-33	HS-0
HQ-33DRC	3/4" NPT	2	2 - Piece	Yellow	No	HK-33	HS-0
HQ-33DLRC	3/4" NPT	2	2 - Piece	Yellow	Yes	HK-33	HS-0
HQ-44RC	1" NPT	1	2 - Piece	Yellow	No	HK-44	HS-1 or HS-2
HQ-44LRC	1" NPT	1	2 - Piece	Yellow	Yes	HK-44	HS-1 or HS-2
HQ-44RC-AW	1" NPT	Acme	2 - Piece Wing†	Yellow	No	HK-44A	HS-1 or HS-2
HQ-44LRC-AW	1" NPT	Acme	2 - Piece Wing†	Yellow	Yes	HK-44A	HS-1 or HS-2
HQ-5RC	1" NPT	2	1 - Piece	Yellow	No	HK-55	HS-1 or HS-2
HQ-5LRC	1" NPT	2	1 - Piece	Yellow	Yes	HK-55	HS-1 or HS-2
HQ-5RC-B	1" BSP	2	1 - Piece	Yellow	No	HK-55	HS-1-B or HS-2-B
HQ-5LRC-B	1" BSP	2	1 - Piece	Yellow	Yes	HK-55	HS-1-B or HS-2-B

* All locking cover models are available with purple covers for reclaimed water applications.
† Anti-rotation stabilization wings.

SPECIFICATIONBUILDER

hunterindustries.com/HQ

HQ - VALVE MODELS	COVER OPTIONS	ADDITIONAL OPTIONS
HQ3 = ¾" Inlet, 1-piece body, 2 slots	RC = Yellow rubber cover LRC = Yellow locking rubber cover (Not available for the HQ3 body)	(blank) = No option AW = Acme key with anti-rotation wings* BSP = BSP threads † R = Purple locking cover (reclaimed water ID) ‡
HQ5 = 1" Inlet, 1-piece body, 2 slots		
HQ33D = ¾" Inlet, 2-piece body, 2 slots		
HQ44 = 1" Inlet, 2-piece body, 1 slot or acme		

EXAMPLES

HQ3 - RC	HQ3 valve with rubber cover
HQ44 - LRC	HQ44 valve with locking rubber cover
HQ44 - LRC - R	HQ44 valve with locking rubber cover and reclaimed water ID
HQ44 - LRC - AW - R	HQ valve, locking rubber cover, acme key socket, anti-rotation wings and reclaimed ID
HQ5 - LRC - BSP	HQ5 valve with locking rubber cover and BSP body inlet threads

* only available in body HQ44 † only available in body HQ5 ‡ only available LRC models



All locking models have an optional purple TuffTop™ cover for sites using reclaimed water.

HK - KEY MODELS	COMPATIBLE VALVE	COMPATIBLE SWIVEL
HK33 = ¾" valve, ¾" key inlet	HQ3, HQ33	HS0
HK44 = 1" valve, 1" key inlet	HQ44	HS1, HS2, HS1B, HS2B
HK44A = 1" valve, acme key inlet	HQ44AW	HS1, HS2, HS1B, HS2B
HK55 = 1" valve, 1¼" key inlet	HQ5	HS1, HS2, HS1B, HS2B

EXAMPLE

HK-44

HOSE SWIVELS	COMPATIBLE KEY
HS0 = ¾" inlet, ¾" hose outlet	HK33
HS1 = 1" inlet, ¾" hose outlet	HK44, HK44A, HK55
HS2 = 1" inlet, 1" hose outlet	HK44, HK44A, HK55
HS1B = 1" inlet, ¾" BSP outlet	HK44, HK44A, HK55
HS2B = 1" inlet, 1" BSP outlet	HK44, HK44A, HK55

EXAMPLE

HS-1

VALVES

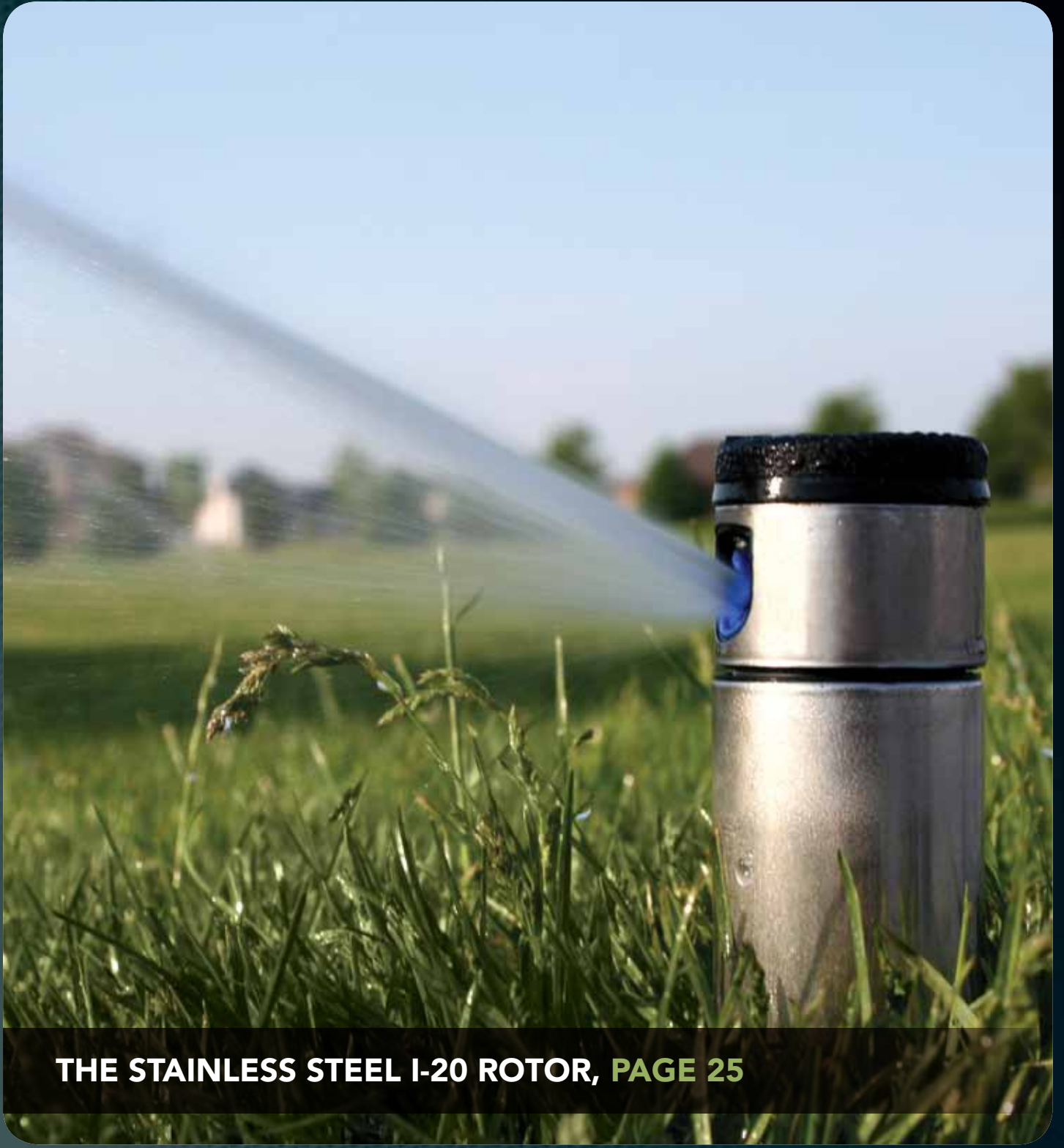

THE STAINLESS STEEL I-20 ROTOR, PAGE 25



TAKE COMMAND. Even the best system will fall short without the brains to back it up. With a Hunter controller at the helm, smart irrigation becomes simple irrigation with user-friendly operation, water-conserving features, and optional modularity.

CONTROLLERS

COMPARISON CHART

							Battery-Powered Controllers		
	ELC	X-CORE	PCC	PRO-C	I-CORE	ACC	XC HYBRID	NODE	WVS
APPLICATIONS									
Residential	•	•	•	•			•	•	•
Light commercial			•	•			•	•	•
Commercial					•		•	•	•
High-end commercial						•	•	•	•
TYPE									
Fixed	•	•	•				•	•	•
Modular				•	•	•			
Decoder					•	•			
Indoor	•	•	•	•					
Outdoor		•	•	•	•	•	•	•	•
FEATURES									
Number of stations	4, 6	2, 4, 6, 8	6, 9, 12, 15	3 to 15	6 to 42 [†] 1 to 48 [‡]	12 to 42 [†] 1 to 99 [‡]	4, 6, 8, 10, 12	1, 2, 4, 6	1, 2, 4
Independent programs	3	3	3	3	4	6	3	3	Program by station
Start times per program	4	4	4	4	8 (A, B, C) 16 (D)	10	4	4	9
Max. station run time (hrs)	4	4	6	6	12	6	4	6	4

[†] Conventional controller

[‡] Decoder controller

ADVANCED FEATURES

AUTOMATIC SHORT CIRCUIT PROTECTION

Automatic short circuit protection, found in all Hunter AC powered controllers, automatically detects electrical faults typically caused by wiring issues or damage. Shorted stations are skipped, allowing watering to continue for those stations that are not faulty. No fuses to blow or internal circuit breakers to trip that can result in completely disabling irrigation.

X-CORE, PCC, PRO-C, I-CORE, ACC

CYCLE AND SOAK

Water-saving feature that allows the operator to specify a maximum run time for each single station, followed by a minimum soak time, to prevent runoff from slopes or saturated soil. The operator can enter any run time, and the controller will automatically divide it into cycles to allow the water to be absorbed during the soak periods. The feature is adjustable by individual station for unique soil and site conditions.

I-CORE, ACC

DELAY BETWEEN STATIONS

A delay in watering between individual stations as the controller steps sequentially through zones of irrigation. The delay may range from a few seconds, to permit slow-closing valves time to shut down, or much longer to allow pressure tanks, etc., to refill or recharge.

X-CORE, PCC, PRO-C, I-CORE, ACC

SEASONAL ADJUSTMENT

This feature allows for quick adjustments to irrigation run times through a percentage scale. During peak season, set the seasonal adjust to 100%. If weather conditions require less water, enter the appropriate percentage value (i.e. 50%) to cut down irrigation run times without the need to adjust each station in the program. Hunter offers three different ways to use Seasonal Adjustment to reduce water usage:

Globally: Provides a seasonal adjustment value to all controller programs (available on most Hunter controllers)

Monthly: Allows user to program seasonal adjustment values for each month of the year (available on I-Core controller). The controller will automatically change the programmed seasonal adjustment value at the first day of every month.

Daily (Solar Sync ET sensor): Implements an automatic daily adjustment based on measured local weather (available for most Hunter controllers)

X-CORE, PCC, PRO-C, I-CORE, ACC, XC HYBRID, NODE

EASY RETRIEVE™

A manual back-up utility that stores a complete controller's schedule and setup information in back-up memory. This allows the saved watering schedule to be restored at any time. This can be used to set a controller back to the initial settings after tampering or at the beginning of a new season.

X-CORE, PCC, PRO-C, I-CORE, ACC, XC HYBRID, NODE

EVENT DAY OFF PROGRAMMING

Day(s) of the week can be programmed Off in advance, so that irrigation does not occur regardless of program interval schedules. For example, if the gardener mows the lawn on Saturday, the Event Day Off feature allows Saturday to be programmed Off, so that watering will not occur.

PCC, PRO-C, I-CORE, ACC

NO WATER WINDOW

User-specified periods of time during which the controller will not allow automatic irrigation. No Water Window can be used to comply with local watering restrictions or to prevent conflicts with pedestrian traffic. This setting does not affect manual watering options for local maintenance.

I-CORE, ACC

PROGRAMMABLE RAIN DELAY

A user-specified number of days for the controller to remain in Off mode, but then automatically revert to automatic irrigation. This will prevent watering during an extended period of inclement weather, but will resume watering automatically without requiring a return visit to the controller. The controller displays the number of days remaining before watering resumes.

X-CORE, PCC, PRO-C, I-CORE, ACC, XC HYBRID, NODE

QUICK CHECK™

This feature allows for the quick diagnosis of wiring problems to valves in the field instead of checking each field wiring circuit for potential problems. Quick Check can detect a field wiring short and displays an "ERR" and station number on the display.

X-CORE, PCC, PRO-C, I-CORE, ACC, NODE

REAL TIME FLOW MONITORING

This feature permits connection of a flow meter to recognize high or low flow conditions and react automatically to alarms. The controller learns typical flows for each zone of irrigation and then monitors performance during automatic irrigation. When incorrect flows are detected, the controller can identify the faulty station and shut it down. Used with a normally-closed Master Valve. Alarm parameters are user-programmable. Flow totals are also recorded in controller memory to verify system water usage.

I-CORE, ACC

SENSOR PROGRAMMABILITY

The ability to specify which program or stations will be shut down in response to a specific sensor alarm. This allows stations or programs unaffected by the sensor to continue automatic operations.

X-CORE, PCC, PRO-C, I-CORE, ACC, XC HYBRID

SIMULTANEOUS STATION GROUPS

The ability to group stations into larger irrigation units that run together within automatic programs. This permits consolidation of large systems into fewer items to program and can be used to control system flow in high capacity installations.

ACC

TOTAL RUN TIME CALCULATOR

This feature adds up all run times, and calculates the total duration of a program or to instantly display the full length of an irrigation cycle. This information can be used to determine the time of day at which watering will end.

PCC, PRO-C, I-CORE, ACC, NODE

NON-VOLATILE MEMORY

This feature offers protection against unreliable power, retaining current time, day, and program data.

X-CORE, PCC, PRO-C, I-CORE, ACC, XC HYBRID, NODE

X-CORE

APPLICATION

NUMBER OF STATIONS

TYPE

Residential

2, 4, 6, 8

Fixed

THIS ENTRY-LEVEL CONTROLLER NOW GETS SMART WITH THE OPTIONAL SOLAR SYNC.

FEATURES

- Number of stations: 2, 4, 6, 8
- Type: Fixed
- Enclosures: Indoor and outdoor
- Independent programs: 3
- Start times per program: 4
- Max. station run time: 4 hrs
- Warranty period: 2 years

ADVANCED FEATURES

- Easy Retrieve™ memory
- Compatible with Hunter Klik sensors and other micro-switch type weather sensors
- One touch manual start and advance for easy manual operation
- Rain sensor bypass
- Programmable rain delay: 1 to 7 days
- Test program allows for quick system checks
- Manual cycle
- Quick Check™
- = Detailed descriptions on pages 73 and 74
- Non-volatile memory
- Automatic short circuit protection
- Seasonal adjustment (global): 10% to 150% (in 10% increments)
- Delay between stations (maximum): 4 hrs
- Sensor programmable by zone
- Remote control operation with Hunter ROAM and ICR remotes
- Automatic daily weather-based scheduling with optional Hunter Solar Sync sensor

ELECTRICAL SPECIFICATIONS

Transformer input: 120 VAC or 230/240 VAC (international model)
 Transformer output (24 VAC): 1 A
 Station output (24 VAC): 0.56 A
 P/MV output (24 VAC): 0.56 A

Simultaneous station operation (includes master valve): 3 valves
 Pump/master valve
 Sensor inputs: 1
 Operating temperature: 0° F to 140° F

APPROVALS

CE, UL, cUL, C-tick, FCC
 IP24 (outdoor model)



Plastic indoor:
6½" H x 5¾" W x 2" D



Plastic outdoor:
8¾" H x 7" W x 3¾" D

SPECIFICATIONBUILDER

hunterindustries.com/XCORE

MODELS	TRANSFORMER	INDOOR/OUTDOOR	OPTIONS
XC-2 = 2 Stations (indoor model only)	00 = 120 VAC 01 = 230/240 VAC	(blank) = Outdoor model i = Indoor model	(blank) = No option E = 230/240 VAC with European connections A = 230/240 VAC with Australian connections (outdoor model has internal transformer with cord)
XC-4 = 4 Stations			
XC-6 = 6 Stations			
XC-8 = 8 Stations			

EXAMPLES

XC-200i	2-Station 120 VAC indoor controller, with plastic cabinet
XC-400	4-Station 120 VAC outdoor controller, with plastic cabinet
XC-600i	6-Station 120 VAC indoor controller, with plastic cabinet
XC-800	8-Station 120 VAC outdoor controller, with plastic cabinet

PCC

APPLICATION

Residential/Light Commercial

NUMBER OF STATIONS

6, 9, 12, 15

TYPE

Fixed

THE PRO-C CONVENTIONAL'S FIXED-STATION CONTROL IS A COST-EFFECTIVE CHOICE.

FEATURES

- Number of stations: 6, 9, 12, 15
- Type: Fixed
- Enclosures: Indoor and outdoor
- Independent programs: 3
- Start times per program: 4
- Max. station run time: 6 hrs
- Warranty period: 2 years

ADVANCED FEATURES

- Easy Retrieve™ memory
- Compatible with Hunter Klik sensors and other micro-switch type weather sensors
- One touch manual start and advance for easy manual operation
- Rain sensor bypass
- Programmable rain delay: 1 to 7 days
- Manual cycle
- Test program allows for quick system checks
- Quick Check™
- Non-volatile memory
- Automatic short circuit protection
- = Detailed descriptions on pages 73 and 74
- Seasonal adjustment (global): 5% to 300% (in 5% increments)
- Delay between stations (maximum): 4 hrs
- Sensor programmable by zone
- Total run time calculator
- Event day off programming
- Central control compatible with Hunter IMMST™
- Remote control operation with Hunter ROAM and ICR remotes
- Automatic daily weather-based scheduling with optional Hunter Solar Sync sensor or ET system

ELECTRICAL SPECIFICATIONS

Transformer input: 120 VAC or 230/240 VAC (international model)
 Transformer output (24 VAC): 1 A
 Station output (24 VAC): 0.56 A
 P/MV output (24 VAC): 0.56 A

Simultaneous station operation (includes master valve): 3 valves
 Pump/master valve
 Sensor inputs: 1
 Operating temperature: 0° F to 140° F

APPROVALS

CE, UL, cUL, C-tick, FCC
 IP54 (outdoor model)



Plastic indoor:
 8¼" H x 9½" W x 3¾" D



Plastic outdoor:
 9" H x 10" W x 4½" D

CONTROLLERS

SPECIFICATIONBUILDER

hunterindustries.com/PCC

MODELS	TRANSFORMER	INDOOR/ OUTDOOR	OPTIONS
PCC-6 = 6 Stations	00 = 120 VAC 01 = 230/240 VAC	(blank) = Outdoor model i = Indoor model	(blank) = No option SOL = Solar Sync™ E = 230/240 VAC with European connections A = 230/240 VAC with Australian connections (outdoor model has internal transformer with cord)
PCC-9 = 9 Stations			
PCC-12 = 12 Stations			
PCC-15 = 15 Stations			

EXAMPLES

PCC-1200i - A	12-Station indoor controller 230/240 VAC and plastic cabinet
PCC-600	6-Station outdoor controller 120 VAC and plastic cabinet
PCC-901i - E	9-Station indoor controller 230/240 VAC and plastic cabinet
PCC-900 - SOL	9-Station outdoor controller 120 VAC with Solar Sync
PCC-900i - SOL	9-Station indoor controller 120 VAC with Solar Sync

PRO-C

APPLICATION
Residential/Light Commercial

NUMBER OF STATIONS
3 to 15

TYPE
Modular

MODULARITY MEANS COMPLETE CUSTOMIZATION FROM 3 TO 15 STATIONS.

FEATURES

- Number of stations: 3 to 15
- Type: Modular
- Enclosures: Indoor and outdoor
- Independent programs: 3
- Start times per program: 4
- Max. station run time: 6 hrs
- Warranty period: 2 years

ADVANCED FEATURES

- Easy Retrieve™ memory
 - Compatible with Hunter Klik sensors and other micro-switch type weather sensors
 - One touch manual start and advance for easy manual operation
 - Rain sensor bypass
 - Programmable rain delay: 1 to 7 days
 - Manual cycle
 - Test program allows for quick system checks
 - Quick Check™
 - Non-volatile memory
 - Automatic short circuit protection
 - Seasonal adjustment (global): 5% to 300% (in 5% increments)
 - Delay between stations (maximum): 4 hrs
 - Sensor programmable by zone
 - Total run time calculator
 - Event day off programming
 - Central control compatible with Hunter IMMS™
 - Remote control operation with Hunter ROAM and ICR remotes
 - Automatic daily weather-based scheduling with optional Hunter Solar Sync sensor or ET system
- = Detailed descriptions on pages 73 and 74

ELECTRICAL SPECIFICATIONS

Transformer input: 120 VAC or 230/240 VAC (international model)
 Transformer output (24 VAC): 1 A
 Station output (24 VAC): 0.56 A
 P/MV output (24 VAC): 0.56 A

Simultaneous station operation (includes master valve): 3 valves
 Pump/master valve
 Sensor inputs: 1
 Operating temperature: 0° F to 140° F

APPROVALS

CE, UL, cUL, C-tick, FCC IP54 (outdoor model)



Plastic indoor:
8¼" H x 9½" W x 3¾" D



Plastic outdoor:
9" H x 10" W x 4½" D

SPECIFICATIONBUILDER

hunterindustries.com/PROC

BASE MODELS	OPTIONS
PC-300i = 3-Station indoor Pro-C controller, plug-in transformer	(blank) = No option
PC-300 = 3-Station outdoor Pro-C controller, internal transformer	
PC-301i = International version 3-Station indoor Pro-C controller, plug-in transformer	E = 230/240 VAC with European connections A = 230/240 VAC with Australian connections (outdoor model has internal transformer with cord)
PC-301 = International version 3-Station outdoor Pro-C controller, internal transformer	

STATION EXPANSION MODULES

PCM-300 = 3-Station plug-in module: Use to increase station count from 3 to 6, 6 to 9, and 9 to 12
 PCM-900 = 3-Station plug-in module: Use to increase station count from 6 to 15 only



EXAMPLES

PC-300i	3-Station indoor base unit, and plastic cabinet
PC-600i	3-Station indoor base unit, one PCM-300 module, and plastic cabinet
PC-900i	3-Station indoor base unit, two PCM-300 modules, and plastic cabinet
PC-1200	3-Station outdoor base unit, three PCM-300 modules, and plastic cabinet
PC-1500	3-Station outdoor base unit, one PCM-300 module, one PCM-900 module, and plastic cabinet
PC-601i - E	3-Station indoor base unit, one PCM-300 module, 230/240 VAC, and plastic cabinet

I-CORE

APPLICATION

Commercial

NUMBER OF STATIONS

6 to 42

TYPE

Modular

THE NEXT GENERATION OF COMMERCIAL CONTROL.

FEATURES

- Number of stations: 6 to 42
- Type: Modular
- Enclosure: Outdoor
- Independent programs: 4
- Start times per program: 8 (A, B, C); 16 (D)
- Max. station run time: 12 hrs
- Warranty period: 5 years

ADVANCED FEATURES

- Easy Retrieve™ memory
- Compatible with Hunter Klik sensors and other micro-switch type weather sensors
- One touch manual start and advance for easy manual operation
- Rain sensor bypass
- Programmable rain delay
- Manual cycle
- Test program allows for quick system checks
- Quick Check™
- Non-volatile memory
- Automatic short circuit protection
- Seasonal adjustment (global): 0% to 300% (in 1% increments)
- Seasonal adjustment (monthly)
- Delay between stations (maximum): 9 hrs
- Sensor programmable by zone
- Simultaneous program operation: Any 2
- = Detailed descriptions on pages 73 and 74
- Total run time calculator
- Cycle and Soak
- No water window
- Event day off programming
- Backlit display makes it easy to program in low light applications
- Real time flow monitoring
- Factory installed SmartPort®
- Multiple language programming (English, Spanish, French, Italian, German, Portuguese)
- Remote control operation with Hunter ROAM and ICR remotes
- Automatic daily weather-based scheduling with optional Hunter Solar Sync sensor

ELECTRICAL SPECIFICATIONS

Transformer input: 120/240 VAC, 50/60 Hz
 Transformer output (24 VAC): 1.4 A
 Dual voltage transformer (120/240 VAC)
 Station output (24 VAC): 0.56 A
 P/MV output (24 VAC): 0.56 A
 Simultaneous station operation (includes master valve): 5 valves
 Pump/master valve: 1, normally closed
 Sensor inputs: Plastic: 2; metal: 3
 Operating temperature: 0° F to 140° F

APPROVALS

CE, UL, cUL, C-tick, FCC
 Enclosure rating (plastic & metal): IP44

ALL STAINLESS STEEL (SS) MODELS

American-made Type 304 Stainless Steel
 .057" gauge steel
 Passivated for corrosion resistance



Plastic outdoor:
11" H x 13¼" W x 4¾" D



Metal wall mount (gray or stainless):
12¾" H x 15½" W x 6¾" D



Plastic pedestal:
38¾" H x 21⅞" W x 15⅞" D



Metal pedestal (gray or stainless):
36" H x 15.5" W x 5" D

CONTROLLERS

SPECIFICATIONBUILDER

hunterindustries.com/ICORE

BASE MODELS

IC-600-PL = 6-Station controller, indoor/outdoor, plastic cabinet
IC-601-PL = International version, 6-Station controller, indoor/outdoor, plastic cabinet
IC-600-M = 6-Station controller, indoor/outdoor, metal cabinet
IC-600-PP = 6-Station controller, indoor/outdoor, plastic pedestal
IC-600-SS = 6-Station controller, indoor/outdoor, stainless steel cabinet
ACC-PED = Metal pedestal, gray powder-coated, for use with I-Core and ACC metal controllers
PED-SS = Stainless pedestal for use with I-core and ACC stainless controllers

STATION EXPANSION MODULES

ICM-600 = 6-Station plug-in module used to increase station count by 6.
Plastic cabinet = Expands to 30 stations
Metal/stainless cabinet = Expands to 42 stations
Plastic pedestal = Expands to 42 stations
Stainless cabinet = Expands to 42 stations



EXAMPLES

IC-600-PL	6-Station base unit with plastic cabinet	IC-3000-PP	6-Station base unit, with plastic pedestal, and four ICM-600 modules
IC-1800-PL	6-Station base unit, with plastic cabinet, and two ICM-600 modules	IC-3600-M	6-Station base unit, with metal cabinet, and five ICM-600 modules
		IC-4200-M	6-Station base unit, with metal cabinet, and six ICM-600 modules
		IC-4200-SS	6-Station base unit, with stainless steel cabinet and six ICM-600 modules

I-Core's unique "bridge" modules activate the existing terminal strips.

DUAL

APPLICATION

Commercial

NUMBER OF STATIONS

6 to 48

TYPE

Decoder

USE DUAL TO CONVERT THE I-CORE TO A CUTTING EDGE TWO-WIRE CONTROLLER.

MODULE AND DECODER FEATURES

- Decoder station sizes available: 1, 2
- Max. distance to decoder, 14 AWG wire path: 5,000 ft; 12 AWG wire path 7,500 ft.
- Max. recommended distance, decoder to solenoid: 100 ft
- Field programmable decoders
 - DUAL decoder module display and push button programming makes it easy to program decoders at the controller itself
 - DUAL decoders can be field programmed with the Hunter ICD-HP. No need to remove decoders from the two-wire path.
- Decoder module displays decoder operation and diagnostic information
- Can operate up to 48 stations of combined decoder and conventional control making system retrofit easy
- DUAL-S external surge protection
- Waterproof connectors for connection to two-wire path supplied with all DUAL decoders and DUAL-S surge protection
- Number of 2-wire paths: 3

APPROVALS

CE, UL, cUL, C-tick

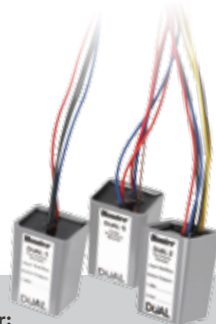
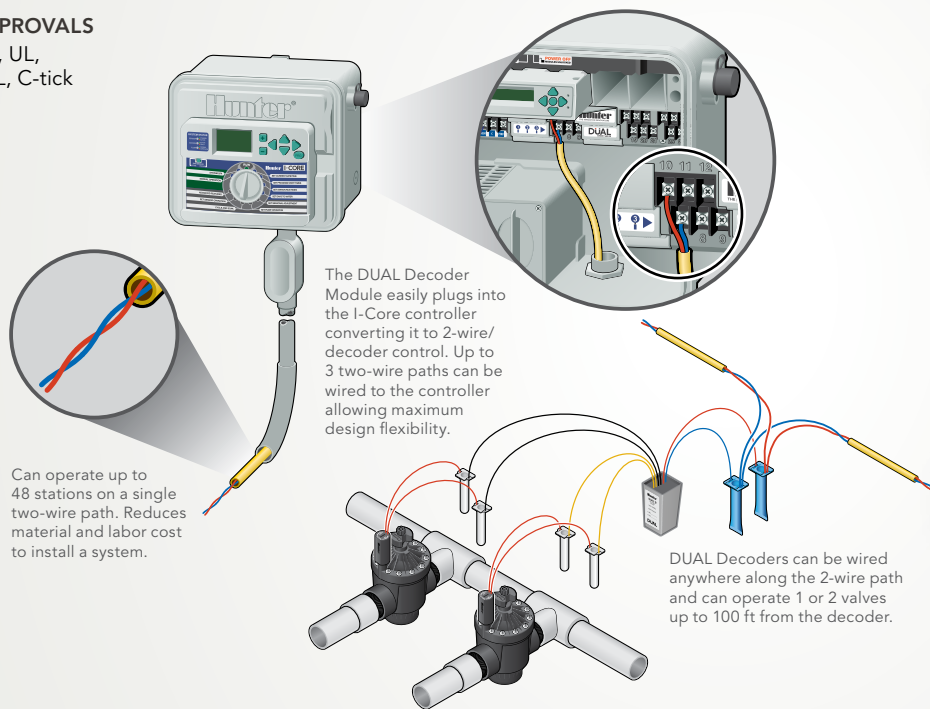

DUAL decoders and surge arrester:
3" H x 1 3/4" W x 2" D



DUAL decoder module:
1 3/8" H x 4 3/8" W x 4" D

SPECIFICATIONBUILDER

hunterindustries.com/DUAL

BASE MODELS

IC-600-PL = 6-Station controller, indoor/outdoor, plastic cabinet
IC-601-PL = International version, 6-Station controller, indoor/outdoor, plastic cabinet
IC-600-M = 6-Station controller, indoor/outdoor, metal cabinet
IC-600-PP = 6-Station controller, indoor/outdoor, plastic pedestal
IC-600-SS = 6-Station controller, indoor/outdoor, stainless steel cabinet

DUAL MODELS

DUAL48M = DUAL decoder output module. Plug-in module converts any ICORE controller to 2-wire decoder system (up to 48 stations maximum)
DUAL-1 = DUAL 1-station decoder (includes 2 DBRY-6 connectors)
DUAL-2 = DUAL 2-station decoder (includes 2 DBRY-6 connectors)
DUAL-S = DUAL surge arrester (includes 4 DBRY-6 connectors)

ID WIRE MODEL GUIDE

14 AWG (2 MM²) STANDARD DECODER CABLE

ID1GRY	Gray jacket
ID1PUR	Purple jacket
ID1YLW	Yellow jacket
ID1ORG	Orange jacket
ID1BLU	Blue jacket
ID1TAN	Tan jacket

12 AWG (3.3 MM²) LONG RANGE, HEAVY-DUTY DECODER CABLE

ID2GRY	Gray jacket
ID2PUR	Purple jacket
ID2YLW	Yellow jacket
ID2ORG	Orange jacket
ID2BLU	Blue jacket
ID2TAN	Tan jacket

ID WIRE MAXIMUM WIRE RUNS

ID 1 WIRE

5000 ft with DUAL systems
10,000 ft with ICD systems

ID 2 WIRE

7500 ft with DUAL systems
15,000 ft with ICD systems

ACC

APPLICATION: **High-End Commercial** NUMBER OF STATIONS: **12 to 42** TYPE: **Modular**

ACC IS THE MOST POWERFUL CONTROLLER FOR LARGE, SOPHISTICATED SITES.

FEATURES

- Number of stations: 12 to 24
- Type: Modular
- Enclosure: Outdoor
- Independent programs: 6
- Start times per program: 10
- Max. station run time: 6 hrs
- Warranty period: 5 years

ADVANCED FEATURES

- Easy Retrieve™ memory
- Compatible with Hunter Klik sensors and other micro-switch type weather sensors
- One touch manual start and advance for easy manual operation
- Rain sensor bypass
- Programmable rain delay
- Manual cycle
- Flow and alarm logs
- Test program allows for quick system checks
- Quick Check™
- Non-volatile memory
- Automatic short circuit protection
- Seasonal adjustment (global): 0% to 300% (in 1% increments)
- Seasonal adjustment (by program)
- Delay between stations (maximum): 6 hrs
- Sensor programmable by program
- Two pump/master valves programmable by station
- Simultaneous program operation: 6
- Total run time calculator
- Cycle and Soak
- No water window
- Backlit display makes it easy to program in low light applications
- Real time flow monitoring
- Factory installed SmartPort®
- Central control compatible with Hunter IMMSTM™
- Alphanumeric names for each program, station, or group
- Simultaneous station operation (includes master valve): 14 valves
- Automatic daily weather-based scheduling with optional Hunter Solar Sync sensor

• = Detailed descriptions on pages 73 and 74

ELECTRICAL SPECIFICATIONS

Transformer input: 120/240 VAC, 50/60 Hz
 Transformer output (24 VAC): 4.0 A
 Dual voltage transformer (120/240 VAC)
 Station output (24 VAC): 0.56 A
 P/MV output (24 VAC): 0.32 A
 Pump/master valve: 2, normally closed
 Sensor inputs: 4
 Operating temperature: 0° F to 140° F

APPROVALS

CE, UL, cUL, C-tick, FCC
 Enclosure rating (plastic & metal): IP24

ALL STAINLESS STEEL (SS) MODELS

American-made Type 304 Stainless Steel
 0.057" gauge steel
 Passivated for corrosion resistance



Metal Enclosures (gray or stainless):
 12³/₈" H x 15¹/₂" W x 6¹/₄" D



Metal pedestals (gray or stainless):
 37" H x 15¹/₂" W x 5" D (pedestal only)



Plastic pedestal:
 38³/₈" H x 21¹/₈" W x 15¹/₈" D

CONTROLLERS

SPECIFICATIONBUILDER

hunterindustries.com/ACC

BASE MODELS

ACC-1200 = 12-Station base unit controller, expands to 42 stations, metal cabinet
ACC-1200PP = 12-Station base unit controller, expands to 42 stations, plastic pedestal
ACC-PED = Metal pedestal, gray powder-coated, for use with I-Core and ACC metal controllers
PED-SS = Stainless steel pedestal for use with I-Core and ACC stainless controllers

STATION EXPANSION MODULES

ACM-600 = 6-Station plug-in module for use with the ACC-1200 series controllers
AGM-600 = 6-Station plug-in module for use with the ACC-1200 series controllers (extreme service lightning protection version)

EXAMPLES

ACC-1200	12-Station base unit, metal cabinet
ACC-1800	12-Station base unit with one ACM-600 module, and metal cabinet
ACC-2400 - PED	12-Station base unit, two ACM-600 modules and a metal pedestal
ACC-3000	12-Station base unit with three ACM-600 modules, and metal cabinet
ACC-3600	12-Station base unit with four ACM-600 modules, and metal cabinet
ACC-4200 - SS	12-Station base unit with five ACM-600 modules, and stainless steel cabinet



ACM-600

ACC-99D

APPLICATION
High-End Commercial

NUMBER OF STATIONS
1 to 99

TYPE
Decoder

THIS DECODER VERSION OF THE POWERFUL ACC PUTS CONTROL IN COMMAND.

Includes all features of the ACC Controller on page 80.

DECODER FEATURES

- Decoder station sizes available: 1, 2, 4, 6
- Sensor decoder available (ICD-SEN)
- Max. distance to decoder, 14 AWG wire path: 10,000 ft
- Max. distance to decoder, 12 AWG wire path: 15,000 ft
- Max. recommended distance, decoder to solenoid: 150 ft
- Field programmable
- ICD-HP wireless handheld programmer compatible
- Two-way communications
- Surge suppression: Internal (ground wire included)
- Dual pump/master valve outputs may be assigned to decoders
- Wire path connectors included with each decoder
- Number of wire paths: 6
- Automatic daily weather-based scheduling with optional Hunter Solar Sync sensor or IMMS-ET central system

APPROVALS

CE, UL, cUL, C-tick, FCC
Enclosure rating (metal & plastic): IP24



Decoders:
ICD-100, 200, ICD-SEN: 3 3/8" H x 1 1/2" W x 1/2" D
ICD-400, 600: 3 3/8" H x 1 3/4" W x 1 1/2" D
Height does not include wire leads

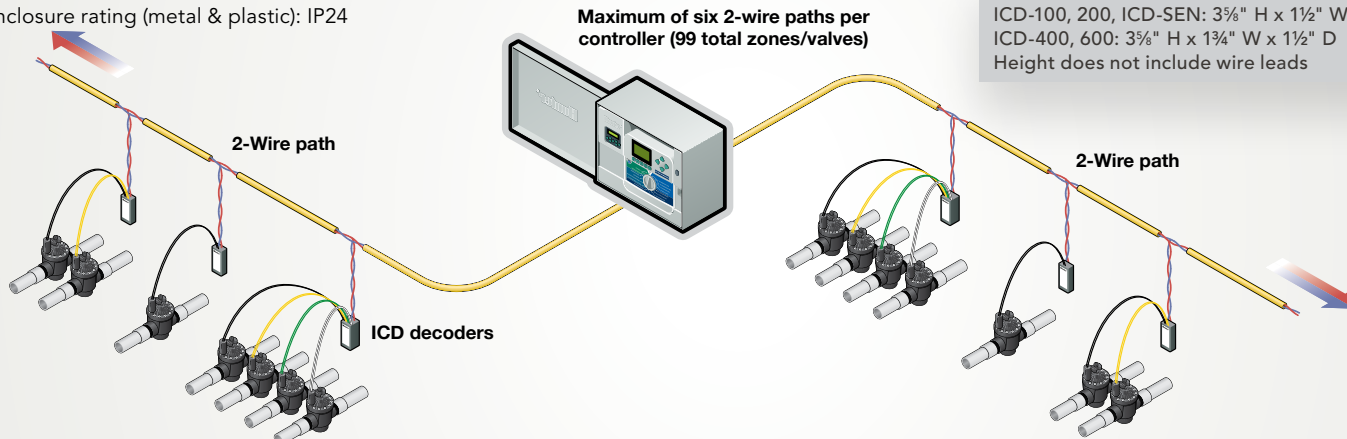

SPECIFICATIONBUILDER

hunterindustries.com/ACCD

BASE MODELS

ACC-99D = 2-Wire decoder controller with 99 station capacity, metal cabinet
ACC-99DPP = 2-Wire decoder controller with 99 station capacity, plastic pedestal
ACC-PED = Metal pedestal, gray powder-coated, for use with I-Core and ACC metal controllers
PED-SS = Stainless steel pedestal for use with I-Core and ACC stainless controllers

EXAMPLES

ACC-99D	2-wire decoder controller, metal cabinet
ACC-99D - PED	2-wire decoder controller, metal pedestal
ACC-99D - PP	2-wire decoder controller, plastic pedestal
ACC-99D - SS	2-wire decoder controller in stainless cabinet

ID WIRE MODEL GUIDE

14 AWG (2 MM ²) STANDARD DECODER CABLE		12 AWG (3.3 MM ²) LONG RANGE, HEAVY-DUTY DECODER CABLE	
ID1GRY	Gray jacket	ID2GRY	Gray jacket
ID1PUR	Purple jacket	ID2PUR	Purple jacket
ID1YLW	Yellow jacket	ID2YLW	Yellow jacket
ID1ORG	Orange jacket	ID2ORG	Orange jacket
ID1BLU	Blue jacket	ID2BLU	Blue jacket
ID1TAN	Tan jacket	ID2TAN	Tan jacket

ID WIRE MAXIMUM WIRE RUNS

ID 1 WIRE	ID 2 WIRE
5000 ft with DUAL systems	7500 ft with DUAL systems
10,000 ft with ICD systems	15,000 ft with ICD systems

DECODERS

SPECIFY SEPARATELY

ICD-100 = Single-station decoder with surge suppression and ground wire
ICD-200 = 2-station decoder with surge suppression and ground wire
ICD-400 = 4-station decoder with surge suppression and ground wire
ICD-600 = 6-station decoder with surge suppression and ground wire
ICD-SEN = 2-input sensor decoder with surge suppression and ground wire

Note: Each decoder includes 2 waterproof connectors for red and blue wires.

CONTROLLERS

HFS

APPLICATION

Commercial

TYPE

Flow Sensor

hunterindustries.com/HFS

KNOW THE FLOW WITH HFS, A SIMPLE AND ECONOMICAL SOLUTION FOR METERING AND REACTING TO ACTUAL FLOW CONDITIONS.

FEATURES

- Simple two wire connection to ACC and I-Core controllers (up to 1000 ft/300 m)
- Feeds flow data (gallons or liters) to controller, for flow recording and monitoring purposes
- Robust waterproof construction (used with appropriate FCT tees for pipe diameter, see table)
- Provides station level flow monitoring for reaction to high or low flow conditions
- Prevents damage and waste from leaks and breaks in piping system
- Compatible with ICD-SEN Sensor Decoder



Impeller-type flow meter, requires FCT for pipe installation (sold separately)

FLOW RANGE

FLOW SENSOR DIAMETER	OPERATING RANGE (GPM)		
	MINIMUM*	SUGGESTED MAXIMUM †	MAXIMUM (for sensor)
1"	6	17	50
1-1/2"	13	35	100
2"	20	55	200
3"	40	120	300
4"	60	200	400

* Minimum recommended flow for the highest flow zone for your system.
 † Good design practice dictates the maximum flow not to exceed 5 ft/sec. Suggested maximum flow is based upon Class 200 IPS plastic pipe.
 NOTE: Highest flow zone within irrigation system should not be more than 75% maximum available system flow.

SPECIFICATIONBUILDER

MODELS	DESCRIPTION	MODELS	SPECIFY SEPARATELY
HFS = ACC and I-CORE compatible flow sensor	Includes sensor only. Use with ACC and I-CORE controllers, sensor requires FCT for pipe installation (sold separately)	FCT-100 = 1" Schedule 40 sensor receptacle tee	
EXAMPLE		FCT-150 = 1-1/2" Schedule 40 sensor receptacle tee	
HFS		FCT-158 = 1-1/2" Schedule 80 sensor receptacle tee	
		FCT-200 = 2" Schedule 40 sensor receptacle tee	
		FCT-208 = 2" Schedule 80 sensor receptacle tee	
		FCT-300 = 3" Schedule 40 sensor receptacle tee	
		FCT-308 = 3" Schedule 80 sensor receptacle tee	
		FCT-400 = 4" Schedule 40 sensor receptacle tee	
		EXAMPLE	
		FCT-200	

CONTROLLERS

ICD-HP

APPLICATION

Commercial

TYPE

Decoder Programmer

hunterindustries.com/ICDHP

THE INDISPENSABLE FIELD TOOL FOR THE DECODER PROFESSIONAL.

FEATURES

- Industrial grade handheld meter with waterproof programming cup
- Communicates with decoder through plastic case—wireless electro-magnetic induction saves waterproof connectors
- Compatible with Hunter ICD or DUAL series decoders
- USB powered for shop or office use; 4 x AA batteries for field use
- All test leads and cables included in durable, foam-padded carrying case
- Turn decoder stations on and view solenoid status, current in milliamps, and more
- Program or re-program decoder stations, whether new or installed
- Program any station numbers in any order, or skip stations for future expansion
- Simplifies setup and diagnostics for sensor decoders
- Sensor test functions for Clik and Flow sensors, plus built-in multimeter
- Backlit adjustable display
- 6 international operating languages (English, Spanish, French, Italian, German, Portuguese)
- Warranty period: 5 years

ELECTRICAL SPECIFICATIONS

Power input: 4 x AA batteries, or standard USB connector (included)

Communications: Wireless induction
 Fused test leads for unpowered decoder functions

APPROVALS

FCC, CE, C-tick
 (no license required)



ICD-HP: Handheld programmer

SPECIFICATIONBUILDER

MODEL	DESCRIPTION
ICD-HP = Handheld programmer	Wireless handheld decoder programmer, includes all test and power leads, programming cup, and rugged carrying case

EXAMPLE

ICD-HP

XC HYBRID

APPLICATION
Residential/Commercial

NUMBER OF STATIONS
4, 6, 8, 10, 12

TYPE
Fixed

GET THE POWER WITHOUT THE PLUG WITH THE BATTERY-POWERED XC HYBRID.

FEATURES

- Battery or AC powered
- Number of stations: 4, 6, 8, 10, 12 (plastic); 6, 12 (stainless)
- Type: Fixed
- Enclosures: Indoor/outdoor plastic; outdoor stainless
- Independent programs: 3
- Start times per program: 4
- Max. station run time: 4 hrs
- Warranty period: 2 years

ADVANCED FEATURES

- Easy Retrieve™ memory
 - Compatible with Hunter Klik sensors and other micro-switch type weather sensors (wireless sensors not compatible)
 - One touch manual start and advance for easy manual operation
 - Rain sensor bypass
 - Programmable rain delay: 1 to 7 days
 - Manual cycle
 - Test program allows for quick system checks
 - Non-volatile memory
 - Seasonal adjustment (global): 10% to 150%
 - Delay between stations (maximum): 4 hrs
 - Sensor programmable by zone
- = Detailed descriptions on pages 73 and 74

ELECTRICAL SPECIFICATIONS

Operates DC latching solenoids only
Pump/master valve
Sensor inputs: 1
Operating temperature: 0° F to 140° F
Uses 6 AA batteries (plastic model)
Uses 6 C batteries (stainless model)

MAXIMUM WIRE RUN - METRIC

Wire Size	Max Distance (feet)
18 AWG	500
16 AWG	800
14 AWG	1300
12 AWG	2000

* Use DC-Latching solenoids only

OPTIONAL

24 VAC input transformer:
120 VAC plug in transformer (P/N 526500)
240 VAC plug in transformer (European P/N 545700)
240 VAC plug in transformer (Australian P/N 545500)
DC latching solenoids (P/N 458200)
Pole mount for stainless steel model

APPROVALS

CE, UL, cUL, C-tick
IP24 (plastic model)



Plastic indoor/outdoor:
8 7/8" H x 7" W x 3 3/4" D



Stainless steel outdoor:
9 3/4" H x 7 7/8" W x 4 1/4" D



Stainless steel outdoor:
9 3/4" H x 7 7/8" W x 4 1/4" D
Steel pole: 4'

SPECIFICATIONBUILDER

hunterindustries.com/XCHYBRID

MODELS

XCH-400 = 4-Station indoor/outdoor controller
XCH-600 = 6-Station indoor/outdoor controller
XCH-600-SS = 6-Station outdoor controller, stainless
XCH-800 = 8-Station indoor/outdoor controller
XCH-1000 = 10-Station indoor/outdoor controller
XCH-1200 = 12-Station indoor/outdoor controller
XCH-1200-SS = 12-Station outdoor controller, stainless

EXAMPLE

XCH-400	4-Station indoor/outdoor controller
XCH-600-SS	6-Station outdoor controller, stainless

OPTIONS

SPECIFY SEPARATELY

XCHSPOLE = Steel mounting pole (4 ft)
XCHSPB = Stainless steel mounting bracket (required for pole)

NODE

APPLICATION
Residential/Commercial

NUMBER OF STATIONS
1, 2, 4, 6

TYPE
Battery Operated,
Fixed

THE NODE BRINGS BATTERY-POWERED CONTROL TO SITES WITH NO ELECTRICITY.

FEATURES

- Battery powered
- Number of stations: 1, 2, 4, 6
- Type: Fixed
- Enclosure: Outdoor
- Independent programs: 3
- Start times per program: 4
- Max. station run time: 6 hrs
- Warranty period: 2 years

ADVANCED FEATURES

- Standard controller programming for 3 programs with 4 start times each
- Seasonal adjustment 10-150%
- Accepts single or double 9 volt batteries for extended battery life
- Battery Life Indicator
- Master Valve operation (available in 2, 4, 6 station models)
- Programable Off
- Manual Cycle
- Compatible with Hunter Clk sensors and other micro-switch type weather sensors (wireless sensors not compatible)
- Sensor Bypass function
- Waterproof to 12 feet
- Solenoid wire length up to 100 feet (18 AWG)

ELECTRICAL SPECIFICATIONS

Sensor inputs: 1
 Power source: 9-volt battery
 Operates DC latching solenoids only
 (P/N 458200)
 Operating temperature: 0° F to 140° F

APPROVALS

IP68, CE

Various Configurations

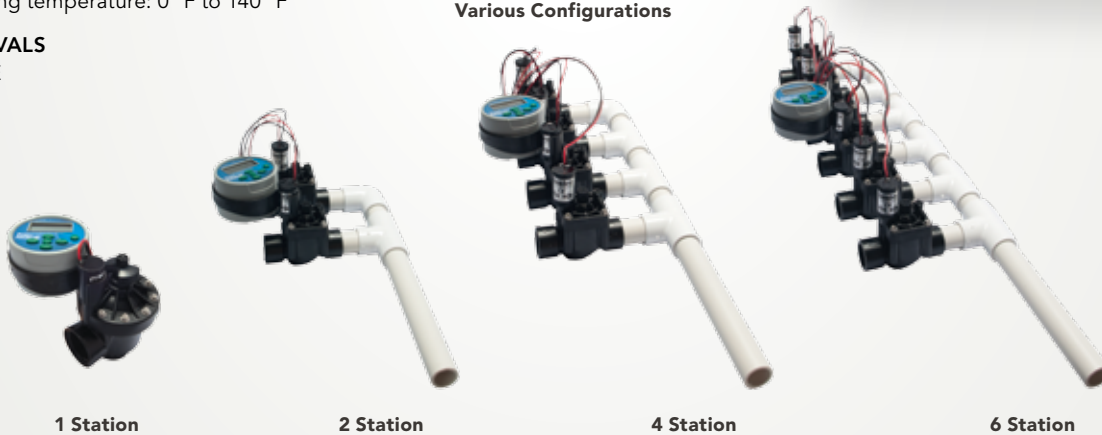

1 Station

2 Station

4 Station

6 Station



NODE-100
3½" diameter x 2½" tall

**NODE-200,
NODE-400,
NODE-600 (shown)**

**NODE-100-Valve
NODE-100-ValveB (BSP thread)**

CONTROLLERS

SPECIFICATIONBUILDER

hunterindustries.com/NODE

MODELS

NODE-100 = Single station controller (DC latching solenoid included)
NODE-200 = 2-Station controller (DC latching solenoid ordered separately)
NODE-400 = 4-Station controller (DC latching solenoid ordered separately)
NODE-600 = 6 station controller (DC latching solenoid ordered separately)
NODE-100-VALVE = Single station controller with PGV-101G valve and DC latching solenoid (NPT threads)
NODE-100-VALVE-B = Single station controller with PGV-101G-B valve and DC latching solenoid (BSP threads)

EXAMPLES

NODE-100
NODE-100-VALVEB

WVS

APPLICATION: Residential/Commercial
 NUMBER OF STATIONS: 1, 2, 4
 TYPE: Fixed

WVS IS A BATTERY-POWERED, WIRELESS PROGRAMMABLE CONTROLLER FOR HARD-TO-REACH PLACES.

FEATURES

- Battery powered
- Number of stations: 1, 2, 4
- Type: Fixed
- Enclosure: Outdoor
- Program by station
- Start times per program: 9
- Max. station run time: 4 hrs
- Warranty period: 2 years

ADVANCED FEATURES

- Compatible with Hunter Klik sensors and other micro-switch type weather sensors (wireless sensors not compatible)
- One touch manual start and advance for easy manual operation
- Programmable rain delay
- Manual cycle
- Non-volatile memory
- Low battery indicator
- Waterproof (to 12 ft)
- Wireless remote programming

ELECTRICAL SPECIFICATIONS

Simultaneous station operation: Up to 4
 Sensor inputs: 1
 Power source: 9-volt battery
 Operates DC latching solenoids only (P/N 458200)
 Operating temperature: 0° F to 140° F
 Frequency of operation: 900 MHz ISM band
 No FCC license required

APPROVALS

IP68, CE



WVP (left): 11½" L x 3" W x 2" H
 WVC (right): 3¼" D x 5" H

SPECIFICATIONBUILDER

hunterindustries.com/WVS

MODELS

- WVC-100 = Single station wireless controller (DC latching solenoid ordered separately)
- WVC-200 = 2-Station wireless controller (DC latching solenoid ordered separately)
- WVC-400 = 4-Station wireless controller (DC latching solenoid ordered separately)

WVP = Wireless valve programmer to be used with wireless valve controllers

OPTIONS

- (blank) = 900 MHz ISM band (US/Australia)
- E = 869.85 MHz (Europe)

EXAMPLES

WVC-100
WVP

PUMP START RELAY

hunterindustries.com/PSR

FOR SYSTEMS THAT USE A PUMP, PSR DELIVERS RELIABILITY FOR LESS.

FEATURES

- Choice of three models sized accordingly to fit your particular application
- NEMA 3R rated locking plastic enclosure rated for outdoor use, weather resistance and security
- 24 VAC flying leads make it quick and easy to wire to controller
- The PSR-22 meets demanding electrical requirements for UL approval, and the PSR-52/-53 contain UL-approved relays



Compact design:
 Enclosure measures 6½" H x 7½" W x 4½" D

Electrical Specifications

Models	Single Phase		3 Phase	Max. Full Load AMPS	Max. Resistive AMPS	Coll VA		Coll VA	
	HP at 110 VAC	HP at 240 VAC	HP at 240 VAC			Inrush	(Amps)	Holding	(Amps)
PSR-22	2*	5*	N/A	22	22	31	(1.29)	7	(0.29)
PSR-52	5	7.5	N/A	40	50	56	(2.33)	6	(0.25)
PSR-53	5	7.5	10	40	50	56	(2.33)	6	(0.25)

* Approximate power

ROAM

APPLICATION
Residential/Light Commercial

RANGE
1000'

hunterindustries.com/ROAM

THE ROAM REMOTE ALLOWS FOR CONTROLLER OPERATION UP TO 1000 FEET.

FEATURES

- Designed to work with Hunter ACC, I-Core, Pro-C, PCC, and X-Core controllers through a SmartPort® connection
- 128 programmable addresses for use of multiple ROAM remotes in the same neighborhood
- Variable run times to adjust run time without modifying regular program
- Maximum stations supported: 240
- Run times: 1 to 90 minutes
- Range: Up to 1000 ft (line of sight)
- Transmitter power source: 4 AAA batteries (included)
- Receiver power source: 24 VAC, 10 mA (provided by controller)
- System operating frequency: 433 MHz
- FCC approved



Transmitter and receiver:
7" H x 2¼" W x 1¼" D

SmartPort®

ROAM and ICR remote controls require the installation of a SmartPort wiring harness*. This consists of a connector that is wired to the SmartPort terminal on the controller, and that will accept either the ROAM or ICR remote receiver.

* ACC and I-Core controllers include pre-wired SmartPorts for remote operation.



SPECIFICATIONBUILDER

MODELS

ROAM-KIT = Transmitter, receiver (SmartPort® wiring harness, and 4 AAA batteries included)
ROAM-TR = Transmitter (4 AAA batteries included)
ROAM-R = Receiver
ROAM-WH = SmartPort wiring harness (length: 6 ft)
SRR-SCWH = Shielded SmartPort wiring harness (length: 25 ft)

EXAMPLES

- ROAM-KIT**
- ROAM-R**

ICR

APPLICATION
Commercial

RANGE
2 Miles

REMOTELY ACCESS CONTROLLERS UP TO TWO MILES AWAY.

FEATURES

- Up to 2 mile range for remote manual operation of Hunter irrigation systems
- Designed to work with Hunter ACC, I-Core, Pro-C, PCC, and X-Core controllers through a SmartPort® connection
- 128 different programmable addresses
- Variable run times to change run time without modifying regular program
- Display shows remaining battery life
- Maximum stations supported: 240
- Run times: 1 to 90 minutes
- Large LCD display, push-button operation
- Transmitter power source: 4 AA alkaline batteries (included)
- Receiver power source: 24 VAC, from controller through a SmartPort® connector
- System operating frequency: 27 MHz band
- SmartPort can be mounted up to 50' from controller (use SRR-SCWH shielded cable wiring harness)
- FCC approved: No FCC license required
- Rugged plastic carrying case included



Transmitter (no antenna):
6½" H x 3¼" W x 1¼" D
Receiver (no antenna):
6¼" H x 3" W x 1¼" D

SPECIFICATIONBUILDER

MODELS

ICR-KIT = Transmitter, Receiver, SmartPort® wiring harness, and carrying case
ICR-TR = Handheld transmitter (4 AA batteries included)
ICR-R = Receiver unit (SmartPort wiring harness included)
ICR-CASE = Plastic carrying case
ROAM-WH = SmartPort wiring harness (length: 6 ft)
SRR-SCWH = Shielded SmartPort wiring harness (length: 25 ft)

OPTIONS

(blank) = No option
A = Australia and other international markets

EXAMPLES

- ICR-KIT**

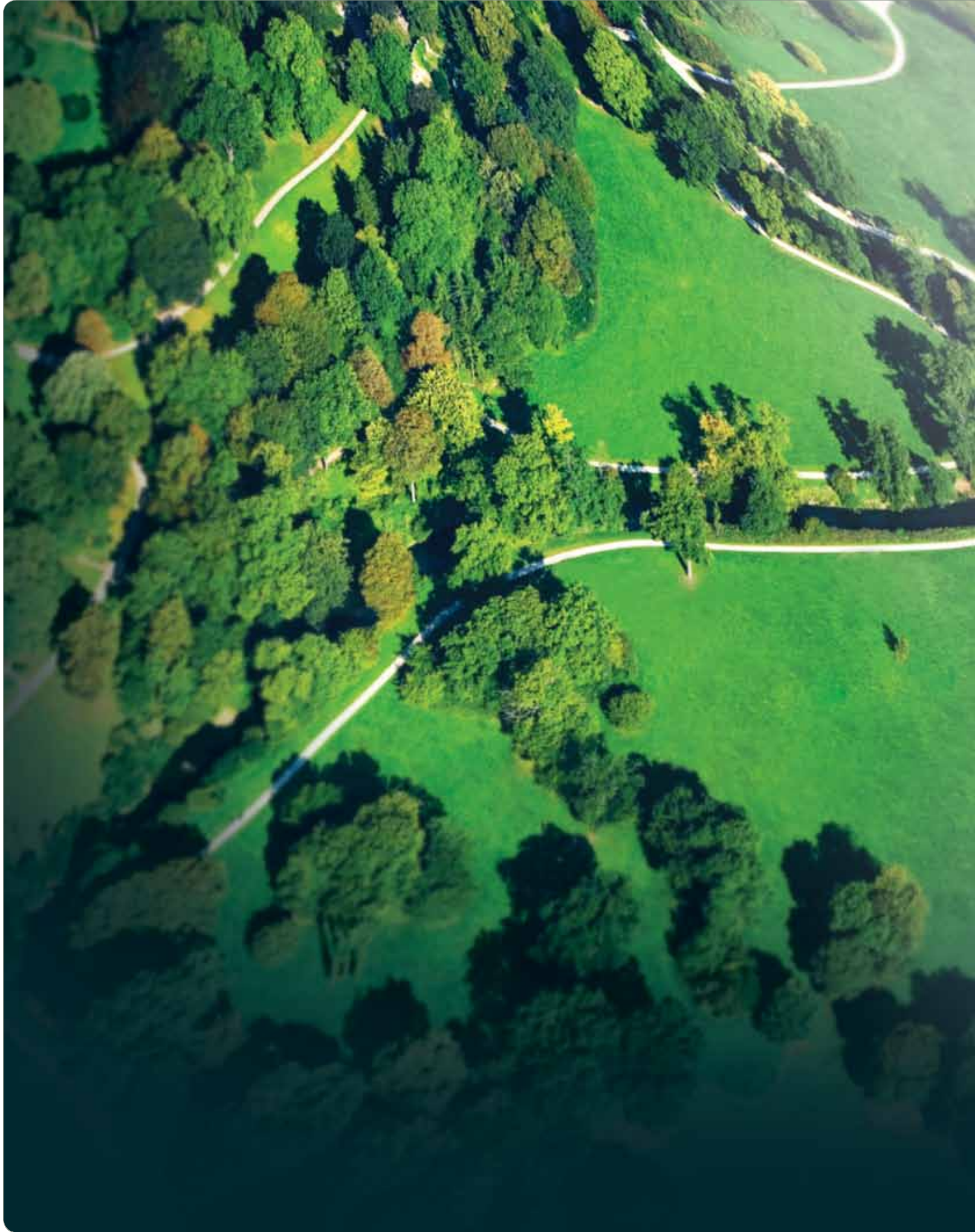

An aerial photograph of a lush green landscape. A winding road or path cuts through the fields, leading towards a large, dense cluster of trees. The scene is captured from a high angle, showing the curvature of the earth and the vibrant green of the vegetation.

CENTRAL CONTROL SYSTEM

SEE THE WORLD FROM A DIFFERENT VIEW. Make that every view. With Hunter's powerful IMMS 3.0, any Site can be controlled centrally and simply. With two-way communication, flow monitoring, remote shut down, and interactive map graphics, this software leaves no system unseen.

IMMS 3.0

SITES
Up to 100

CONTROLLERS
Up to 10,000

STATIONS
Up to 990,000

IMMS IS DESIGNED FOR WIDE-AREA CENTRAL CONTROL, INCLUDING ET WATER SAVINGS AND FLOW REPORTING.

FEATURES

- Windows-based programming and communications software
- Total control of each controller's functions
- Graphical user interface with customizable map-based navigation
- Flow monitoring and reporting with Hunter ACC controllers
- Alarm reporting and detailed irrigation history reports
- Wireless and hardwired communications options, including Ethernet and GPRS options
- Controller sharing of communications channels to reduce communications costs

ADVANCED FEATURES

- Optional IMMS-ET provides automatic evapo-transpiration adjustment to adjust watering to local conditions
- Uses cost-effective local ET sensors, sharing ACC communications
- Point-specific ET with no monthly fees
- Full station level ET database with plant, soil, and sprinkler information
- Automatic alarm and flow monitoring for maintenance management
- Built-in Ethernet LAN option with easy configuration via browser

KEY SPECIFICATIONS

Operating system: Microsoft Windows XP, Vista, or Windows 7, 32 or 64 bit

Minimum RAM: 512 MB

Minimum screen resolution: 1024 x 768

Storage: At least 100 MB disk space

COMPATIBLE CONTROLLERS

IMMS is optimized for the Hunter ACC controller and accessories (including decoder controllers).

IMMS is also compatible with Hunter model Pro-C controllers, with reduced functionality.

COMPATIBLE SENSORS

HFS: Hunter Flow-Clik sensor for ACC controllers (one per controller). Provides flow total reporting and flow alarm monitoring with diagnostic shutdowns in real time.

Cliks: Each controller should have its own rain sensor for fast rain shutdowns. All Hunter Clik sensors are compatible with ACC and other IMMS controllers.

ET Sensor: ET Sensor platform is for use with IMMS-ET software.

ET Sensor is added to selected ACC controllers, to report local conditions. This local ET data has no additional monthly charges and can be shared through the software to create schedules for other controllers in the same micro-climate. Add as many ET Sensors as needed to sample all micro-climates.



Local ET Sensor, includes Rain Gauge



Add a visual dimension to central control with background map graphics.



Track flow and other vital statistics in both charts and spreadsheets.



Station level symbols can be positioned over background images from any source.

SPECIFICATIONBUILDER

hunterindustries.com/IMMS

SOFTWARE

MODELS	DESCRIPTION	NOTES
IMMS3CD	IMMS 3 graphics central control software	Custom images not included
IMMS-ET-CD	Optional ET automatic weather adjustment software (requires IMMS3CD base model)	Requires an ET Sensor at one or more ACC controller locations

IMMS 3.0

SITES
Up to 100

CONTROLLERS
Up to 10,000

STATIONS
Up to 990,000

COMMUNICATIONS COMPONENTS

ACC: Communications options are installed inside the ACC controller cabinet. No additional enclosures or power are necessary for these options.

Wall mount communications installation

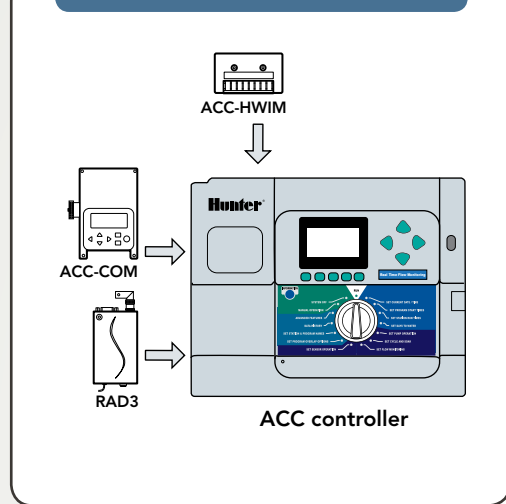

Plastic pedestal communications installation

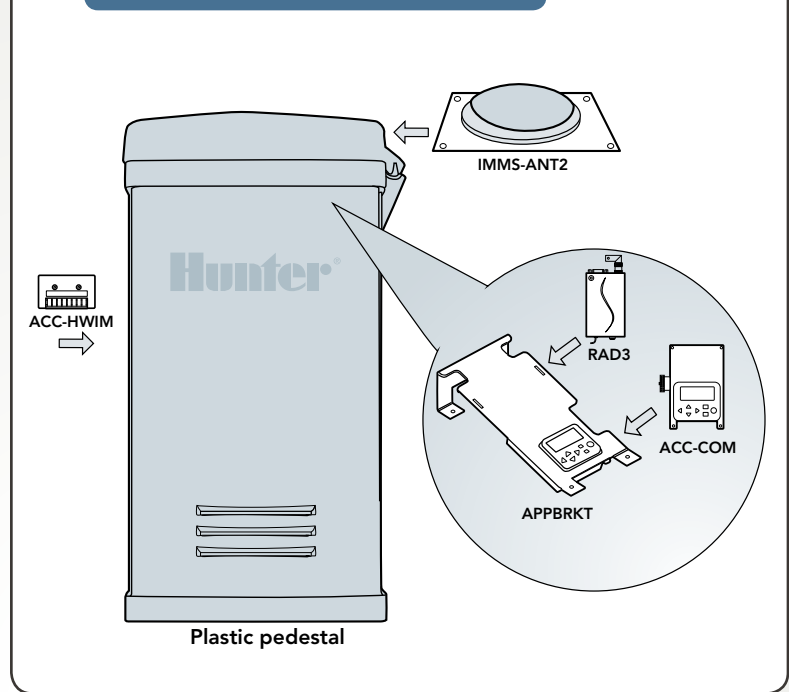

SPECIFICATIONBUILDER

hunterindustries.com/IMMS

COMMUNICATION OPTIONS FOR ACC INTERFACE		SPECIFY SEPARATELY
MODELS	OPTIONS	PURPOSE
ACC-COM-HWR = Hardwire/radio module	(blank) = No option	Supports hardwire and radio communication options
ACC-COM-POTS = Dial-up modem module (also supports radio and hardwire)	(blank) = No option	Supports dial-up telephone line input in addition to hardwire and radio communication sharing
ACC-COM-GSM = CSD cellular module (also supports radio and hardwire)	E = International frequencies	Supports GSM mobile input in addition to hardwire and radio communication sharing (cell service required)
ACC-COM-LAN = Ethernet module (also supports radio and hardwire)	(blank) = No option	Supports TCP/IP in Ethernet networks in addition to hardwire and radio sharing with local controllers.
ACC-COM-GPRS = GPRS cellular data module (also supports radio and hardwire)	E = International frequencies	Supports mobile data connection via GPRS phone in addition to hardwire and radio sharing with local controllers

EXAMPLES

ACC-COM-HWR	Hardwire/radio module
ACC-COM-POTS	Dial-up modem module
ACC-COM-GSM - E	CSD cellular module for international frequencies

USER INSTALLED OPTIONS		SPECIFY SEPARATELY
MODELS	DESCRIPTION	PURPOSE
ACC-HWIM	Hardwire interface module required for hardwire connections	Provides surge protected terminals for hardwired cable connections
RAD3	UHF radio module (North America), 450-470 MHz	UHF radio module for wireless connections (<i>license and antenna required and not included</i>)
APPBRKT	Communication bracket for plastic pedestals	Holds Com modules and accessories in plastic pedestal (<i>not required in wall mounts</i>)

BASE	MODELS	OPTIONS	PURPOSE	SPECIFY SEPARATELY
IMMS-CCC	Hardwire central interface	None = 120 VAC (North America) E = 230/240 VAC (Europe/international power) A = 230/240 VAC (Australia)	Hardwired central interface for connection to Site via direct wire (GCBL cable), supplied with USB cable for connection to central computer, and plug-in transformer	
GCBL*	None = up to 4000' spool 100 = 100'/30 m 300 = 300'/90 m 500 = 500'/150 m		Cable for all IMMS hardwired communications	

* GCBL available in 1000'/300 m increments (up to 4000'/1200 m)

IMMS 3.0

SITES
Up to 100

CONTROLLERS
Up to 10,000

STATIONS
Up to 990,000

SYSTEM CONFIGURATIONS (ACC CONTROLLERS)

- Determine how you will reach the first controller on each Site.
 - Dial-up landline: Add ACC-COM-POTS to controller
 - Hardwire cable: Add one IMMS-CCC at the computer, and ACC-COM-HWR plus one ACC-HWIM at the controller
 - GSM cell phone: Add ACC-COM-GSM to controller (requires CSD service plan)
 - Ethernet local area network: Add ACC-COM-LAN at the controller, and connect to the network (RJ-45 jack)
 - GPRS cell phone: Add ACC-COM-GPRS to controller (requires GPRS coverage and service contract)

- Determine how that first controller will reach the other controllers on the Site.
 - If by radio, add one RAD3 (US) or RAD460INT (international) plus antenna to the controller
 - If by hardwire cable, add one ACC-HWIM (if it is not already present as in 1)
- Equip the other controllers. Add one ACC-COM-HWR to each controller, plus:
 - One ACC-HWIM when hardwire connection will be necessary
 - One RAD3 plus antenna when radio connections are necessary

Consult factory for detailed system design information.

SAMPLE CONFIGURATIONS

Many other configurations possible, consult factory or System Design Guide for details.

SPECIFICATIONS

ACC-COM-HWR, POTS, GSM, GSM-E, LAN, GPRS
 3¼" x 4½" x 1¾"
 Powered internally via data connection
 Mounted internally to ACC controller

RAD3, RAD460INT: 450-470 MHz, Power Output: 1 Watt, Bandwidth: 12.5 kHz narrowband

ACC-HWIM: Hardwire interface module for 4-20 ma loop communications, includes 8 color-coded terminals for GCBL connection. Installs inside ACC controller cabinets or pedestals.

HARDWARE COMMUNICATIONS CABLE

GCBL shielded, two twisted pair 18 AWG wire with ground wire, up to 10,000' between each device

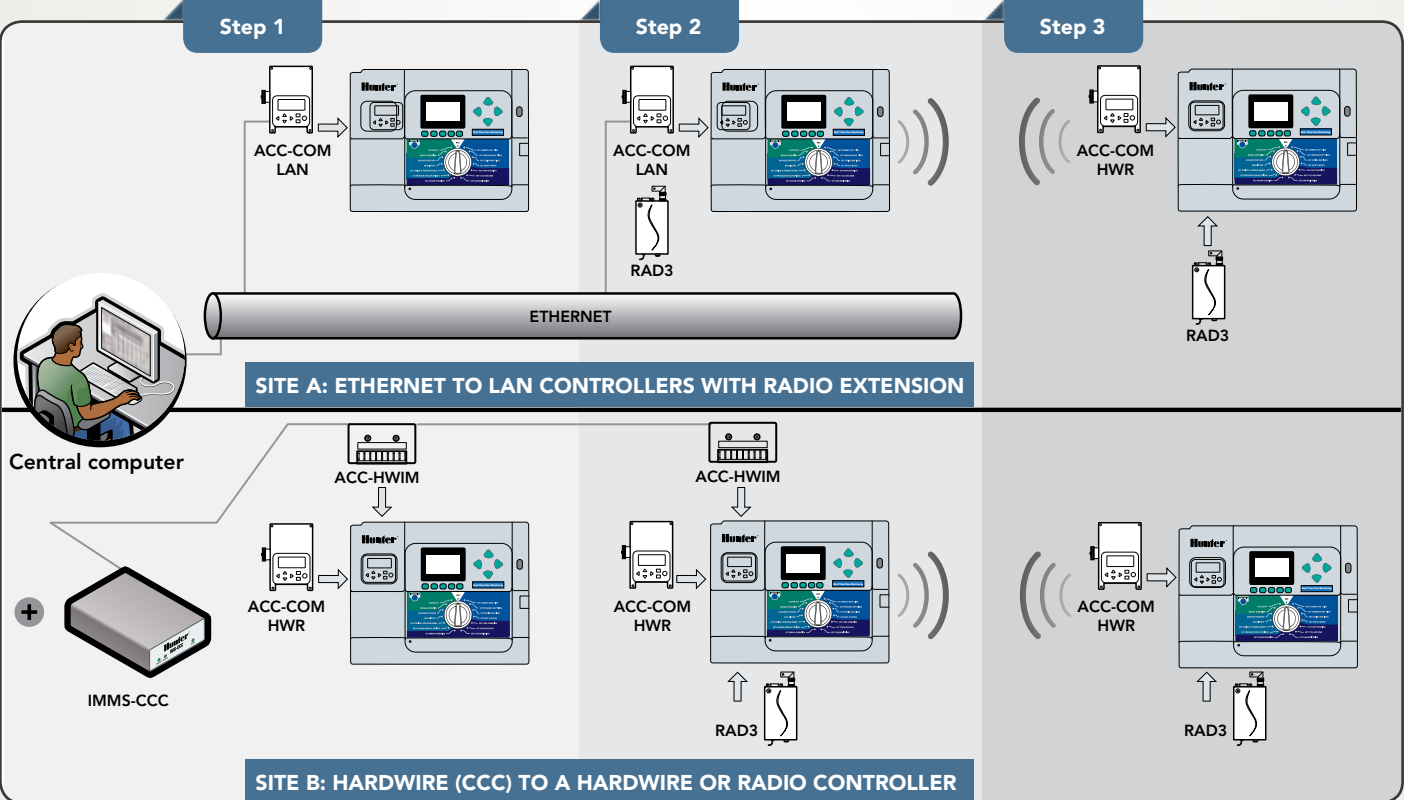

SPECIFICATIONBUILDER

hunterindustries.com/IMMS

RADIO ANTENNA OPTIONS		SPECIFY SEPARATELY
MODELS	DESCRIPTION	
IMMSANT2	Omni-directional antenna for plastic pedestal lid installation	
IMMSANT3	Omni-directional antenna for wall or pole mount installation	
IMMSANTYAGI3	High efficiency directional antenna for pole installation	
RA5M	High gain omni-directional mast antenna for roof or pole installations	

SENSORS

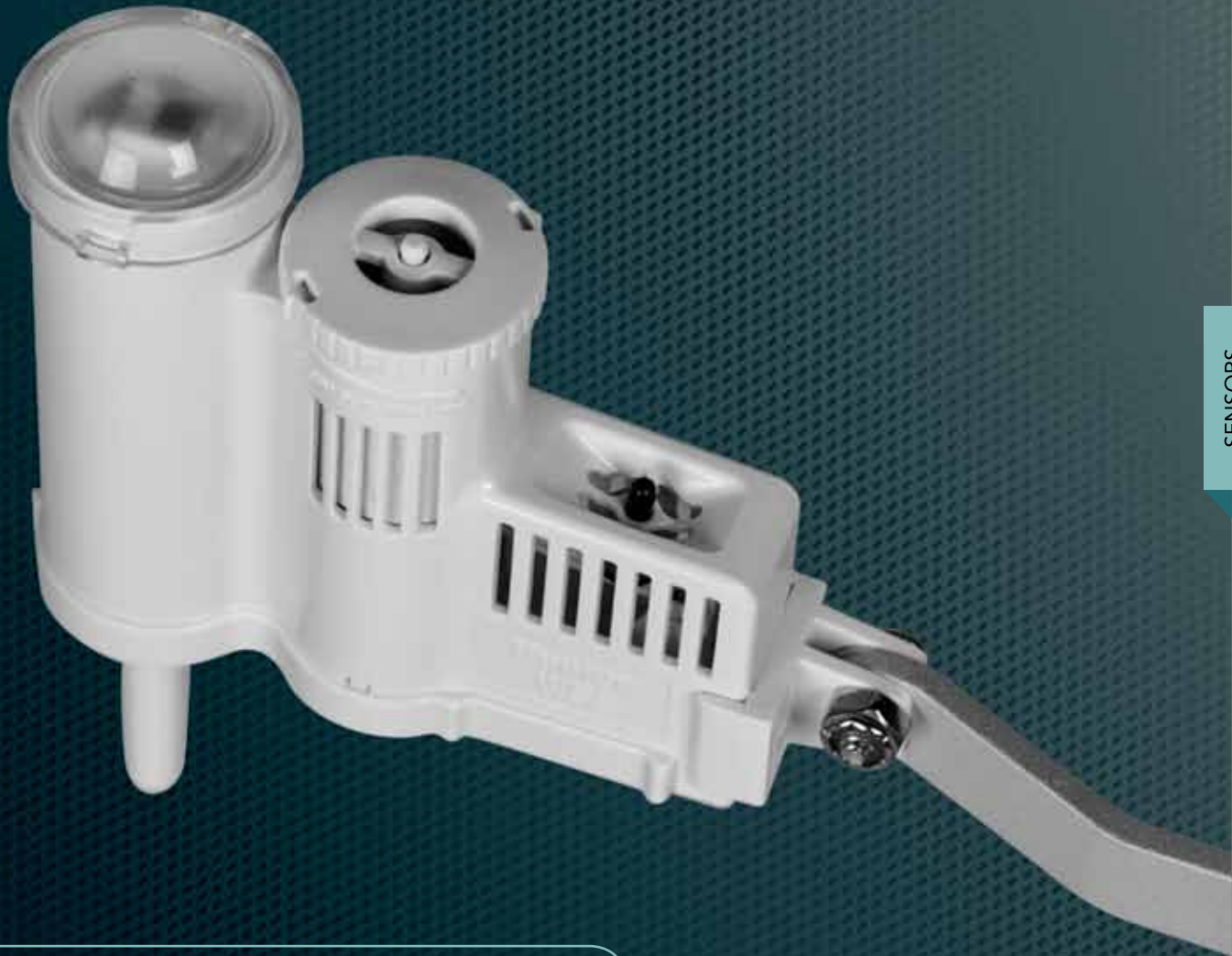

SENSORS

OUTWIT THE WEATHER. No matter what the weather forecast may say, Hunter sensors are ready for any weather at any time. The entire lineup offers a level of additional protection unmatched in the industry. **No matter rain, ice, wind, or sun, a Hunter sensor is ready for it all.**

MINI-CLI[®]

hunterindustries.com/MINICLIK

MINI-CLI IS THE SIMPLEST WAY TO SHUT DOWN SYSTEMS DURING RAINFALL.

FEATURES

- Easily installs on any automatic irrigation system
- Debris tolerant for reliable operation and no unnecessary shutdowns
- Can be set to shut system off from 1/8" to 1" of rainfall
- Includes 25' of 20 gauge sheathed, two-conductor, UL-approved wire
- Optional user-installed metal gutter mount for Mini-Click[®] (order SGM)
- Warranty period: 5 years

SPECIFICATIONS

Switch rating: 24 VAC, 5 A

Wiring: Typically interrupts the common ground wire between the solenoid valves and the controller

UL listed

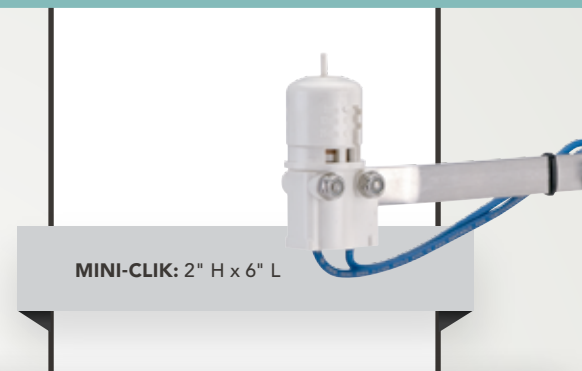

SPECIFICATIONBUILDER

MODEL	OPTIONS
MINI-CLI	(blank) = No option HV = High voltage model for 110/220 VAC applications C = Conduit mount NO = Normally open switch

USER INSTALLED OPTION SPECIFY SEPARATELY

SGM = Optional gutter mount
SG-MC = Stainless steel sensor guard enclosure for Mini Click

EXAMPLES

MINI-CLI	Mini-Click rain sensor
MINI-CLI - C	Mini-Click rain sensor with conduit mount

FREEZE-CLI[®]

hunterindustries.com/FREEZECLI

WHEN FRIGID TEMPS SET IN, FREEZE-CLI STOPS SPRINKLERS TO AVOID DANGEROUS, ICY CONDITIONS.

FEATURES

- Installs easily with no adjustment needed
- Accurate temperature sensing shuts system off when air temperature reaches 37° F
- Used with other sensors to enhance overall efficiency of irrigation systems
- Warranty period: 5 years

Note: Not intended for agricultural applications.

SPECIFICATIONS

Switch rating: 24 VAC, 5 A

Wiring: Typically interrupts the common ground wire between the solenoid valves and the controller

UL listed



SPECIFICATIONBUILDER

MODEL	OPTIONS
FREEZE-CLI	(blank) = No option REV = Reverse switching

EXAMPLE

FREEZE-CLI

WIND-CLI[®]

hunterindustries.com/WINDCLI[®]

WHEN HIGH WINDS KICK IN, WIND-CLI[®] SHUTS SYSTEMS DOWN.

FEATURES

- Adjusts to activate at various wind speeds
- Two types of operation: "normally open" or "normally closed" wiring
- Adjustable reset wind speeds
- Can control fountain systems to eliminate overspray in windy conditions
- Warranty period: 5 years

SPECIFICATIONS

Switch rating: 24 VAC, 5 A maximum

Wind speed adjustment:

Actuation speed: 12 to 35 mph

Reset speed: 8 to 24 mph

Mounts: Slip fits over 2" PVC pipe or attaches to ½" conduit with adapter (supplied with unit)



WIND-CLI: 4" H
Wind vane diameter: 5"

SPECIFICATIONBUILDER

MODEL	OPTIONS
WIND-CLI = Wind sensor	(blank) = No option (normally closed) NO = Normally open switch

EXAMPLE

WIND-CLI

SENSORS

MINI WEATHER STATION

hunterindustries.com/MWS

MWS HELPS ANY SYSTEM BATTLE WIND, RAIN, AND FREEZING TEMPERATURES.

FEATURES

- Compact sensor that monitors wind, rain, freezing temperatures, and shuts the irrigation system off as weather conditions require
- Installs easily on automatic irrigation system
- Set wind speed shutdown from 12 to 35 mph
- Set rain shutdown from ⅛" to 1" of rainfall
- Automatically shuts off system when temperatures fall below 37° F
- Warranty period: 5 years

SPECIFICATIONS

Electrical rating: 24 VAC, 5 A maximum

Wind vane diameter: 5"

Wind speed adjustments:

Actuation speed: 12 to 35 mph

Reset speed: 8 to 24 mph

Freeze-Click[®] temperature set point: 37° F

Mounts: Slip fits over 2" PVC pipe or attaches to ½" conduit with adapter (supplied with unit)



SPECIFICATIONBUILDER

MODEL	OPTIONS
MWS = Wind and rain sensors	(blank) = No option FR = Combines wind, rain and freeze sensors

EXAMPLE

MWS - FR Wind and rain sensors with a freeze sensor added

RAIN-CLIK™

hunterindustries.com/RAINCLIK

RAIN-CLIK'S QUICK RESPONSE™ TURNS OFF SYSTEMS THE INSTANT RAIN STARTS TO FALL.

FEATURES

Models: Rain-Clík, Rain/Freeze-Clík, Wireless Rain-Clík, Wireless Rain/Freeze-Clík

- Quick Response™ feature shuts the system off as soon as it starts raining
- Maintenance-free design with 10-year battery life
- Adjustable vent ring allows for setting of reset delay
- Rugged polycarbonate housing and metal extension arm
- Rain-Clík includes 25' of 20 gauge sheathed, two-conductor, UL-approved wire

- Wire-free operation allows easy installation on new or existing systems
- Sensor operates up to 800 ft. from receiver unit
- Built-in bypass switch on receiver panel
- Wireless Rain/Freeze-Clík sensor protects against ice caused by irrigation on landscapes, roads, and walkways
- Compatible with most controllers
 - General Warranty: 5 years
 - Battery Warranty (wireless model): 10 years

SPECIFICATIONS

- Wiring: normally closed or normally open
- Time to turn off irrigation system: 2 to 5 minutes approx. for Quick Response
- Time to reset Quick Response: 4 hours approx. under dry, sunny conditions
- Time to reset when fully wet: 3 days approx. under dry, sunny conditions
- Operating temperature: 32° F to 130° F
- UL listed, CUL (CSA), CE
- Optional user installed gutter mount for Rain-Clík (order SGM)
- Switch rating: 24 VAC, 3 A
- Freeze sensor shuts system off when temperatures fall below 37° F (Rain/Freeze-Clík model)
- System operating frequency: 433 MHz
- UL listed, FCC approved, suitable for use in Australia, CUL (CSA), CE
- Communication range up to 800 ft. line of sight*
- Wireless Rain/Freeze-Clík shuts system off when temperatures fall below 37° F
- Receiver input power: 24 VAC (from controller)

• = Applicable to Rain-Clík only

• = Applicable to Wireless Rain-Clík only

• = Applicable to Rain-Clík and Wireless Rain-Clík

* Consult with factory for compatibility in export markets.

APPROVAL

FCC

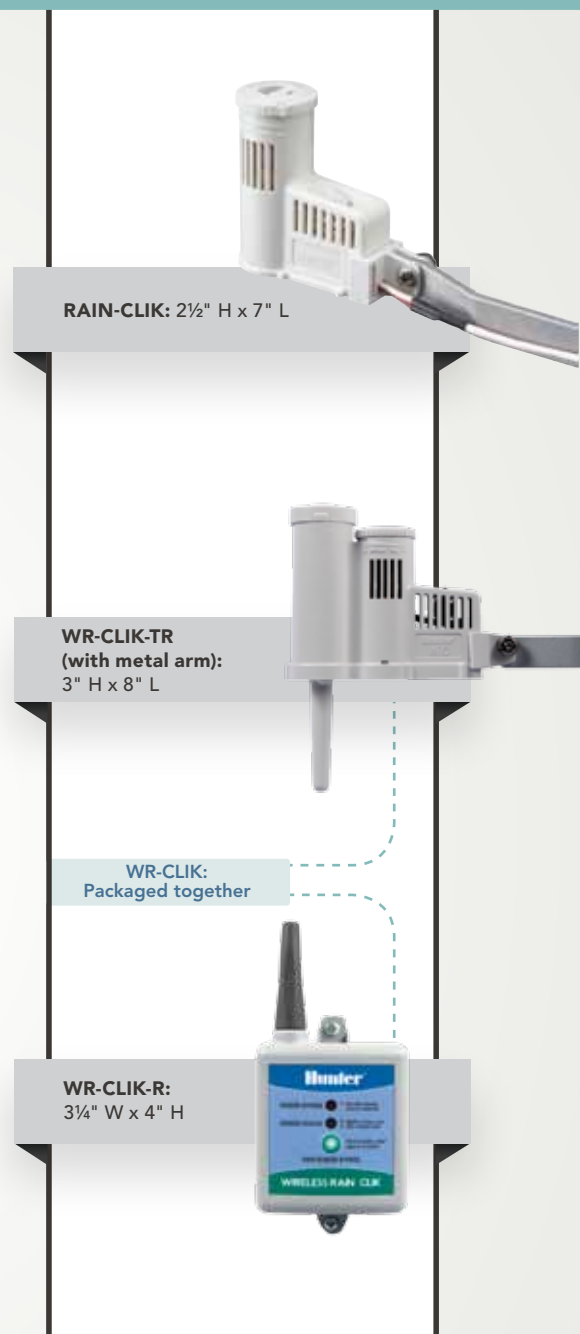

SPECIFICATIONBUILDER

MODEL	OPTIONS
RAIN-CLIK = Rain-Clík sensor	(blank) = No option NO = Normally open switch SGM = Optional gutter mount
RFC = Rain/Freeze-Clík sensor	

MODELS
WR-CLIK = Wireless Rain-Clík system
WRF-CLIK = Wireless Rain/Freeze-Clík system

USER INSTALLED OPTION	SPECIFY SEPARATELY
SGM = Optional gutter mount	

USER INSTALLED OPTION	SPECIFY SEPARATELY
SGM = Optional gutter mount (included in the WRF-CLIK)	

EXAMPLES

RAIN-CLIK	Rain-Clík sensor
RFC - SGM	Rain/Freeze Clík sensor with gutter mount

EXAMPLES

WR-CLIK	Wireless Rain-Clík system
WRF-CLIK	Wireless Rain/Freeze-Clík system with gutter mount

FLOW-CLIK™

hunterindustries.com/FLOWCLIK

WHEN RUPTURES OR LEAKS OCCUR, FLOW-CLIK ENSURES WATER FLOW IS STOPPED IMMEDIATELY.

FEATURES

- Automatically shuts down system if an overflow condition occurs
- Calibration for precise system control: Single button allows each system to be programmed at a specified flow level
- Protects from flooding damage and erosion
- Works with all Hunter and most non-Hunter controllers
- Multi-color LED provides system status to display when power is applied, and indicate if flow is within limits
- Compatible with all commercial and residential piping systems: Large flow range provides complete flexibility
- Warranty period: 5 years

FLOW-CLIK INTERFACE PANEL

36" leads provided for easy wiring to controller
(2 wires to controller 24 VAC terminals and
2 wires to sensor and terminals)

Current draw: 24 VAC, 0.025 A

Switching current: 2 A maximum

Max. distance between interface panel and sensor:
1000 ft. (18 gauge minimum wire size);
2 wires required for Flow-Clik sensor;
4 wires required for Flow-Clik IMMSTM sensor

Programmable start up delay:
0 to 300 seconds

Programmable interrupt period:
2 to 60 minutes

System status indicator light

One button system calibration to set
to highest flow zone



SENSORS

SPECIFICATIONBUILDER

MODELS	DESCRIPTION	MODELS	SPECIFY SEPARATELY
FLOW-CLIK = Standard kit for all 24 VAC controllers	Includes sensor and interface panel, sensor requires FCT for pipe installation (sold separately)	FCT-100 = 1" Schedule 40 sensor receptacle tee	
FLOW-CLIK-IMMS = IMMS SI/CI only compatible flow sensor	Includes sensor only. Use with IMMS SI/CI only, sensor requires FCT for pipe installation (sold separately)	FCT-150 = 1-1/2" Schedule 40 sensor receptacle tee	
		FCT-158 = 1-1/2" Schedule 80 sensor receptacle tee	
		FCT-200 = 2" Schedule 40 sensor receptacle tee	
		FCT-208 = 2" Schedule 80 sensor receptacle tee	
		FCT-300 = 3" Schedule 40 sensor receptacle tee	
		FCT-308 = 3" Schedule 80 sensor receptacle tee	
		FCT-400 = 4" Schedule 40 sensor receptacle tee	

EXAMPLE

FLOW-CLIK

EXAMPLE

FCT-200

FLOW RANGE

FLOW SENSOR DIAMETER	OPERATING RANGE (GPM)		
	MINIMUM*	SUGGESTED MAXIMUM**	MAXIMUM (for sensor)
1"	6	17	50
1-1/2"	13	35	100
2"	20	55	200
3"	40	120	300
4"	60	200	400

* Minimum recommended flow for the highest flow zone for your system.

** Good design practice dictates the maximum flow not to exceed 5ft/sec. Suggested maximum flow is based upon Class 200 IPS plastic pipe.

NOTE: Highest flow zone within irrigation system should not be more than 75% maximum available system flow.

SOLAR SYNC

hunterindustries.com/SOLARSYNC

SOLAR SYNC MONITORS LOCAL WEATHER AND ADJUSTS IRRIGATION RUNTIMES, MAKING HUNTER CONTROLLERS SMARTER.

FEATURES

- Provides automated daily adjustment to program run times
- Wired and wireless models available
- No Water Window programming available in most controllers (see page 74)
- Rain and freeze shutoff
- Gutter mount bracket included
- General Warranty: 5 years
- Battery Warranty (wireless model): 10 years

ELECTRICAL SPECIFICATIONS

- Maximum distance sensor to module: 200'
- 40' of wire included in kit
- Solar Sync compatible with Pro-C, PCC, and I-Core controllers
- Solar Sync SEN compatible with X-Core and ACC controllers
- Rain and Freeze sensor shutdown capability included in sensor
- ☁ Wireless sensor and receiver with 800' maximum range
- ☁ Wireless Solar Sync compatible with Pro-C, PCC, and I-Core controllers
- ☁ Wireless Solar Sync SEN compatible with X-Core and ACC controllers
- = *Applicable to Solar Sync only*
- ☁ = *Applicable to wireless Solar Sync only*
- = *Applicable to Solar Sync and wireless Solar Sync*

APPROVAL

FCC



SOLAR SYNC



SOLAR SYNC - SEN



WSS



WSS - SEN

Solar Sync sensor with mounting arm:
3" H x 8½" W x 1" D



Solar Sync module:
1¾" H x 5" W x ¾" D



Wireless Solar Sync sensor with mounting arm:
4½" H x 8½" W x 1" D



Wireless Solar Sync receiver:
5½" H x 1½" W x 1½" D



SPECIFICATIONBUILDER

MODELS

SOLAR SYNC = Solar Sync sensor (40'*)
Solar Sync module (includes 10 year lithium battery and rubber module cover)

For use with PCC, Pro-C, and I-Core controllers

SOLAR SYNC-SEN† = Solar Sync sensor (module not included)

* Max. distance from sensor to controller: 40'
† For use with X-Core and ACC controllers

EXAMPLES

SOLAR SYNC

SOLAR SYNC-SEN

MODELS

WSS = Wireless Solar Sync sensor (800'*)
Solar Sync module (includes 10 year lithium battery and rubber module cover)

For use with PCC, Pro-C, and I-Core controllers

WSS-SEN† = Wireless Solar Sync sensor only (800'*)

* Max. distance from wireless sensor to receiver: 800'
† For use with X-Core, and ACC controllers

EXAMPLES

WSS

WSS-SEN

ET SYSTEM

hunterindustries.com/ETSYSTEM

FOR ADVANCED CONTROL, THE ET SYSTEM AUTOMATICALLY CREATES AN IRRIGATION PROGRAM DAILY BY MEASURING EVAPOTRANSPIRATION RATES.

FEATURES

- Calculates evapotranspiration (ET) for individual microclimate to fit the exact landscape requirements
- Specific irrigation scheduling for every zone based on the characteristics of each
- Enables compliance with local watering restrictions
- Easily upgrades Hunter PCC and Pro-C to weather-based controllers
- Non-volatile memory
- Full range of scheduling options
- Includes 100 ft. of 18 AWG, 2-conductor for sensor installation
- WiltGuard™ technology triggers protective watering when extreme conditions threaten plants
- Warranty period: 2 years

SPECIFICATIONS

Station maximum: 48

Power input: 24 VAC, 50/60 Hz (from host controller)

Current draw: 20 mA, maximum

Max. distance, ET Sensor from module: 100'

Sensor wire: Includes 100' of UL approved wire

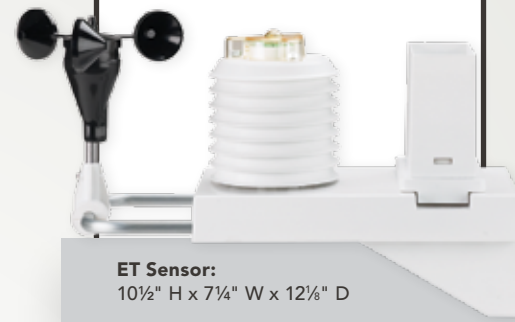
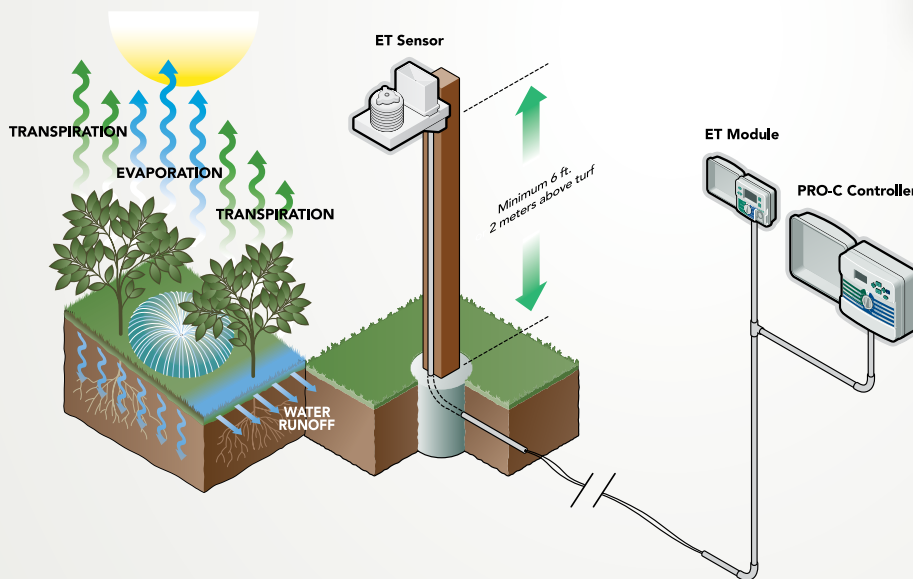

ET Sensor:
10½" H x 7¼" W x 12⅝" D

ET SYSTEM:
Packaged together



ET Module: 6" H x 4" W x 13¼" D

Dimensions

ET Sensor with pole brackets:
10½" H x 7¼" W x 13" D

ET Sensor with ET Wind:
11½" H x 7¼" W x 19⅞" D

ET Sensor and ET Wind with pole brackets: 11½" H x 7¼" W x 20¾" D

SPECIFICATIONBUILDER

MODELS SPECIFY SEPARATELY FROM CONTROLLER

ET SYSTEM = ET Sensor with outdoor interface ET Module, for direct connection to Hunter PCC and Pro-C controllers

ET WIND = Optional anemometer to gather wind speed data

ET SENSOR = ET Sensor only for use with IMMS-ET installations

EXAMPLE

ET SYSTEM



DRIP/MICRO

IRRIGATION'S SECRET WEAPON. Flowerbeds, highway medians, and groundcovers all benefit from the targeted accuracy of micro-irrigation, which puts water only where it is needed, with greatly reduced risk of runoff and waste.

PLD

APPLICATION
Residential/Commercial

FLOW RATES
0.4, 0.6, 1.0 GPH

SPECIFIC AND PRECISE, PLD DELIVERS WATER WITHOUT THE WASTE.

PLD FEATURES

- In-line pressure-compensating emitters provide consistent high-quality performance
- Built-in check valve prevents emitter clogging and wasteful runoff
- Available emitter spacing of 12", 18", or 24"
- Emitter flow rates available in 0.4, 0.6, or 1.0 GPH
- Blank tubing available (no emitters)
- Comes in 250' and 1,000' coils
- Superior flexibility and kink resistance
- Works with Drip Zone Control Kits
- 100' rolls available in models PLD 0612100, PLD 1012100, and PLD 1018100
- Warranty period: 5 years (including 2 additional years for environmental stress cracking)

PLD FITTINGS FEATURES

- Ideal for use with all PLD drip line products
- Quick and easy connections without using tools or glue
- Handles pressures up to 50 PSI
- UV resistant
- Same color as original PLD drip line for a perfect blend under mulch

OPERATING SPECIFICATIONS

Pressure compensating, non-draining emitters

Operating pressure range: 15 to 50 PSI

Recommended filtration: 120 Mesh

Accepts 17 mm insert fittings

PLD Insert Fittings

Model	Description
PLD050	Barb to 1/2" NPT Adapter
PLD075	Barb to 3/4" NPT Adapter
PLDCPL	Barb to Barb Coupling
PLDELB	Barb to Barb, 90° Elbow
PLDTEE	Barbed Tee
PLDCAP	Barb to End Cap
PLDBV	Barbed Valve
PLD075TBTEE	3/4" Female Thread x 17 mm Barb Tee
PLD-AVR	Air Relief Valve

Additional charts located on page 117

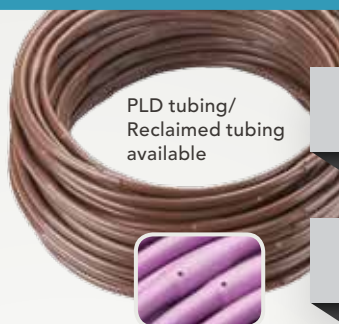

PLD tubing/
Reclaimed tubing
available



PLD-050 fitting:
1/2" MPT x 17 mm barb

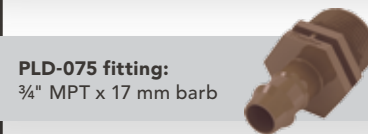

PLD-075 fitting:
3/4" MPT x 17 mm barb



PLD-CPL fitting:
17 mm Barb x barb coupling

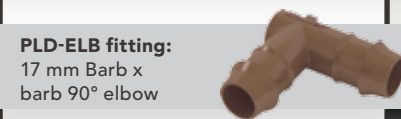

PLD-ELB fitting:
17 mm Barb x
barb 90° elbow



PLD-TEE fitting:
17 mm Barb x barb tee

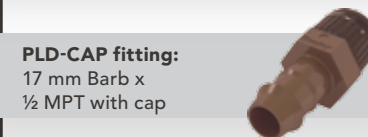

PLD-CAP fitting:
17 mm Barb x
1/2" MPT with cap



PLD-BV fitting:
17 mm Barb x
barb shut-off valve



PLD075TBTEE:
3/4" Female thread x
17 mm barb tee



PLD-AVR:
1/2" Threaded air/vacuum
relief valve

SPECIFICATIONBUILDER

hunterindustries.com/PLD

MODELS	SPACING	LENGTH	OPTIONS
PLD-04 = 0.4 GPH Flow	12 = 12"	100 = 100'	(blank) = No option
PLD-06 = 0.6 GPH Flow	18 = 18"	250 = 250'	R = Reclaimed
PLD-10 = 1.0 GPH Flow	24 = 24"	1K = 1,000'	
PLD-BLNK = Blank			

EXAMPLES

PLD-04 - 12 - 250	0.4 GPH landscape dripline with 12" spacing in a 250' roll
PLD-06 - 12 - 100	0.6 GPH landscape dripline with 12" spacing in a 100' roll
PLD-10 - 24 - 250 - R	1.0 GPH landscape dripline with 24" spacing in a 250' roll, with reclaimed option
PLD-BLNK - 100	100' Roll of blank tubing
PLD - AVR	1/2" MPT air relief/anti-vacuum valve

MICRO IRRIGATION

APPLICATION

Residential/Commercial

USES

Precise Area Watering

MICRO IRRIGATION WATERS WITH PINPOINT ACCURACY.

SOLO-DRIP

- Eight streams of water for accurate watering
- Fingertip cap control for flow and radius adjustment
- Operating specifications: 15 to 30 PSI
- Dimensions:
A: SD-T: 0.95" H x 0.78" W x 0.63" D
B: SD-B: 0.95" H x 0.78" W x 0.63" D
C: SD-B-STK: 6.0" H x 1.7" W x 0.63" D



Solo-Drip

HALO-SPRAY

- Large diameter, umbrella of water
- Adjust radius as needed
- Combine several for a "blanket" of water
- Operating specifications: 15 to 30 PSI
- Dimensions:
A: HS-T: 0.95" H x 0.78" W x 0.63" D
B: HS-B: 0.95" H x 0.78" W x 0.63" D
C: HS-B-STK: 6.0" H x 1.7" W x 0.63" D



Halo-Spray

TRIO-SPRAY

- Full-, half-, and quarter-circle configurations
- Functions like big sprays on a micro level
- Control knob for specific adjustment
- Operating specifications: 10 to 30 PSI
- Dimensions:
A: TS-F: 1.5" H x 0.9" W x 0.6" D
B: TS-H: 1.5" H x 0.9" W x 0.6" D
C: TS-Q: 1.5" H x 0.9" W x 0.6" D



Trio-Spray

Solo-Drip Performance Data

	Pressure (PSI)	Flow (GPH)	Diameter of Throw (ft)
Adjustable to Maximum (approx 20 clicks)	15.0	0-11	0-1.5
	20.0	0-12.5	0-1.9
	30.0	0-15.7	0-2.7

Halo-Spray Performance Data

	Pressure (PSI)	Flow (GPH)	Diameter of Throw (ft)
Adjustable to Maximum (approx 14 clicks)	15.0	0-14	0-5.8
	20.0	0-16	0-7.7
	30.0	0-20	0-11.5

Trio-Spray Performance Data

Pressure (PSI)	Flow (GPH)	SPRAY PATTERN		
		Diameter of Throw (in)	Radius of Throw (in)	
			360° x 18 Hole	180°
10.0	0-16.7	0-17	0-7	0-6
15.0	0-20.3	0-19	0-8	0-7
20.0	0-23.4	0-20	0-9	0-8
25.0	0-26.1	0-22	0-10	0-9.0
30.0	0-28.6	0-23	0-11	0-10

SPECIFICATIONBUILDER

hunterindustries.com/MICRO

MODELS	OPTIONS
SD = Solo-Drip	T = 10-32 Threads, 360° B = Barb, 360° B-STK = Barb with stake, 360°
HS = Halo-Spray	T = 10-32 Threads, 360° B = Barb, 360° B-STK = Barb with stake, 360°
TS = Trio-Spray	T-F = 10-32 Threads, 360° T-H = 10-32 Threads, 180° T-Q = 10-32 Threads, 90°

EXAMPLES

SD - T	Solo-Drip with 10-32 threads, 360°
HS - B	Halo-Spray with barb, 360°
TS - T-F	Trio-Spray with 10-32 threads, 360°

DRIP ZONE CONTROL KITS

APPLICATION

Residential/Commercial Micro Irrigation

DRIP CONTROL KITS BRING TOGETHER A VALVE, FILTER, AND PRESSURE REGULATOR FOR TOTAL COMMAND OF A ZONE.

FEATURES

- Factory-assembled and water-tested
- Highest quality components (SS filter screen, standard flush cap, top of the line regulator)
- Filter Sentry™ diaphragm screen cleaning system on ICZ kits
- Wide flow range to cover most micro irrigation applications

OPERATING SPECIFICATIONS

ACZ-075:

Pressure regulation: 25 or 40 PSI
 Flow: 0.5 to 15 GPM (30 to 900 GPH)
 Operating pressure: 20 to 120 PSI
 Operating temperature: up to 150° F
 150 mesh SS screen

ICZ-101:

Pressure regulation: 25 or 40 PSI
 Flow: 2 to 20 GPM (120 to 1200 GPH)
 Operating pressure: 20 to 120 PSI
 Operating temperature: up to 150° F
 150 mesh SS screen

PCZ-101:

Pressure regulation: 25 or 40 PSI
 Flow: 0.5 to 15 GPM (30 to 900 GPH)
 Operating pressure: 20 to 120 PSI
 Operating temperature: up to 150° F
 150 mesh SS screen

ICZ-151:

Pressure regulation: 40 PSI
 Flow: 20 to 60 GPM
 Operating pressure: 20 to 120 PSI
 Operating temperature: up to 150° F
 120 mesh SS screen

SOLENOID OPERATING SPECIFICATIONS

Heavy-duty solenoid: 24 VAC, 370 mA inrush current, 190 mA holding current, 60 cycles, 475 mA inrush current, 230 mA holding current, 50 cycles

FACTORY INSTALLED OPTIONS

25 or 40 PSI regulator (ACZ-075, PCZ-101, ICZ-101)

USER INSTALLED OPTIONS

Reclaimed water ID for ACZ-075 and PCZ-101 (P/N 269205)

Reclaimed water ID for ICZ-101 (P/N 561205)

Additional charts located on page 118



DRIP / MICRO

SPECIFICATIONBUILDER

hunterindustries.com/DRIPKITS

MODELS	OPTIONS
ACZ-075 = ¾" PGV-ASV valve with ¾" HY075 filter system	25 = 25 PSI regulator (excluding ICZ-151) 40 = 40 PSI regulator
PCZ-101 = 1" PGV globe valve with 1" HY100 filter system	
ICZ-101 = 1" ICV globe valve with 1" HY100 filter system	
ICZ-151 = 1½" ICV globe valve with 1" HY100 filter system	

EXAMPLES

ACZ-075 - 25	¾" PGV-ASV valve with ¾" HY075 filter system, and 25 PSI regulator
PCZ-101 - 25	1" PGV globe valve with 1" HY100 filter system, and 25 PSI regulator
ICZ-101 - 40	1" ICV globe valve with 1" HY100 filter system, and 40 PSI regulator



DESIGN ILLUSTRATION

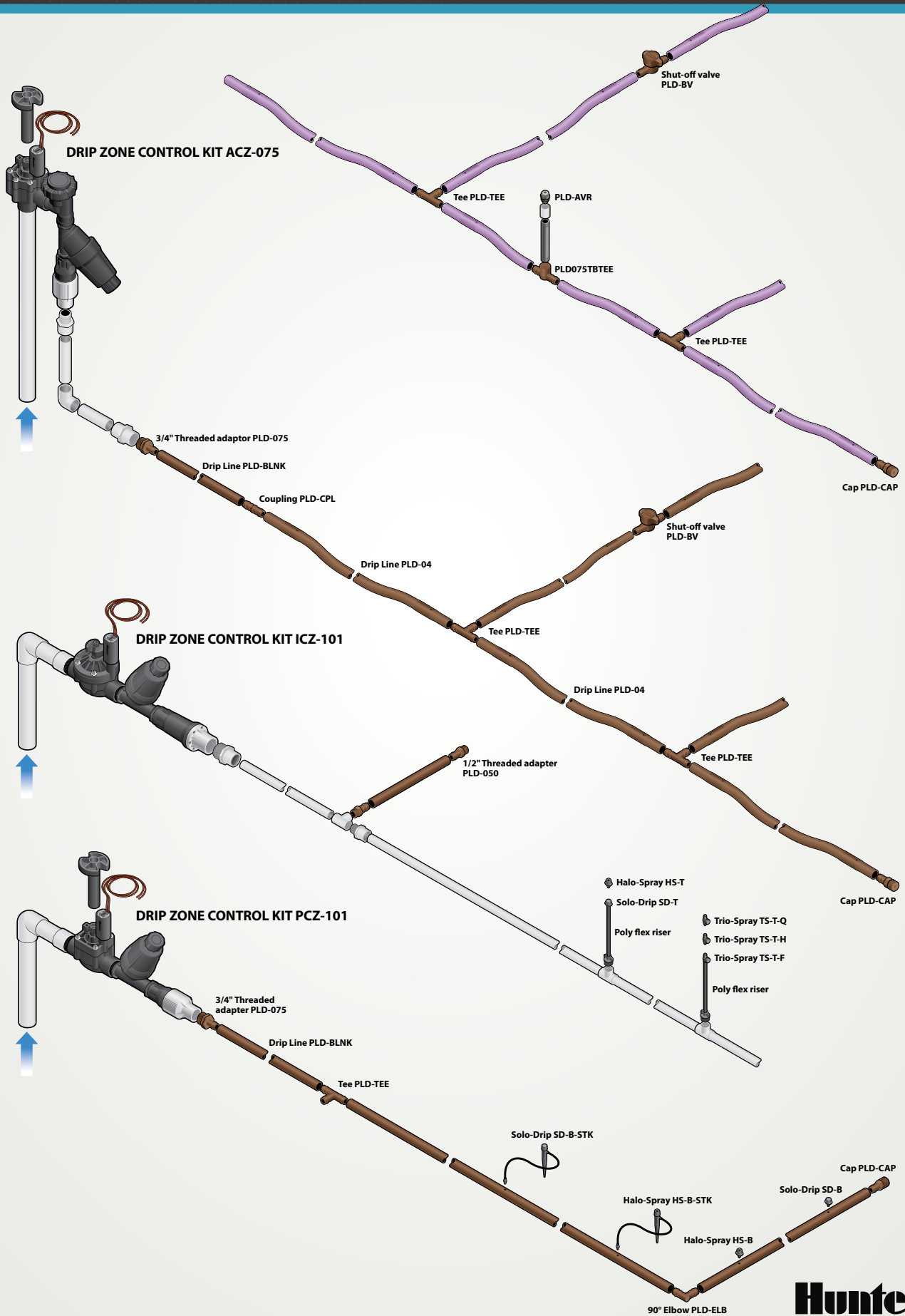

ROOT ZONE WATERING SYSTEM

APPLICATION
Residential/Commercial
Shrub and Tree Irrigation

SIZES
10", 18", 36"

FLOW RATES
0.25 or
0.50 GPM

**FOR HEALTHIER TREES AND SHRUBS,
GET TO THE ROOT OF THINGS.**

FEATURES

- Built in Hunter Swing Joint for direct installation to 1/2" PVC fitting
- Patented StrataRoot baffles divert water to root zone while adding strength to the unit
- Locking cap

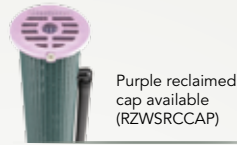

DIMENSIONS

- 10": 2" diameter x 10" length
- 18": 3" diameter x 18" length
- 36": 3" diameter x 36" length

OPERATING SPECIFICATIONS

Bubbler flow rates: 0.25 or 0.50 GPM
Recommended pressure range: 15 to 70 PSI

FACTORY INSTALLED OPTIONS

- Check valve
- Locking reclaimed purple cap

USER INSTALLED OPTIONS

- Sleeve: Fabric sleeve that helps prevent soil intrusion in sandy soils (P/N RZWSLEEVE)
- Replacement cap 18" and 36" only (P/N RZWS-CAP)
- Locking reclaimed purple cap 18" and 36" only (P/N RZWS-RCCAP)

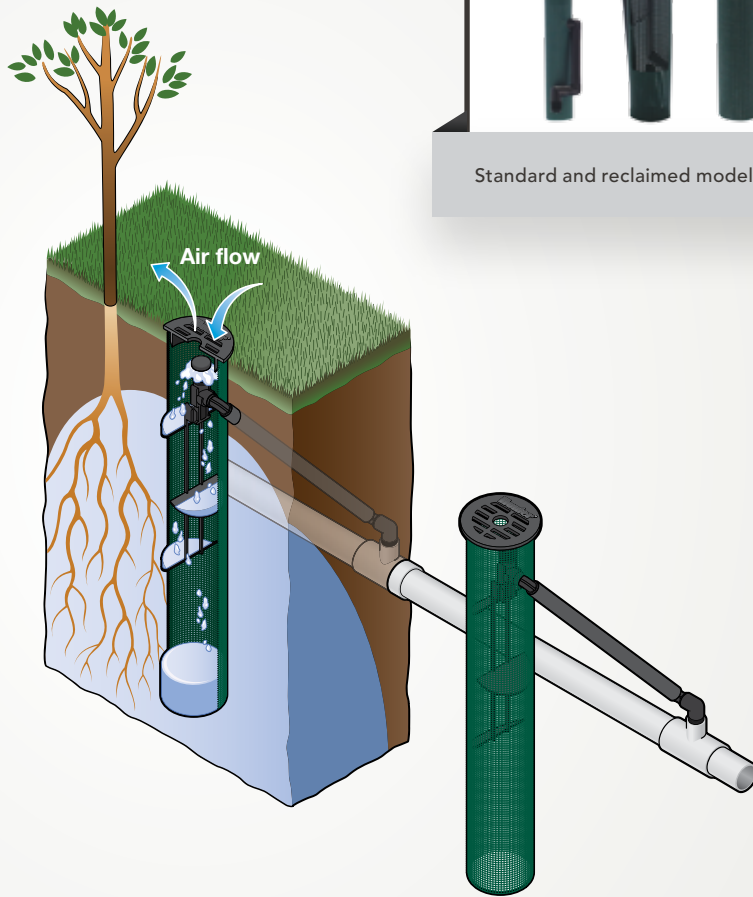

DRIP / MICRO

SPECIFICATIONBUILDER

hunterindustries.com/RZWS

MODELS	BUBBLER FLOW RATE	OPTIONS
RZWS-10 = 10" Root zone watering system	25 = 0.25 GPM 50 = 0.50 GPM	(blank) = No option CV = Check valve R = Reclaimed cap CV-R = Check valve with reclaimed cap
RZWS-18 = 18" Root zone watering system		
RZWS-36 = 36" Root zone watering system		

EXAMPLES

RZWS-18 - 25 - CV	18" Root zone watering system at 0.25 GPM, with check valve
RZWS-10 - 50 - R	10" Root zone watering system at 0.50 GPM, with reclaimed cap
RZWS-36 - 25 - CV	36" Root zone watering system, at 0.25 GPM, with check valve

**ADDITIONAL OPTIONS
SPECIFIED SEPARATELY**

- RZWS-SLEEVE = Field installed sleeve made from filter fabric
- RZWS-CAP = Replacement cap for 18" and 36" models
- RZWS-RCCAP = Reclaimed water replacement cap for 18" and 36" models

ACCESSORIES

THE DISTINCTION IS IN THE DETAILS.

Hunter manufactures a full range of convenient accessories that save both time and money. Finish the job right and maintain Hunter quality throughout all projects.

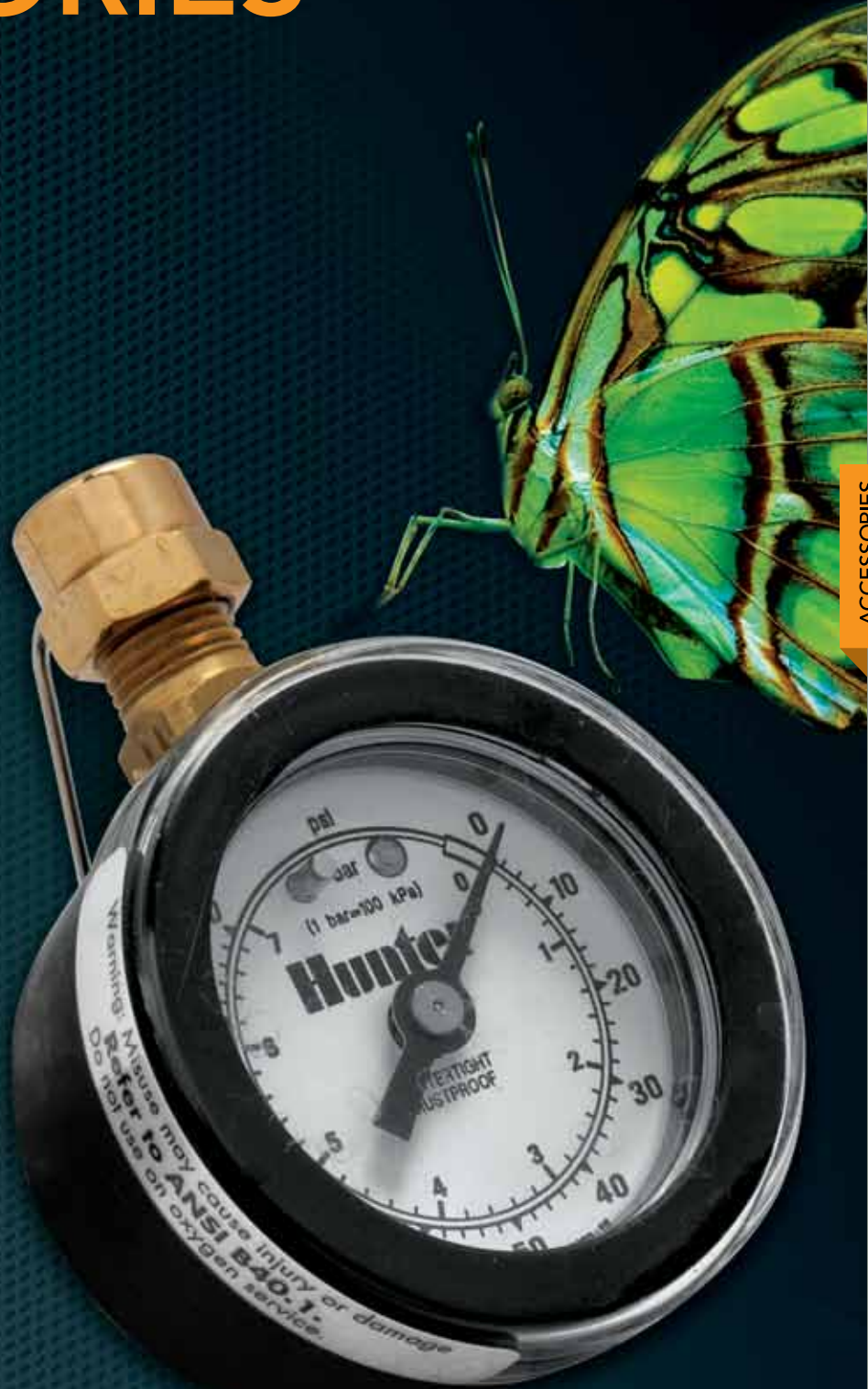

ACCESSORIES

HCV

Models

- HC-50F-50F: ½" Female inlet x ½" Female outlet
- HC-50F-50M: ½" Female inlet x ½" Male outlet
- HC-75F-75M: ¾" Female inlet x ¾" Male outlet

HUNTER SPIRAL BARB ELBOWS

Models

- HSBE-050: ½" male NPT x spiral barb elbow
- HSBE-075: ¾" male NPT x spiral barb elbow
- HSBE TOOL: Insert tool

Features

- For use with FLEX_{SG} Tubing and Hunter Flexible Tubing (HFT-100)
- Acetel material for sharp barbs
- Operating pressure up to 80 PSI
- Compatible with FLEX_{SG}, HFT, and other brands

SJ SWING JOINT

Models

- SJ-506: ½" threaded x 6" length standard
- SJ-506-R: ½" threaded x 6" length retrofit
- SJ-7506: ½" x ¾" threaded x 6" length
- SJ-706: ¾" threaded x 6" length
- SJ-512: ½" threaded x 12" length
- SJ-7512: ½" x ¾" threaded x 12" length
- SJ-712: ¾" threaded x 12" length

Features

- Standard configuration has swivel ells on both ends for maximum versatility
- Retrofit version has a 13/16" hex nut for easy threading into horizontally oriented fittings
- Unique patented swivel ells can be installed to virtually any configuration, leak free
- Pressure rated to 150 PSI

HUNTER FLEXIBLE TUBING

Model

- HFT-100 – 100' roll

Features

- Inside diameter: 0.49"
- Operating pressure: up to 80 PSI
- Linear low-density polyethylene material
- Meets ASTM D2104, D2239, D2737

FLEX_{SG} TUBING

Model

- FLEX_{SG} – 100' roll

Features

- Engineered to resist kinking
- Inside diameter: 0.49"
- Operating pressure: up to 80 PSI
- Linear low-density polyethylene material
- Meets ASTM D2104, D2239, D2737

Pressure loss charts for HCV and SJ products are located on page 127.



HCV: Overall height: 3"



Spiral Barb Elbows:
HSBE-TOOL, HSBE-050, HSBE-075

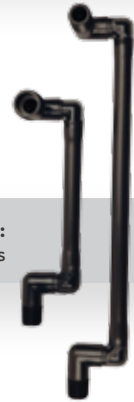

SJ Swing Joint:
6" and 12" links



Hunter Flexible Tubing:
100' roll



FLEX_{SG} Tubing:
100' roll

ACCESSORIES



Hunter Wrench:
P/N 172000



**Rotor Pitot Gauge
and Tube Assembly:**
P/N 280100



Rotor Pressure Gauge:
P/N 129900
(works with PGP-ADJ)



Nozzle Insertion Collar:
P/N 123200



MP Gauge Assembly:
P/N MPGAUGE



MP Tool:
P/N MPTOOL



"T" Handle Tool:
P/N 053191



Hand Pump:
P/N 460302



SpotShot Hose-End Nozzle:
3/4" P/N 160700, 1" P/N 160705

REPLACEMENT GUIDE

Bringing together a combination of intelligent design, carefully controlled manufacturing, and regular testing to ensure conformity to the strictest standards, Hunter has been able to create what performance studies have shown to be truly exceptional nozzles. Essentially, we have made the science of developing superior nozzles—and thus, superior sprinklers—look easy. In the process, we have also made it easy for you to determine exactly which of these high performance sprinklers make the appropriate choice for you to install as an alternative to your current product that does not carry the Hunter label. Simply consult our comprehensive replacement guide and you'll quickly see there's a better quality, better performing sprinkler from Hunter that will fit whatever irrigation need you have.

PGJ Gear Driven Rotary Sprinklers

TO REPLACE		USE HUNTER NOZZLE	
RAIN BIRD®			
		RED	
3500	0.75	.75	
	1	1.0	
	1.5	1.5	
	2	2.0	
	3	3.0	
	4	4	
T-Bird T-22	.65 (Blue)	.75	
	1.0 (Red)	1.0	
	1.3 (Black)	1.5	
	2.0 (Brown)	2.0	
	2.5 (Gray)	2.5	
	4.0 (Yellow)	4.0	
T-Bird T-30	1.0 (Red)	1.0	
	1.3 (Black)	1.5	
	2.0 (Brown)	2.0	
	2.5 (Gray)	2.5	
	4.0 (Yellow)	4.0	
	5.0 (Green)	5.0	
NELSON®			
5500	#51	.75	
	#52	1.5	
	#53	2.0	
	#54	2.5	
TORO®			
300/340	1	.75	
Stream Rotor	2	1.5	
	3	3.0	

PGP® Gear Driven Rotary Sprinklers

TO REPLACE		USE HUNTER NOZZLE		
RAIN BIRD®				
		RED	BLUE	
Mini-Paw 15103	07 (Black)	6	2.5	
	09 (Green)	7	3.0	
Maxi-Paw 2045	06 (Red)	5	2.0	
	07 (Black)	6	2.5	
	08 (Blue)	8	4.0	
	10 (Yellow)	9	5.0	
	12 (Beige)	10	8.0	
R-50	1.5 (Black)	5	2.0	
	2.0 (Brown)	7	3.0	
	3.0 (Gray)	8	4.0	
	4.0 (Yellow)	9	5.0	
	6.0 (Green)	10	8.0	
T-Bird T-30	1.3 (Black)	4	1.5	
	2.5 (Gray)	6	2.5	
	5.0 (Green)	9	5.0	
5000	1.5	4	1.5	
	2.0	5	2.0	
	3.0	7	3.0	
	4.0	8	4.0	
	6.0	9	5.0	
	8.0	10	8.0	
5505	2	5	2.0	
	3	6	2.5	
	4	7	3.0	
	5	8	4.0	
	6	9	5.0	
	8	10	8.0	
	10	10	8.0	
	12	11	8.0	
15111	10 (5/32" nozzle)	9	5.0	
21A, 27A	10 (5/32" nozzle)	9	5.0	
25	10 (5/32" nozzle)	9	5.0	
31A, 37A	14 (7/32" nozzle)	11	8.0	
35	12 (3/16" nozzle)	10	8.0	
K-RAIN				
RPS75	0.50	1	--	
	0.75	2	--	
	1.0	4	1.5	
	2.0	6	2.0	
	2.5	7	2.5	
	3.0	8	3.0	
	4.0	9	4.0	
	6.0	10	6.0	
	8.0	11	8.0	

PGP® Gear Driven Rotary Sprinklers

TO REPLACE		USE HUNTER NOZZLE		
TORO				
		RED	BLUE	
300/340	308-XX-02	4	1.5	
Stream Rotor	308-XX-03	7	3.0	
	316-XX-02	7	3.0	
	316-XX-03	10	8.0	
XP-300 Series	XP-300-090-07	4	1.5	
	180-07	7	3.0	
	360-07	10	8.0	
	XP-300-090-09	5	2.0	
	180-09	8	4.0	
	360-09	11	--	
	XP-300-090-10	5	2.0	
	180-10	9	5.0	
	360-10	12	--	
Super 600	1.3	4	1.5	
	2.5	7	3.0	
	5.0	10	8.0	
	6.0	10	8.0	
Super 700	1.3	3	1.5	
	1.5	4	1.5	
	2.0	5	2.0	
	3.0	7	3.0	
	4.5	8	4.0	
	6.0	9	5.0	
	7.5	10	8.0	
	9.0	11	8.0	
Super 800	0.50	1	--	
	0.75	2	--	
	1.0	4	1.5	
	2.0	6	2.0	
	2.5	7	2.5	
	3.0	8	3.0	
	4.0	9	4.0	
	6.0	10	6.0	
	8.0	11	8.0	
TR50	1.0	3	--	
	1.5	4	1.5	
	2.0	5	2.0	
	3.0	6	3.0	
	4.5	8	4.0	
	6.0	9	6.0	
	7.5	10	8.0	
	9.0	11	8.0	

REPLACEMENT GUIDE

PGP Ultra/I-20 Gear Driven Rotary Sprinklers

TO REPLACE	USE HUNTER NOZZLE	
RAIN BIRD®		
		BLUE
Mini-Paw 15103	07 (Black)	2.5
	09 (Green)	3.0
Maxi-Paw 2045	06 (Red)	2.0
	07 (Black)	2.5
	08 (Blue)	4.0
	10 (Yellow)	5.0
	12 (Beige)	8.0
R-50	1.5 (Black)	2.0
	2.0 (Brown)	3.0
	3.0 (Gray)	4.0
	4.0 (Yellow)	5.0
	6.0 (Green)	8.0
T-Bird T-30	1.3 (Black)	1.5
	2.5 (Gray)	2.5
	5.0 (Green)	5.0
5000	1.5	1.5
	2.0	2.0
	3.0	3.0
	4.0	4.0
	6.0	5.0
	8.0	8.0
5505	2	2.0
	3	2.5
	4	3.0
	5	4.0
	6	5.0
	8	8.0
	10	8.0
	12	8.0
15111	10 (5/32" nozzle)	5.0
21A, 27A	10 (5/32" nozzle)	5.0
25	10 (5/32" nozzle)	5.0
31A, 37A	14 (7/32" nozzle)	8.0
35	12 (3/16" nozzle)	8.0
K-RAIN		
		BLUE
RPS75	0.50	--
	0.75	--
	1.0	1.5
	2.0	2.0
	2.5	2.5
	3.0	3.0
	4.0	4.0
	6.0	6.0
	8.0	8.0

PGP Ultra/I-20 Gear Driven Rotary Sprinklers

TO REPLACE	USE HUNTER NOZZLE	
TORO		
		BLUE
300 / 340	308-XX-02	1.5
Stream Rotor	308-XX-03	3.0
	316-XX-02	3.0
	316-XX-03	8.0
XP-300 Series	XP-300-090-07	1.5
	180-07	3.0
	360-07	8.0
	XP-300-090-09	2.0
	180-09	4.0
	360-09	--
	XP-300-090-10	2.0
	180-10	5.0
	360-10	--
Super 600	1.3	1.5
	2.5	3.0
	5.0	8.0
	6.0	8.0
Super 700	1.3	1.5
	1.5	1.5
	2.0	2.0
	3.0	3.0
	4.5	4.0
	6.0	5.0
	7.5	8.0
	9.0	8.0
Super 800	0.50	--
	0.75	--
	1.0	1.5
	2.0	2.0
	2.5	2.5
	3.0	3.0
	4.0	4.0
	6.0	6.0
	8.0	8.0
TR50	1.0	--
	1.5	1.5
	2.0	2.0
	3.0	3.0
	4.5	4.0
	6.0	6.0
	7.5	8.0
	9.0	8.0

Spray Sprinklers

TO REPLACE	USE HUNTER PRODUCT	
ALL MANUFACTURERS NOZZLES		
		NOZZLES
Nozzles	8' Radius	8A
	10' Radius	10A
	12' Radius	12A
	15' Radius	15A
	17' Radius	17A
Rain Bird 1800		PRO-SPRAY
1800 SAM		PRO-SPRAY-CV
1800 SAM PRS		PRO-SPRAY-PRS30-CV
Uni-Spray		PS ULTRA

REPLACEMENT GUIDE

I-25 Gear Driven Rotary Sprinklers

TO REPLACE		USE HUNTER NOZZLE
RAIN BIRD®		
FALCON	4 (Black)	4 (YELLOW)
	6 (Lt. Blue)	5 (WHITE)
	8 (Dk. Green)	7 (ORANGE)
	10 (Gray)	8 (LT. BROWN)
	12 (Beige)	10 (LT. GREEN)
	14 (Lt. Green)	13 (LT. BLUE)
	16 (Dk. Brown)	18 (RED)
	18 (Dk. Blue)	20 (DK. BROWN)
41-51A	18 x 11.5	20 (DK. BROWN)
41-51A	13 x 11	13 (LT. BLUE)
47A	16	13 (LT. BLUE)
37A	14	8 (LT. BROWN)
7005	4 (Black)	4 (YELLOW)
	6 (Lt. Blue)	5 (WHITE)
	8 (Dk. Green)	8 (LT. BROWN)
	10 (Gray)	10 (LT. GREEN)
	12 (Beige)	13 (LT. BLUE)
	14 (Lt. Green)	15 (GRAY)
	16 (Dk. Brown)	18 (RED)
	18 (Dk. Blue)	20 (DK. BROWN)
8005	12 (Beige)	13 (LT. BLUE)
	14 (Lt. Green)	15 (GRAY)
	16 (Dk. Brown)	18 (RED)
	18 (Dk. Blue)	20 (DK. BROWN)
	20 (Red)	23 (DK. GREEN)
	22 (Yellow)	25 (DK. BLUE)
	24 (Orange)	28 (BLACK)
Toro®		
2001	6 (Yellow)	7 (ORANGE)
	9 (Red)	8 (LT. BROWN)
	12 (Brown)	10 (LT. GREEN)
	18 (Blue)	18 (RED)
	24 (Green)	25 (DK. BLUE)
640	40	8 (LT. BROWN)
	41	10 (LT. GREEN)
	42	13 (LT. BLUE)
	43	15 (GRAY)
	44	20 (DK. BROWN)
NELSON®		
7000 & 7500	1	7 (ORANGE)
	2	8 (LT. BROWN)
	3	10 (LT. GREEN)
	4	13 (LT. BLUE)
	5	15 (GRAY)
	6	20 (DK. BROWN)
	7	23 (DK. GREEN)
	8	25 (DK. BLUE)
THOMPSON®		
186/187	P-Nozzle	5 (WHITE)
	Q-Nozzle	7 (ORANGE)
	R-Nozzle	13 (LT. BLUE)
	S-Nozzle	15 (GRAY)
	T-Nozzle	18 (RED)
	U-Nozzle	23 (DK. GREEN)
	VS-Nozzle	28 (BLACK)
	V-Nozzle	28 (BLACK)
	W-Nozzle	28 (BLACK)
SINGLE NOZZLE		ALL IMPACT MFRS
	5/32"	4 (YELLOW)
	11/64"	5 (WHITE)
	3/16"	7 (ORANGE)
	13/64"	8 (LT. BROWN)
	7/32"	10 (LT. GREEN)
	15/64"	13 (LT. BLUE)
	1/4"	15 (GRAY)
	17/64"	20 (DK. BROWN)

I-35 Gear Driven Rotary Sprinklers

TO REPLACE		USE HUNTER NOZZLE
TORO		
2001	9 (Red)	9 (LT. BROWN)
	18 (Blue)	18 (RED)
	24 (Green)	24 (DK. BLUE)
640	40	9 (LT. BROWN)
	42	12 (LT. BLUE)
	43	15 (GRAY)
	44	21 (DK. BROWN)
NELSON®		
7000 & 7500	2	9 (LT. BROWN)
	4	12 (LT. BLUE)
	5	15 (GRAY)
	6	21 (DK. BROWN)
	7	24 (DK. GREEN)
	8	27 (DK. BLUE)
THOMPSON®		
186/187	R-Nozzle	12 (LT. BLUE)
	S-Nozzle	15 (GRAY)
	T-Nozzle	18 (RED)
	U-Nozzle	24 (DK. GREEN)
	VS-Nozzle	30 (BLACK)
	V-Nozzle	30 (BLACK)
	W-Nozzle	30 (BLACK)
SINGLE NOZZLE		ALL IMPACT MFRS
	13/64"	9 (LT. BROWN)
	15/64"	12 (LT. BLUE)
	1/4"	15 (GRAY)
	17/64"	21 (DK. BROWN)
RAIN BIRD®		
FALCON	10 (Gray)	9 (LT. BROWN)
	14 (Lt. Green)	12 (LT. BLUE)
	16 (Dk. Brown)	18 (RED)
	18 (Dk. Blue)	21 (DK. BROWN)
41-51A	18 x 11.5	21 (DK. BROWN)
41-51A	13 x 11	12 (LT. BLUE)
47A	16	12 (LT. BLUE)
37A	14	9 (LT. BROWN)
7005	8 (Dk. Green)	9 (LT. BROWN)
	12 (Beige)	12 (LT. BLUE)
	14 (Lt. Green)	15 (GRAY)
	16 (Dk. Brown)	18 (RED)
	18 (Dk. Blue)	21 (DK. BROWN)
8005	12 (Beige)	12 (LT. BLUE)
	14 (Lt. Green)	15 (GRAY)
	16 (Dk. Brown)	18 (RED)
	18 (Dk. Blue)	21 (DK. BROWN)
	20 (Red)	24 (DK. GREEN)
	22 (Yellow)	27 (DK. BLUE)
	24 (Orange)	30 (BLACK)

TECHNICAL

REPLACEMENT GUIDE

I-40 Gear Driven Rotary Sprinklers

TO REPLACE	USE HUNTER NOZZLE	
RAIN BIRD®		
41-51A	18 x 11.5	44
41-51A	13 x 11	43
47A-SAM	16	42
37A	14	41
65 SERIES	16	42
8005	12 (Beige)	41
	14 (Lt. Green)	43
	16 (Dk. Brown)	43
	18 (Dk. Blue)	44
	20 (Red)	44
	22 (Yellow)	45
RAIN BIRD®		
TALON	14	42
	16	43
	18	44
	20	45
	22	45
THOMPSON®		
186/7	R-Nozzle	42
	S-Nozzle	43
	T-Nozzle	43
188/9	U-Nozzle	44
	V-Nozzle	45
TORO®		
640	USE HUNTER 40-44	
SINGLE NOZZLE	ALL IMPACT MFRS	
	15/64"	41
	1/4"	42
	17/64"	43
	9/32"	43

HQ-Quick Couplers

TO REPLACE				USE HUNTER HQ
RAIN BIRD®	TORO®	BUCKNER	WEST AG/STORM	
3RC	075-SLSC	QB3RC07	4V075-RY, QCV075-R	HQ-3RC
33DRC		QB33RC07	4V133-4A-RY, QCV133-4A-R	HQ-33DRC
33DLRC		QB33LRC07	4V133-4A-RLY, QCV133-4A-RL-2	HQ-33DLRC
33DNP		QB33NP07	4V133-4A-RL-NP, QVC133-4A-N-2	HQ-33DLRC-R
44RC	100-SLSC, 100-2SLVC	QB44RC10	4V144-RY, QCV-144-R	HQ-44RC
44LRC	100-SLVLC	QB44LRC10	4V144-RLY, QCV-144-RL	HQ-44LRC
44NP	100-2SLLVC	QB44NO10	4V144-RL-NP, QCV-144-N	HQ-44LRC-R
		QB44RCATAR10		HQ-44RC-AW
		QB44LRCATAR10		HQ-44LRC-AW
4NP-Acme	100-ATLVC	QB44NPATAR10		HQ-44LRC-AW-R
5RC		QBRB5RC10	4V101-RY, QCV-101-R	HQ-5RC
5LRC		QBRB5LRC10	4V101-RLY, QCV-101-RL	HQ-5LRC
5NP		QBRB5NP10	4V101-RL-NP, QCV-101-N	HQ-5LRC-R
5RC-BSP		QBRB5RC10BS	4V101-RY-BS, QCV-101-R-BS	HQ-5RC-BSP
5LRC-BSP		QBRB5LRC10BS	4V101-RLY-BS, QCV-101-RL-BS	HQ-5LRC-BSP
5NP-BSP		QBRB5NP10BS	4V101-RL-NP-BS, QCV-101-N-BS	HQ-5LRC-BSPR

HK-Keys

TO REPLACE				USE HUNTER HK
RAIN BIRD®	TORO®	BUCKNER	WEST AG/STORM	
33K, 33DK	075-SLK	QB33K07	4C075, C075	HK-33
44K	100-SLK	QB44K10	4C100, C100	HK-44
4K-Acme	100-AK	QB44KAT10	4C100A, C100A	HK-44A
55K-1		QB5RK10	4C101, C101	HK-55

HS-Swivels

TO REPLACE				USE HUNTER HS
RAIN BIRD®	TORO®	BUCKNER	WEST AG/STORM	
SH-0	075-75MHS	HS075	4HS-075, HS075	HS-0
SH-1	075-MHS	HS100	4HS-100, HS-100	HS-1
SH-2	100-MHS	HS101	4HS-101, HS-101	HS-2
		HS100BS	4HS-100-BS, HS-100-BS	HS-1-B
		HS101BS	4HS-101-BS, HS-101-BS	HS-2-B

HQ-Pressure Loss Chart (PSI)

Flow - GPM	HQ-3	HQ-33	HQ-44	HQ-5
5	0.8	1.0		
10	1.8	2.0		
15	4.1	4.3	2.2	
20	7.2	7.6	4.4	1.0
30			11.5	3.0
40				6.3
50				9.2
60				13.0
70				19.8

PRECIPITATION RATES

A brief overview for the irrigation professional on how to calculate this important information.

In this section, the “Sprinkler Spacing Method–Any Arc and Any Spacing” equation is used to calculate precipitation rates. The first set of equations with the ■ shows the precipitation rate for the sprinklers when they are laid out in a square pattern. The next set with the ▲ shows the precipitation rate for the sprinklers laid out in an equilateral triangular spacing pattern. This is the “Sprinkler Spacing Method–Equilateral Triangular Spacing” equation.

WHAT IS “PRECIPITATION RATE”?

If someone said they were caught in a rainstorm that dropped one inch of water in an hour, you would have some idea of how “hard” or “heavily” the rain came down. A rainstorm that covers an area with one inch of water in one hour has a “precipitation rate” of one inch per hour (1 in/hr or 25 mm/hr). Similarly, the precipitation rate is the “speed” at which a sprinkler or an irrigation system applies water.

MATCHED PRECIPITATION RATES

A zone or system in which all the heads have similar precipitation rates is said to have “matched precipitation rates.” Systems that have matched precipitation rates reduce wet and dry spots and excessive run times which lead to high water consumption and increased costs. Knowing that sprinkler spacing,

flow rates, and arcs of coverage affect precipitation rates, a general rule of thumb is: as the spray arc doubles, so should the flow.

■ 90° Arc = 1 GPM
(0.23 m³/hr; 3.8 l/min)

◐ 180° Arc = 2 GPM
(0.45 m³/hr; 7.6 l/min)

● 360° Arc = 4 GPM
(0.91 m³/hr; 15.1 l/min)

The flow rate of half-circle heads must be two times the flow rate of the quarter-circle heads, and the full-circle heads must have two times the flow rate of the half-circle heads. In the illustration, the same amount of water is applied to each quarter circle area and precipitation is therefore matched.

CALCULATING PRECIPITATION RATES

Depending upon the construction of the irrigation system, the precipitation rate may be calculated by either a “sprinkler spacing” or a “total area” method.

<p>Sprinkler Spacing Method The precipitation rate should be calculated for each individual zone. If all sprinkler heads on the zone have the same spacing, flow rate, and arc of coverage, use one of the following formulas:</p>	<p>Any Arc and Any Spacing (■):</p> $\text{P.R. (in/hr)} = \frac{\text{GPM (for any Arc)} \times 34,650}{\text{Degrees of Arc} \times \text{Head Spacing (ft)} \times \text{Row Spacing (ft)}}$ $\text{P.R. (mm/hr)} = \frac{\text{m}^3/\text{hr (for any Arc)} \times 360,000}{\text{Degrees of Arc} \times \text{Head Spacing (m)} \times \text{Row Spacing (m)}}$ $\text{P.R. (mm/hr)} = \frac{\text{l/min (for any Arc)} \times 21,600}{\text{Degrees of Arc} \times \text{Head Spacing (m)} \times \text{Row Spacing (m)}}$ <p>Equilateral Triangular Spacing (▲):</p> $\text{P.R. (in/hr)} = \frac{\text{GPM of 360 Arc} \times 96.25}{(\text{Head Spacing})^2 \times .866}$ $\text{P.R. (mm/hr)} = \frac{\text{m}^3/\text{hr} \times 1,000}{\text{Total Area}}$ $\text{P.R. (mm/hr)} = \frac{\text{l/min of 360 Arc} \times 60}{(\text{Head Spacing})^2 \times .866}$
<p>Total Area Method The precipitation rate for a “system” is the average precipitation rate of all sprinklers in an area, regardless of the spacing, flow rate, or arc for each head. The Total Area Method calculates all the flows of all of the heads in any given area.</p>	$\text{P.R. (in/hr)} = \frac{\text{Total GPM} \times 96.25}{\text{Total Area}}$ $\text{P.R. (mm/hr)} = \frac{\text{m}^3/\text{hr} \times 1,000}{\text{Total Area}}$ $\text{P.R. (mm/hr)} = \frac{\text{l/min} \times 60}{\text{Total Area}}$

For more information on precipitation rates, visit www.hunterindustries.com/mpbasics

SLOPE EQUIVALENTS/IRRIGATION

Percent, Angle, and Ratio

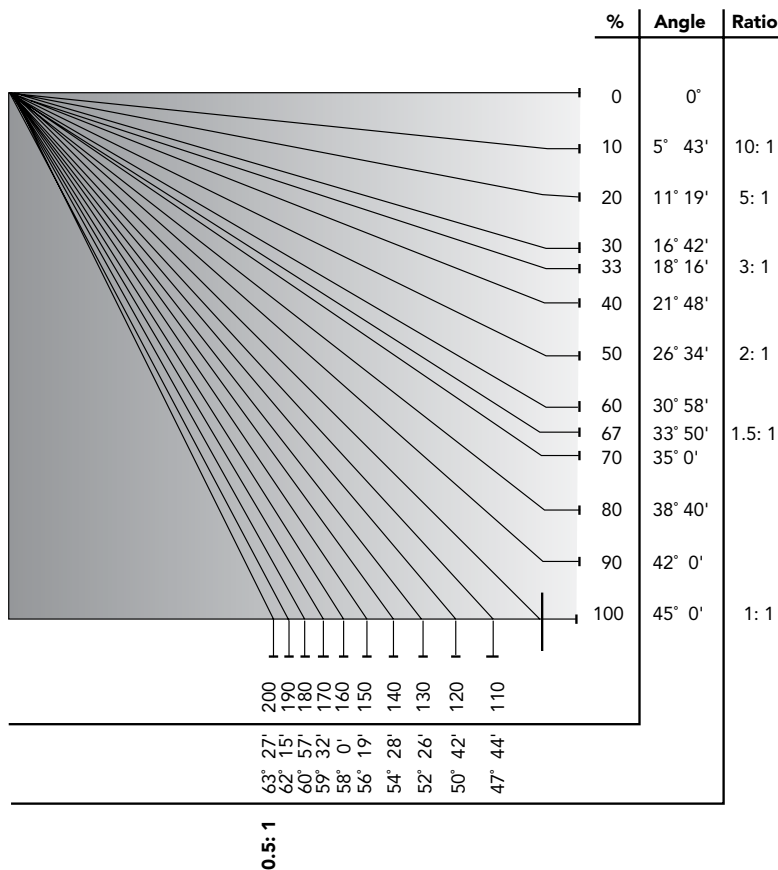

Slope Irrigation

Maximum precipitation rates for slopes.

The maximum precipitation values listed below are those suggested by the United States Department of Agriculture. The values are average and may vary with respect to actual soil condition and condition of ground cover.

SOIL TEXTURE	0 to 5% slope		5 to 8% slope		8 to 12% slope		12% + slope	
	Cover	Bare	Cover	Bare	Cover	Bare	Cover	Bare
Coarse sandy soils	2.00	2.00	2.00	1.50	1.50	1.00	1.00	0.50
Coarse sandy soils over compact subsoils	1.75	1.50	1.25	1.00	1.00	0.75	0.75	0.40
Light sandy loams uniform	1.75	1.00	1.25	0.80	1.00	0.60	0.75	0.40
Light sandy loams over compact subsoils	1.25	0.75	1.00	0.50	0.75	0.40	0.50	0.30
Uniform silt loams	1.00	0.50	0.80	0.40	0.60	0.30	0.40	0.20
Silt loams over compact subsoil	0.60	0.30	0.50	0.25	0.40	0.15	0.30	0.10
Heavy clay or clay loam	0.2	0.15	0.15	0.1	0.12	0.08	0.1	0.06

HEIGHT OF SPRAY

The trajectory and spray height of the water stream leaving a sprinkler nozzle is important information when designing and installing irrigation systems.

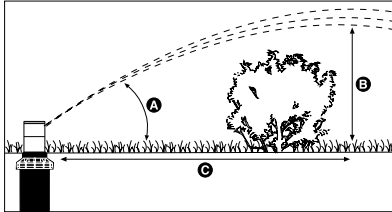

These rotor nozzle trajectory charts are designed to help determine how close a sprinkler can be placed to an object such as a fence or hedge without obstructing the spray pattern. All information shown is at optimum operating pressures.

Model	Nozzle No.	Pressure in PSI	A Degrees of Trajectory	B Max Height of Spray	C Distance from head (ft.) to Maximum Height
MP Rotator	3000	40	26	79"	Varies
	2000	40	26	45"	Varies
	1000	40	20	20"	Varies
	Corner	40	14	14"	Varies
	Side Strip	40	16	19"	Varies
	Left Strip	40	16	18"	Varies
PGJ	.75	40	10	2'	4'
	1.0	40	10	2'	8'
	1.5	40	10	3'	12'
	2.0	40	15	5'	16'
	2.5	40	12	5'	20'
	3.0	40	15	5'	20'
	4.0	40	15	5'	22'
	5.0	40	15	6'	24'
PGP® Red Nozzles	1	50	26	7'	22'
	2	50	26	7'	22'
	3	50	26	8'	23'
	4	50	26	8'	23'
	5	50	27	9'	26'
	6	50	27	10'	28'
	7	50	26	11'	30'
	8	50	26	11'	30'
	9	50	27	12'	32'
	10	60	25	13'	32'
	11	60	25	13'	38'
	12	60	25	13'	40'
PGP Low Angle Gray Nozzles	4	50	15	5'	22'
	5	50	15	4'	22'
	6	50	14	4'	22'
	7	50	14	4'	22'
	8	50	14	5'	24'
	9	50	15	5'	26'
PGP Blue Nozzles	1.5	45	25	8'	23'
	2.0	45	25	8'	23'
	2.5	45	25	9'	26'
	3.0	45	25	10'	28'
	4.0	45	25	11'	30'
	5.0	45	25	11'	30'
	6.0	55	25	12'	32'
	8.0	55	25	13'	32'
PGP Ultra/I-20 Dark Blue Nozzles	1.0	50	26	8'	23'
	1.5	50	26	8'	23'
	2.0	50	27	9'	26'
	3.0	50	27	10'	28'
	3.5	50	26	11'	30'
	4.0	50	26	11'	30'
	6.0	50	27	12'	32'
	8.0	60	25	13'	32'
PGP Ultra/I-20 Blue Nozzles	1.5	45	25	8'	23'
	2.0	45	25	8'	23'
	2.5	45	25	9'	26'
	3.0	45	25	10'	28'
	4.0	45	25	11'	30'
	5.0	45	25	11'	30'
	6.0	55	25	12'	32'
	8.0	55	25	13'	32'

TECHNICAL

HEIGHT OF SPRAY

Hunter Nozzle Height and Trajectory Chart					
Model	Nozzle No.	Pressure in PSI	A Degrees of Trajectory	B Max Height of Spray (ft.)	C Distance from head (ft.) to Maximum Height
PGP Ultra/I-20 Low Angle Gray Nozzles	2.0LA	50	13	5	22
	2.5LA	50	13	4	22
	3.5LA	50	13	4	22
	4.5LA	50	13	4	22
PGP Ultra/I-20 Short Radius Black Nozzles	.50	50	15	5	8
	1.0	50	14	6	9
	2.0	50	3	1	6
PGP Ultra/I-20 Short Radius Black Nozzles	.75	50	22	7	13
	1.5	50	18	7	13
	3.0	50	8	1	6
I-25	4	50	25	9	22
	5	50	25	11	28
	7	50	25	10	28
	8	50	25	11	28
	10	60	25	12	30
	13	60	25	13	31
	15	60	25	12	31
	18	60	25	15	34
	20	70	25	15	35
	23	70	25	16	38
25	70	25	16	38	
28	70	25	17	40	
I-35	9	50	25	11	28
	12	60	25	13	31
	15	60	25	12	31
	18	60	25	15	34
	21	70	25	15	35
	24	70	25	16	38
	27	70	25	16	38
30	70	25	17	40	
I-40	40	50	25	12	32
	41	60	25	14	32
	42	60	25	14	34
	43	60	25	15	42
	44	70	25	17	46
45	70	25	17	48	
I-60 ADS	7	60	20	10	28
	10	60	20	13	38
	13	60	20	13	38
	15	60	20	14	40
	18	60	20	14	40
20	60	20	15	46	
I-60 36S	7	60	20	13	36
	10	60	20	14	40
	13	60	20	14	41
	15	60	20	14	42
	18	60	20	14	43
20	60	20	17	50	
I-90 ADV	33	80	22	15	42
	38	80	22	16	48
	43	80	22	16	48
	48	80	22	17	54
	53	80	22	17	56
63	80	22	18	64	
I-90 36V	33	80	22	17	46
	38	80	22	17	50
	43	80	22	17	54
	48	80	22	17	56
	53	80	22	17	58
63	80	22	18	62	

17 MM PLD CHARTS

PLD APPLICATION RATES

Emitter Flow Rate – 1.0 GPH				Emitter Flow Rate – 0.6 GPH				Emitter Flow Rate – 0.4 GPH			
Row Spacing (in)	Emitter Spacing (in)			Row Spacing (in)	Emitter Spacing (in)			Row Spacing (in)	Emitter Spacing (in)		
	12	18	24		12	18	24		12	18	24
12	1.60	1.07	0.80	12	0.96	0.64	0.48	12	0.64	0.43	0.32
14	1.38	0.92	0.69	14	0.83	0.55	0.41	14	0.55	0.37	0.28
16	1.20	0.80	0.60	16	0.72	0.48	0.36	16	0.48	0.32	0.24
18	1.07	0.71	0.53	18	0.64	0.43	0.32	18	0.43	0.29	0.21
20	0.96	0.64	0.48	20	0.58	0.39	0.29	20	0.39	0.26	0.19
24	0.80	0.53	0.40	24	0.48	0.32	0.24	24	0.32	0.21	0.16

PLD application rates in inches per hour

PLD EMITTER LINE MAXIMUM LENGTH CHARTS

Emitter Line Length – 0.4 GPM				Emitter Line Length – 0.6 GPM				Emitter Line Length – 1.0 GPM			
Pressure (PSI)	Emitter Spacing (in)			Pressure (PSI)	Emitter Spacing (in)			Pressure (PSI)	Emitter Spacing (in)		
	12	18	24		12	18	24		12	18	24
15.0	289	401	502	15.0	173	240	300	15.0	126	176	222
20.0	354	494	620	20.0	230	320	402	20.0	169	235	295
25.0	405	563	706	25.0	265	373	471	25.0	197	276	346
30.0	441	621	783	30.0	299	417	523	30.0	218	308	390
35.0	481	671	842	35.0	333	462	580	35.0	240	337	425
40.0	508	719	910	40.0	342	483	611	40.0	263	362	452
45.0	542	755	949	45.0	364	518	657	45.0	271	384	486
50.0	558	784	988	50.0	387	543	685	50.0	288	401	503

PLD FLOW CONVERSION CHARTS

Quick Reference Chart – GPM per 100'

Emitter (GPH)	12"	18"	24"
0.4	0.67	0.44	0.33
0.6	1.00	0.67	0.50
1.0	1.67	1.11	0.83

TECHNICAL

DRIP ZONE CONTROL KIT CHARTS

ICZ101, PCZ101, ACZ075

Inlet pressure required for designed outlet pressure

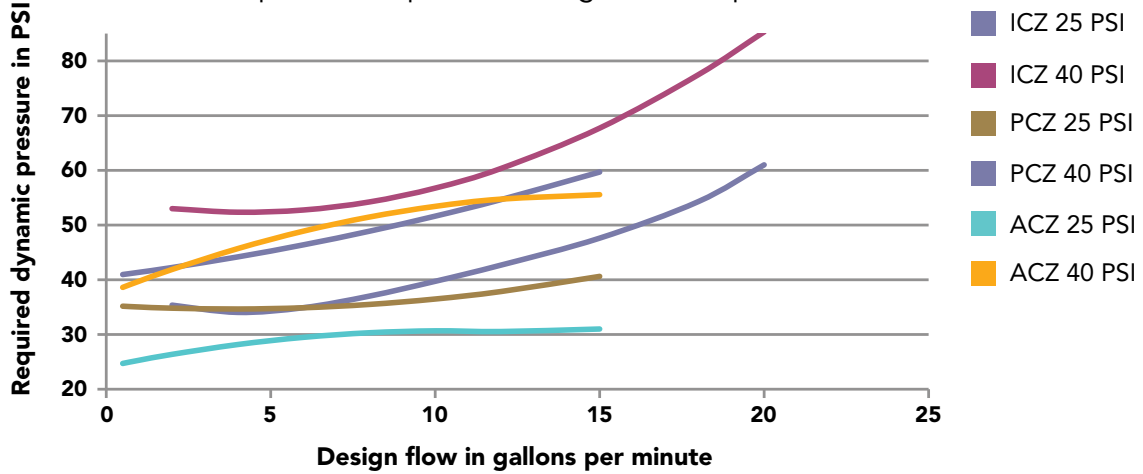

ICZ151

Inlet pressure required for designed outlet pressure

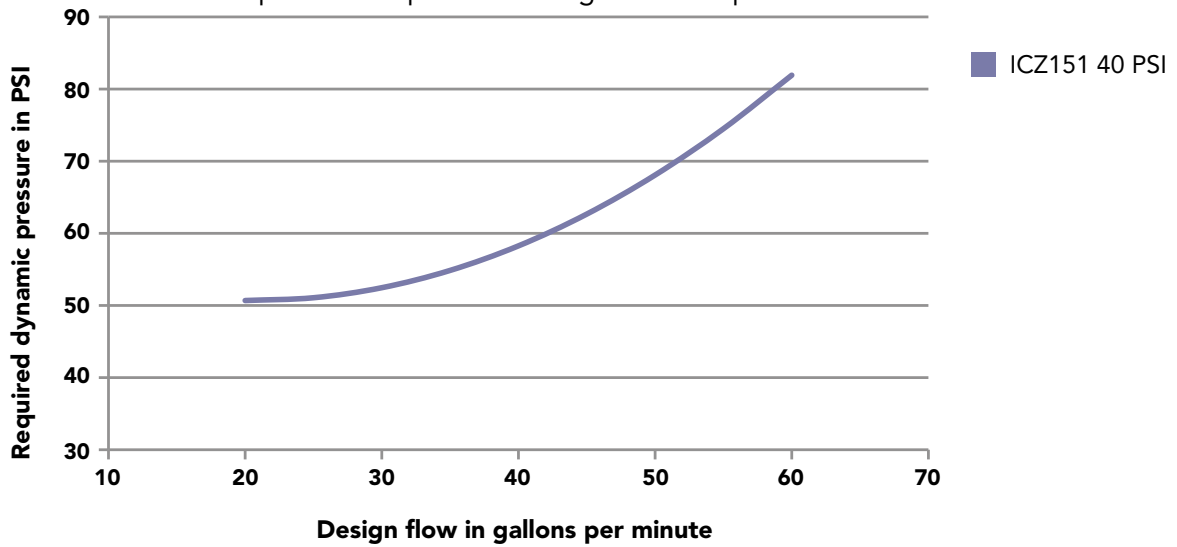

CONVERSION FACTORS

To Convert	From	To	Multiply By
AREA	acres	foot ²	43560
	acres	meter ²	4046.8
	meter ²	foot ²	10.764
	foot ²	inch ²	144
	inch ²	centimeter ²	6.452
	hectares	meter ²	10000
	hectares	acres	2.471
POWER	kilowatts	horsepower	1.341
FLOW	foot ³ /minute	meter ³ /second	0.0004719
	foot ³ /second	meter ³ /second	0.02832
	yards ³ /minute	meter ³ /second	0.01274
	gallon/minute	meter ³ /hour	0.22716
	gallon/minute	liter/minute	3.7854
	gallon/minute	liter/second	0.06309
	meter ³ /hour	liter/minute	16.645
	meter ³ /hour	liter/second	0.2774
	liter/minute	liter/second	60
LENGTH	foot	inch	12
	inch	centimeter	2.540
	foot	meter	0.30481
	kilometer	miles	0.6214
	miles	foot	5280
	miles	meter	1609.34
	millimeter	inch	0.03937
PRESSURE	PSI	kilopascals	6.89476
	PSI	bar	0.068948
	bar	kilopascals	100
	PSI	feet of head	2.31
VELOCITY	feet/second	meter/second	0.3048
VOLUME	feet ³	gallon	7.481
	feet ³	liter	28.32
	meter ³	feet ³	35.31
	meter ³	yard ³	1.3087
	yard ³	feet ³	27
	yard ³	gallon	202
	acres/feet	foot ³	43,560
	gallon	meter ³	0.003785
	gallon	liter	3.785
	imperial gallon	gallon	1.833

TECHNICAL

PRESSURE LOSS CHART

WATER METER PRESSURE LOSS CHART TYPICAL PRESSURE LOSSES (PSI)

Flow GPM	Nominal Size						Flow GPM	
	5/8"	3/4"	1"	1-1/2"	2"	3"		4"
1	0.2	0.1						1
2	0.3	0.2						2
3	0.4	0.3						3
4	0.6	0.5	0.1					4
5	0.9	0.6	0.2					5
6	1.3	0.7	0.3					6
7	1.8	0.8	0.4					7
8	2.3	1.0	0.5					8
9	3.0	1.3	0.6					9
10	3.7	1.6	0.7					10
11	4.4	1.9	0.8					11
12	5.1	2.2	0.9					12
13	6.1	2.6	1.0					13
14	7.2	3.1	1.1					14
15	8.3	3.6	1.2					15
16	9.4	4.1	1.4	0.4				16
17	10.7	4.6	1.6	0.5				17
18	12.0	5.2	1.8	0.6				18
19	13.4	5.8	2.0	0.7				19
20	15.0	6.5	2.2	0.8				20
22		7.9	2.8	1.0				22
24		9.5	3.4	1.2				24
26		11.2	4.0	1.4				26
28		13.0	4.6	1.6				28
30		15.0	5.3	1.8	0.7			30
32			6.0	2.1	0.8			32
34			6.9	2.4	0.9			34
36			7.8	2.7	1.0			36
38			8.7	3.0	1.2			38
40			9.6	3.3	1.3			40
42			10.6	3.6	1.4			42
44			11.7	3.9	1.5			44
46			12.8	4.2	1.6			46
48			13.9	4.5	1.7			48
50			15.0	4.9	1.9			50
52				5.3	2.1			52
54				5.7	2.2			54
56				6.2	2.3			56
58				6.7	2.5			58
60				7.2	2.7	1.0		60
65				8.3	3.2	1.1		65
70				9.8	3.7	1.3		70
75				11.3	4.3	1.5		75
80				12.8	4.9	1.6	0.7	80
90				16.1	6.2	2.0	0.8	90
100				20.0	7.8	2.5	0.9	100
110					9.5	2.9	1.0	110
120					11.3	3.4	1.2	120
130					13.0	3.9	1.4	130
140					15.1	4.5	1.6	140
150					17.3	5.1	1.8	150
160					20.0	5.8	2.1	160
170						6.5	2.4	170
180						7.2	2.7	180
190						8.0	3.0	190
200						9.0	3.2	200
220						11.0	3.9	220
240						13.0	4.7	240
260						15.0	5.5	260
280						17.3	6.3	280
300						20.0	7.2	300
350							10.0	350
400							13.0	400
450							16.2	450
500							20.0	500
	Shaded areas represent velocities over 5 fps. Use with caution where water hammer is a concern.							
75% of Max Meter Capacity	15 GPM	22.5 GPM	37.5 GPM	75 GPM	120 GPM	225 GPM	375 GPM	75% of Max Meter Capacity

FRICITION LOSS CHARTS

Irrigation Association Friction Loss Chart 2008

TYPE K COPPER TUBING

ASTM B 88 C=140 • PSI LOSS PER 100 FEET OF PIPE

Nominal Size	1/2"		5/8"		3/4"		1"		1-1/4"		1-1/2"		2"		2-1/2"		3"	
Pipe ID	0.527		0.652		0.745		0.995		1.245		1.481		1.959		2.435		2.907	
Pipe OD	0.625		0.750		0.875		1.125		1.375		1.625		2.125		2.625		3.125	
Avg. Wall	0.049		0.049		0.065		0.065		0.065		0.072		0.083		0.095		0.109	
Flow GPM	Velocity FPS	PSI LOSS	Velocity FPS	PSI LOSS	Velocity FPS	PSI LOSS	Velocity FPS	PSI LOSS	Velocity FPS	PSI LOSS	Velocity FPS	PSI LOSS	Velocity FPS	PSI LOSS	Velocity FPS	PSI LOSS	Velocity FPS	PSI LOSS
1	1.47	1.09	0.96	0.39	0.74	0.20	0.41	0.05	0.26	0.02								
2	2.94	3.94	1.92	1.40	1.47	0.73	0.82	0.18	0.53	0.06								
3	4.41	8.35	2.88	2.97	2.21	1.55	1.24	0.38	0.79	0.13								
4	5.88	14.23	3.84	5.05	2.94	2.64	1.65	0.65	1.05	0.22								
5	7.35	21.51	4.80	7.64	3.68	3.99	2.06	0.98	1.32	0.33								
6	8.81	30.15	5.76	10.70	4.41	5.59	2.47	1.37	1.58	0.46	1.12	0.20						
7	10.28	40.12	6.72	14.24	5.15	7.44	2.88	1.82	1.84	0.61	1.30	0.26						
8	11.75	51.37	7.68	18.24	5.88	9.53	3.30	2.33	2.11	0.78	1.49	0.34						
9	13.22	63.90	8.64	22.68	6.62	11.85	3.71	2.90	2.37	0.97	1.67	0.42						
10	14.69	77.66	9.60	27.57	7.35	14.41	4.12	3.52	2.63	1.18	1.86	0.51						
12			11.52	38.64	8.82	20.20	4.95	4.94	3.16	1.66	2.23	0.71	1.28	0.18				
14			13.44	51.41	10.29	26.87	5.77	6.57	3.69	2.21	2.60	0.95	1.49	0.24				
16			15.36	65.83	11.76	34.41	6.59	8.42	4.21	2.83	2.98	1.22	1.70	0.31				
18			17.28	81.88	13.23	42.80	7.42	10.47	4.74	3.52	3.35	1.51	1.91	0.39				
20					14.70	52.02	8.24	12.72	5.26	4.28	3.72	1.84	2.13	0.47				
22					16.17	62.06	9.07	15.18	5.79	5.10	4.09	2.19	2.34	0.56	1.51	0.19	1.06	0.08
24					17.64	72.91	9.89	17.84	6.32	5.99	4.46	2.58	2.55	0.66	1.65	0.23	1.16	0.10
26							10.71	20.69	6.84	6.95	4.84	2.99	2.76	0.77	1.79	0.27	1.26	0.11
28							11.54	23.73	7.37	7.97	5.21	3.43	2.98	0.88	1.93	0.30	1.35	0.13
30							12.36	26.96	7.90	9.06	5.58	3.89	3.19	1.00	2.06	0.35	1.45	0.15
32							13.19	30.39	8.42	10.21	5.95	4.39	3.40	1.12	2.20	0.39	1.54	0.16
34							14.01	34.00	8.95	11.42	6.32	4.91	3.61	1.26	2.34	0.44	1.64	0.18
36							14.84	37.79	9.48	12.70	6.70	5.46	3.83	1.40	2.48	0.49	1.74	0.20
38							15.66	41.77	10.00	14.04	7.07	6.03	4.04	1.55	2.61	0.54	1.83	0.23
40							16.48	45.94	10.53	15.43	7.44	6.63	4.25	1.70	2.75	0.59	1.93	0.25
42							17.31	50.28	11.06	16.89	7.81	7.26	4.47	1.86	2.89	0.65	2.03	0.27
44									11.58	18.41	8.18	7.91	4.68	2.03	3.03	0.70	2.12	0.30
46									12.11	19.99	8.56	8.59	4.89	2.20	3.17	0.76	2.22	0.32
48									12.63	21.63	8.93	9.30	5.10	2.38	3.30	0.83	2.32	0.35
50									13.16	23.33	9.30	10.03	5.32	2.57	3.44	0.89	2.41	0.38
55									14.48	27.84	10.23	11.96	5.85	3.07	3.78	1.06	2.66	0.45
60									15.79	32.70	11.16	14.05	6.38	3.60	4.13	1.25	2.90	0.53
65									17.11	37.93	12.09	16.30	6.91	4.18	4.47	1.45	3.14	0.61
70									18.43	43.51	13.02	18.70	7.44	4.79	4.82	1.66	3.38	0.70
75											13.95	21.24	7.97	5.45	5.16	1.89	3.62	0.80
80											14.88	23.94	8.51	6.14	5.50	2.13	3.86	0.90
85											15.81	26.79	9.04	6.87	5.85	2.38	4.10	1.01
90											16.74	29.78	9.57	7.63	6.19	2.65	4.35	1.12
95											17.67	32.91	10.10	8.44	6.54	2.93	4.59	1.24
100											18.60	36.19	10.63	9.28	6.88	3.22	4.83	1.36
110													11.69	11.07	7.57	3.84	5.31	1.62
120													12.76	13.01	8.26	4.51	5.79	1.91
130													13.82	15.08	8.95	5.23	6.28	2.21
140													14.88	17.30	9.63	6.00	6.76	2.54
150													15.95	19.66	10.32	6.82	7.24	2.88
160													17.01	22.16	11.01	7.69	7.72	3.25
170													18.07	24.79	11.70	8.60	8.21	3.63
180															12.39	9.56	8.69	4.04
190															13.07	10.57	9.17	4.46
200															13.76	11.62	9.66	4.91
220															15.14	13.87	10.62	5.86
240															16.51	16.29	11.59	6.88
260															17.89	18.90	12.55	7.98
280															19.27	21.68	13.52	9.15
300																	14.48	10.40
320																	15.45	11.72
340																	16.42	13.11
360																	17.38	14.58
380																	18.35	16.11
400																		
420																		
440																		
460																		
480																		
500																		

Shaded area represents velocities over 7 fps.
Use with caution where water hammer is a concern.

TECHNICAL

FRICION LOSS CHARTS

Irrigation Association Friction Loss Chart 2008

TYPE L COPPER TUBING

C=140 • PSI LOSS 100 FEET OF PIPE

Nominal Size Pipe ID Pipe OD Avg. Wall	1/2"		5/8"		3/4"		1"		1-1/4"		1-1/2"		2"		2-1/2"		3"	
	Velocity FPS	PSI LOSS	Velocity FPS	PSI LOSS	Velocity FPS	PSI LOSS	Velocity FPS	PSI LOSS	Velocity FPS	PSI LOSS	Velocity FPS	PSI LOSS	Velocity FPS	PSI LOSS	Velocity FPS	PSI LOSS	Velocity FPS	PSI LOSS
1	1.37	0.93	0.92	0.35	0.66	0.16	0.39	0.04	0.25	0.02								
2	2.75	3.35	1.84	1.26	1.32	0.57	0.78	0.15	0.51	0.06								
3	4.12	7.09	2.76	2.67	1.99	1.20	1.17	0.33	0.76	0.12								
4	5.49	12.09	3.68	4.56	2.65	2.05	1.55	0.56	1.02	0.20								
5	6.87	18.27	4.60	6.89	3.31	3.09	1.94	0.85	1.27	0.30								
6	8.24	25.61	5.52	9.65	3.97	4.34	2.33	1.18	1.53	0.43	1.08	0.18						
7	9.62	34.07	6.44	12.84	4.63	5.77	2.72	1.58	1.78	0.57	1.26	0.24						
8	10.99	43.63	7.36	16.45	5.30	7.39	3.11	2.02	2.04	0.72	1.44	0.31						
9	12.36	54.26	8.28	20.45	5.96	9.19	3.50	2.51	2.29	0.90	1.62	0.39						
10	13.74	65.95	9.20	24.86	6.62	11.17	3.88	3.05	2.55	1.10	1.80	0.47						
12			11.04	34.85	7.95	15.66	4.66	4.28	3.06	1.54	2.16	0.66	1.24	0.17				
14			12.88	46.36	9.27	20.83	5.44	5.69	3.57	2.04	2.52	0.88	1.45	0.23				
16			14.72	59.37	10.59	26.68	6.21	7.28	4.08	2.62	2.88	1.12	1.66	0.29				
18			16.56	73.84	11.92	33.18	6.99	9.06	4.59	3.25	3.24	1.40	1.86	0.36				
20					13.24	40.33	7.77	11.01	5.10	3.96	3.60	1.70	2.07	0.44				
22					14.57	48.11	8.54	13.14	5.61	4.72	3.96	2.03	2.28	0.53	1.48	0.18	1.03	0.08
24					15.89	56.53	9.32	15.44	6.12	5.55	4.32	2.38	2.49	0.62	1.61	0.22	1.13	0.09
26							10.10	17.90	6.63	6.43	4.68	2.76	2.69	0.72	1.75	0.25	1.22	0.11
28							10.87	20.54	7.14	7.38	5.04	3.17	2.90	0.82	1.88	0.29	1.32	0.12
30							11.65	23.33	7.65	8.38	5.40	3.60	3.11	0.94	2.01	0.33	1.41	0.14
32							12.43	26.30	8.16	9.45	5.76	4.06	3.31	1.05	2.15	0.37	1.51	0.15
34							13.20	29.42	8.67	10.57	6.12	4.54	3.52	1.18	2.28	0.41	1.60	0.17
36							13.98	32.71	9.18	11.75	6.48	5.05	3.73	1.31	2.42	0.46	1.69	0.19
38							14.76	36.15	9.69	12.99	6.84	5.58	3.93	1.45	2.55	0.51	1.79	0.21
40							15.53	39.75	10.20	14.28	7.21	6.13	4.14	1.59	2.69	0.56	1.88	0.23
42							16.31	43.51	10.71	15.63	7.57	6.71	4.35	1.75	2.82	0.61	1.98	0.26
44									11.22	17.04	7.93	7.32	4.56	1.90	2.95	0.66	2.07	0.28
46									11.73	18.50	8.29	7.94	4.76	2.07	3.09	0.72	2.16	0.30
48									12.24	20.02	8.65	8.60	4.97	2.24	3.22	0.78	2.26	0.33
50									12.75	21.59	9.01	9.27	5.18	2.41	3.36	0.84	2.35	0.35
55									14.02	25.76	9.91	11.06	5.70	2.88	3.69	1.00	2.59	0.42
60									15.30	30.26	10.81	13.00	6.21	3.38	4.03	1.18	2.82	0.50
65									16.57	35.10	11.71	15.07	6.73	3.92	4.36	1.37	3.06	0.57
70									17.85	40.26	12.61	17.29	7.25	4.50	4.70	1.57	3.29	0.66
75											13.51	19.65	7.77	5.11	5.04	1.78	3.53	0.75
80											14.41	22.14	8.28	5.76	5.37	2.01	3.76	0.84
85											15.31	24.77	8.80	6.44	5.71	2.25	4.00	0.94
90											16.21	27.54	9.32	7.16	6.04	2.50	4.23	1.05
95											17.11	30.44	9.84	7.91	6.38	2.76	4.47	1.16
100											18.01	33.47	10.35	8.70	6.71	3.03	4.70	1.28
110													11.39	10.38	7.39	3.62	5.17	1.52
120													12.43	12.20	8.06	4.25	5.65	1.79
130													13.46	14.15	8.73	4.93	6.12	2.07
140													14.50	16.23	9.40	5.66	6.59	2.38
150													15.53	18.44	10.07	6.43	7.06	2.70
160													16.57	20.78	10.74	7.24	7.53	3.05
170													17.60	23.25	11.41	8.11	8.00	3.41
180															12.09	9.01	8.47	3.79
190															12.76	9.96	8.94	4.19
200															13.43	10.95	9.41	4.61
220															14.77	13.07	10.35	5.50
240															16.12	15.35	11.29	6.46
260															17.46	17.80	12.23	7.49
280															18.80	20.42	13.17	8.59
300																	14.11	9.76
320																	15.05	11.00
340																	15.99	12.31
360																	16.94	13.69
380																	17.88	15.13
400																		
420																		
440																		
460																		
480																		
500																		

Shaded area represents velocities over 7 fps.
Use with caution where water hammer is a concern.

TECHNICAL

FRICION LOSS CHARTS

Irrigation Association Friction Loss Chart 2008

CLASS 160 PVC IPS PLASTIC PIPE

ASTM D-2241 (1120,1220) SDR 26 C=150 • PSI LOSS PER 100 FEET OF PIPE

Nominal Size Class ID Pipe OD Avg. Wall Min. Wall	Shown for convenience Class 315 1/2"		Class 200 3/4"		1"		1-1/4"		1-1/2"		2"		2-1/2"		3"		4"		6"	
	Velocity FPS	PSI LOSS	Velocity FPS	PSI LOSS	Velocity FPS	PSI LOSS	Velocity FPS	PSI LOSS	Velocity FPS	PSI LOSS	Velocity FPS	PSI LOSS	Velocity FPS	PSI LOSS	Velocity FPS	PSI LOSS	Velocity FPS	PSI LOSS	Velocity FPS	PSI LOSS
1	0.84	0.25	0.49	0.07	0.30	0.02	0.18	0.01	0.14	0.00										
2	1.68	0.90	0.99	0.24	0.59	0.07	0.36	0.02	0.27	0.01	0.17	0.00								
3	2.53	1.90	1.48	0.52	0.89	0.15	0.54	0.04	0.41	0.02	0.26	0.01								
4	3.37	3.24	1.97	0.88	1.18	0.25	0.71	0.07	0.54	0.04	0.35	0.01	0.24	0.00						
5	4.21	4.89	2.46	1.33	1.48	0.38	0.89	0.11	0.68	0.06	0.43	0.02	0.29	0.01						
6	5.05	6.86	2.96	1.86	1.77	0.54	1.07	0.16	0.81	0.08	0.52	0.03	0.35	0.01	0.24	0.00				
7	5.90	9.12	3.45	2.47	2.07	0.71	1.25	0.21	0.95	0.11	0.60	0.04	0.41	0.01	0.28	0.01				
8	6.74	11.68	3.94	3.17	2.36	0.91	1.43	0.27	1.09	0.14	0.69	0.05	0.47	0.02	0.32	0.01				
9	7.58	14.53	4.43	3.94	2.66	1.14	1.61	0.33	1.22	0.17	0.78	0.06	0.53	0.02	0.36	0.01				
10	8.42	17.66	4.93	4.79	2.96	1.38	1.78	0.40	1.36	0.21	0.86	0.07	0.59	0.03	0.40	0.01				
12	10.11	24.75	5.91	6.71	3.55	1.94	2.14	0.57	1.63	0.29	1.04	0.10	0.71	0.04	0.48	0.01				
14	11.79	32.93	6.90	8.93	4.14	2.58	2.50	0.76	1.90	0.39	1.21	0.13	0.82	0.05	0.55	0.02				
16	13.48	42.16	7.88	11.44	4.73	3.30	2.86	0.97	2.17	0.50	1.38	0.17	0.94	0.06	0.63	0.02	0.38	0.01		
18	15.16	52.44	8.87	14.23	5.32	4.10	3.21	1.20	2.44	0.62	1.56	0.21	1.06	0.08	0.71	0.03	0.43	0.01		
20			9.85	17.29	5.91	4.99	3.57	1.46	2.71	0.75	1.73	0.25	1.18	0.10	0.79	0.04	0.48	0.01		
22			10.84	20.63	6.50	5.95	3.93	1.74	2.99	0.90	1.90	0.30	1.29	0.12	0.87	0.04	0.53	0.01		
24			11.82	24.24	7.09	6.99	4.28	2.05	3.26	1.05	2.07	0.35	1.41	0.14	0.95	0.05	0.57	0.02		
26			12.81	28.11	7.68	8.11	4.64	2.38	3.53	1.22	2.25	0.41	1.53	0.16	1.03	0.06	0.62	0.02		
28			13.80	32.25	8.27	9.30	5.00	2.73	3.80	1.40	2.42	0.47	1.65	0.18	1.11	0.07	0.67	0.02		
30			14.78	36.64	8.87	10.57	5.35	3.10	4.07	1.59	2.59	0.53	1.76	0.21	1.19	0.08	0.72	0.02		
32					9.46	11.91	5.71	3.49	4.34	1.79	2.76	0.60	1.88	0.23	1.27	0.09	0.76	0.03	0.35	0.00
34					10.05	13.32	6.07	3.91	4.61	2.01	2.94	0.67	2.00	0.26	1.35	0.10	0.81	0.03	0.37	0.00
36					10.64	14.81	6.42	4.34	4.88	2.23	3.11	0.74	2.12	0.29	1.43	0.11	0.86	0.03	0.40	0.00
38					11.23	16.37	6.78	4.80	5.16	2.46	3.28	0.82	2.23	0.32	1.50	0.12	0.91	0.04	0.42	0.01
40					11.82	18.00	7.14	5.28	5.43	2.71	3.46	0.90	2.35	0.35	1.58	0.14	0.95	0.04	0.44	0.01
42					12.41	19.70	7.50	5.78	5.70	2.97	3.63	0.99	2.47	0.39	1.66	0.15	1.00	0.04	0.46	0.01
44					13.00	21.47	7.85	6.30	5.97	3.23	3.80	1.08	2.59	0.42	1.74	0.16	1.05	0.05	0.48	0.01
46					13.59	23.32	8.21	6.84	6.24	3.51	3.97	1.17	2.70	0.46	1.82	0.18	1.10	0.05	0.51	0.01
48					14.18	25.23	8.57	7.40	6.51	3.80	4.15	1.27	2.82	0.50	1.90	0.19	1.15	0.06	0.53	0.01
50					14.78	27.21	8.92	7.98	6.78	4.10	4.32	1.37	2.94	0.53	1.98	0.20	1.19	0.06	0.55	0.01
55							9.82	9.52	7.46	4.89	4.75	1.63	3.23	0.64	2.18	0.24	1.31	0.07	0.61	0.01
60							10.71	11.18	8.14	5.74	5.18	1.91	3.53	0.75	2.38	0.29	1.43	0.08	0.66	0.01
65							11.60	12.97	8.82	6.66	5.62	2.22	3.82	0.87	2.57	0.33	1.55	0.10	0.72	0.01
70							12.49	14.88	9.50	7.64	6.05	2.55	4.11	1.00	2.77	0.38	1.67	0.11	0.77	0.02
75							13.38	16.90	10.18	8.68	6.48	2.89	4.41	1.13	2.97	0.43	1.79	0.13	0.83	0.02
80							14.28	19.05	10.86	9.78	6.91	3.26	4.70	1.28	3.17	0.49	1.91	0.14	0.88	0.02
85									11.53	10.94	7.34	3.65	4.99	1.43	3.37	0.55	2.03	0.16	0.94	0.02
90									12.21	12.16	7.78	4.06	5.29	1.59	3.56	0.61	2.15	0.18	0.99	0.03
95									12.89	13.45	8.21	4.48	5.58	1.76	3.76	0.67	2.27	0.20	1.05	0.03
100									13.57	14.79	8.64	4.93	5.88	1.93	3.96	0.74	2.39	0.22	1.10	0.03
110									14.93	17.64	9.50	5.88	6.46	2.30	4.36	0.88	2.63	0.26	1.21	0.04
120											10.37	6.91	7.05	2.71	4.75	1.04	2.86	0.30	1.32	0.05
130											11.23	8.02	7.64	3.14	5.15	1.20	3.10	0.35	1.43	0.05
140											12.10	9.20	8.23	3.60	5.54	1.38	3.34	0.40	1.54	0.06
150											12.96	10.45	8.81	4.09	5.94	1.57	3.58	0.46	1.65	0.07
160											13.82	11.77	9.40	4.61	6.34	1.76	3.82	0.52	1.76	0.08
170											14.69	13.17	9.99	5.16	6.73	1.97	4.06	0.58	1.87	0.09
180													10.58	5.73	7.13	2.19	4.30	0.64	1.98	0.10
190													11.16	6.34	7.52	2.42	4.54	0.71	2.09	0.11
200													11.75	6.97	7.92	2.67	4.77	0.78	2.20	0.12
220													12.93	8.31	8.71	3.18	5.25	0.93	2.42	0.14
240													14.10	9.77	9.50	3.74	5.73	1.09	2.65	0.17
260															10.29	4.33	6.21	1.27	2.87	0.19
280															11.09	4.97	6.68	1.45	3.09	0.22
300															11.88	5.65	7.16	1.65	3.31	0.25
320															12.67	6.37	7.64	1.86	3.53	0.28
340															13.46	7.12	8.12	2.08	3.75	0.32
360															14.25	7.92	8.59	2.31	3.97	0.35
380																	9.07	2.56	4.19	0.39
400																	9.55	2.81	4.41	0.43
420																	10.03	3.08	4.63	0.47
440																	10.50	3.35	4.85	0.51
460																	10.98	3.64	5.07	0.56
480																	11.46	3.94	5.29	0.60
500																	11.94	4.25	5.51	0.65

Shaded areas represent velocities over 5 fps.
Use with caution where water hammer is a concern.

TECHNICAL

FRICITION LOSS CHARTS

Irrigation Association Friction Loss Chart 2008

CLASS 200 PVC IPS PLASTIC PIPE

ASTM D-2241 (1120,1220) SDR 21 C=150 • PSI LOSS PER 100 FEET OF PIPE

Nominal Size	Class 315		3/4"		1"		1-1/4"		1-1/2"		2"		2-1/2"		3"		4"		6"	
	Avg. ID	Pipe OD	Avg. Wall	Min. Wall	Velocity FPS	PSI LOSS	Velocity FPS	PSI LOSS	Velocity FPS	PSI LOSS	Velocity FPS	PSI LOSS	Velocity FPS	PSI LOSS	Velocity FPS	PSI LOSS	Velocity FPS	PSI LOSS	Velocity FPS	PSI LOSS
1	0.696	0.840	0.072	0.062	0.49	0.07	0.30	0.02	0.19	0.01	0.14	0.00								
2	0.910	1.050	0.070	0.060	0.99	0.24	0.60	0.07	0.37	0.02	0.28	0.01								
3	1.169	1.315	0.073	0.063	1.48	0.52	0.90	0.15	0.56	0.05	0.42	0.02								
4	1.482	1.660	0.089	0.079	1.97	0.88	1.19	0.26	0.74	0.08	0.56	0.04	0.36	0.01	0.24	0.01				
5	1.700	1.900	0.100	0.090	2.46	1.33	1.49	0.39	0.93	0.12	0.71	0.06	0.45	0.02	0.31	0.01				
6	2.129	2.375	0.123	0.113	2.96	1.86	1.79	0.55	1.11	0.17	0.85	0.09	0.54	0.03	0.37	0.01	0.25	0.00		
7	2.581	2.875	0.147	0.137	3.45	2.47	2.09	0.73	1.30	0.23	0.99	0.12	0.63	0.04	0.43	0.02	0.29	0.01		
8	3.146	3.500	0.177	0.167	3.94	3.17	2.39	0.94	1.49	0.30	1.13	0.15	0.72	0.05	0.49	0.02	0.33	0.01		
9	4.046	4.500	0.227	0.217	4.43	3.94	2.69	1.17	1.67	0.37	1.27	0.19	0.81	0.06	0.55	0.02	0.37	0.01		
10	5.955	6.625	0.335	0.316	4.93	4.79	2.99	1.42	1.86	0.45	1.41	0.23	0.90	0.08	0.61	0.03	0.41	0.01		
12					5.91	6.71	3.58	1.98	2.23	0.63	1.69	0.32	1.08	0.11	0.73	0.04	0.49	0.02		
14					6.90	8.93	4.18	2.64	2.60	0.83	1.98	0.43	1.26	0.14	0.86	0.06	0.58	0.02		
16					7.88	11.44	4.78	3.38	2.97	1.07	2.26	0.55	1.44	0.18	0.98	0.07	0.66	0.03	0.40	0.01
18					8.87	14.23	5.37	4.21	3.34	1.33	2.54	0.68	1.62	0.23	1.10	0.09	0.74	0.03	0.45	0.01
20					9.85	17.29	5.97	5.11	3.72	1.61	2.82	0.83	1.80	0.28	1.22	0.11	0.82	0.04	0.50	0.01
22					10.84	20.63	6.57	6.10	4.09	1.92	3.11	0.99	1.98	0.33	1.35	0.13	0.91	0.05	0.55	0.01
24					11.82	24.24	7.17	7.17	4.46	2.26	3.39	1.16	2.16	0.39	1.47	0.15	0.99	0.06	0.60	0.02
26					12.81	28.11	7.76	8.31	4.83	2.62	3.67	1.34	2.34	0.45	1.59	0.18	1.07	0.07	0.65	0.02
28					13.80	32.25	8.36	9.53	5.20	3.01	3.95	1.54	2.52	0.52	1.71	0.20	1.15	0.08	0.70	0.02
30					14.78	36.64	8.96	10.83	5.57	3.41	4.24	1.75	2.70	0.59	1.84	0.23	1.24	0.09	0.75	0.03
32							9.55	12.21	5.94	3.85	4.52	1.97	2.88	0.66	1.96	0.26	1.32	0.10	0.80	0.03
34							10.15	13.66	6.32	4.31	4.80	2.21	3.06	0.74	2.08	0.29	1.40	0.11	0.85	0.03
36							10.75	15.18	6.69	4.79	5.08	2.45	3.24	0.82	2.20	0.32	1.48	0.12	0.90	0.04
38							11.35	16.78	7.06	5.29	5.36	2.71	3.42	0.91	2.33	0.36	1.57	0.14	0.95	0.04
40							11.94	18.45	7.43	5.82	5.65	2.98	3.60	1.00	2.45	0.39	1.65	0.15	1.00	0.04
42							12.54	20.20	7.80	6.37	5.93	3.27	3.78	1.09	2.57	0.43	1.73	0.16	1.05	0.05
44							13.14	22.02	8.17	6.94	6.21	3.56	3.96	1.19	2.69	0.47	1.81	0.18	1.10	0.05
46							13.73	23.91	8.55	7.54	6.49	3.86	4.14	1.29	2.82	0.51	1.90	0.19	1.15	0.06
48							14.33	25.87	8.92	8.15	6.78	4.18	4.32	1.40	2.94	0.55	1.98	0.21	1.20	0.06
50							14.93	27.90	9.29	8.79	7.06	4.51	4.50	1.51	3.06	0.59	2.06	0.23	1.25	0.07
55									10.22	10.49	7.76	5.38	4.95	1.80	3.37	0.71	2.27	0.27	1.37	0.08
60									11.15	12.33	8.47	6.32	5.40	2.11	3.67	0.83	2.47	0.32	1.50	0.09
65									12.07	14.30	9.18	7.33	5.85	2.45	3.98	0.96	2.68	0.37	1.62	0.11
70									13.00	16.40	9.88	8.41	6.30	2.81	4.29	1.10	2.89	0.42	1.74	0.12
75									13.93	18.63	10.59	9.56	6.75	3.20	4.59	1.25	3.09	0.48	1.87	0.14
80									14.86	21.00	11.29	10.77	7.20	3.60	4.90	1.41	3.30	0.54	1.99	0.16
85											12.00	12.05	7.65	4.03	5.21	1.58	3.50	0.60	2.12	0.18
90											12.71	13.40	8.10	4.48	5.51	1.76	3.71	0.67	2.24	0.20
95											13.41	14.81	8.55	4.95	5.82	1.94	3.92	0.74	2.37	0.22
100											14.12	16.28	9.00	5.45	6.12	2.13	4.12	0.81	2.49	0.24
110											9.90	6.50	6.74	2.55	6.74	2.55	4.53	0.97	2.74	0.29
120											10.80	7.63	7.35	2.99	7.35	2.99	4.95	1.14	2.99	0.34
130											11.70	8.85	7.96	3.47	7.96	3.47	5.36	1.32	3.24	0.39
140											12.60	10.16	8.57	3.98	8.57	3.98	5.77	1.52	3.49	0.45
150											13.50	11.54	9.19	4.52	9.19	4.52	6.18	1.73	3.74	0.51
160											14.40	13.01	9.80	5.10	9.80	5.10	6.60	1.95	3.99	0.57
170													10.41	5.70	7.01	2.18	7.01	2.18	4.24	0.64
180													11.02	6.34	7.42	2.42	7.42	2.42	4.49	0.71
190													11.64	7.01	7.83	2.67	7.83	2.67	4.74	0.79
200													12.25	7.71	8.24	2.94	8.24	2.94	4.98	0.86
220													13.47	9.19	9.07	3.51	9.07	3.51	5.48	1.03
240													14.70	10.80	9.89	4.12	9.89	4.12	5.98	1.21
260															10.72	4.78	6.48	1.41	2.99	0.21
280															11.54	5.48	6.98	1.61	3.22	0.25
300															12.37	6.23	7.48	1.83	3.45	0.28
320															13.19	7.02	7.98	2.06	3.68	0.31
340															14.02	7.86	8.47	2.31	3.91	0.35
360															14.84	8.73	8.97	2.57	4.14	0.39
380																	9.47	2.84	4.37	0.43
400																	9.97	3.12	4.60	0.48
420																	10.47	3.42	4.83	0.52
440																	10.97	3.72	5.06	0.57
460																	11.46	4.04	5.29	0.62
480																	11.96	4.37	5.52	0.67
500																	12.46	4.72	5.75	0.72

Shaded areas represent velocities over 5 fps.
Use with caution where water hammer is a concern.

TECHNICAL

FRICION LOSS CHARTS

Irrigation Association Friction Loss Chart 2008 SCHEDULE 40 PVC IPS PLASTIC PIPE ASTM D-1785 (1120,1220) C=150 • PSI Loss Per 100 Feet of Pipe

Nominal Size Avg. ID Pipe OD Avg. Wall Min Wall	1/2"		3/4"		1"		1 1/4"		1 1/2"		2"		2 1/2"		3"		4"		6"		
	Velocity FPS	PSI LOSS	Velocity FPS	PSI LOSS	Velocity FPS	PSI LOSS	Velocity FPS	PSI LOSS	Velocity FPS	PSI LOSS	Velocity FPS	PSI LOSS	Velocity FPS	PSI LOSS	Velocity FPS	PSI LOSS	Velocity FPS	PSI LOSS	Velocity FPS	PSI LOSS	
1	1.13	0.50	0.63	0.12	0.39	0.04	0.22	0.01	0.16	0.00											
2	2.25	1.82	1.26	0.44	0.77	0.13	0.44	0.03	0.32	0.02	0.19	0.00									
3	3.38	3.85	1.89	0.94	1.16	0.28	0.66	0.07	0.48	0.03	0.29	0.01									
4	4.50	6.55	2.52	1.60	1.54	0.48	0.88	0.12	0.65	0.06	0.39	0.02	0.27	0.01							
5	5.63	9.91	3.16	2.42	1.93	0.73	1.10	0.19	0.81	0.09	0.49	0.03	0.34	0.01							
6	6.75	13.89	3.79	3.40	2.31	1.02	1.32	0.26	0.97	0.12	0.58	0.04	0.41	0.02	0.26	0.01					
7	7.88	18.48	4.42	4.52	2.70	1.36	1.54	0.35	1.13	0.16	0.68	0.05	0.48	0.02	0.31	0.01					
8	9.01	23.66	5.05	5.79	3.08	1.74	1.76	0.45	1.29	0.21	0.78	0.06	0.55	0.03	0.35	0.01					
9	10.13	29.43	5.68	7.20	3.47	2.17	1.99	0.56	1.45	0.26	0.88	0.08	0.61	0.03	0.40	0.01					
10	11.26	35.77	6.31	8.75	3.85	2.63	2.21	0.68	1.61	0.32	0.97	0.09	0.68	0.04	0.44	0.01					
12	13.51	50.14	7.57	12.27	4.62	3.69	2.65	0.95	1.94	0.44	1.17	0.13	0.82	0.05	0.53	0.02					
14	15.76	66.71	8.84	16.32	5.39	4.91	3.09	1.26	2.26	0.59	1.36	0.17	0.96	0.07	0.62	0.03					
16	18.01	85.42	10.10	20.90	6.17	6.29	3.53	1.62	2.58	0.76	1.56	0.22	1.09	0.09	0.71	0.03	0.41	0.01			
18	20.26	106.24	11.36	25.99	6.94	7.82	3.97	2.01	2.90	0.94	1.75	0.28	1.23	0.12	0.79	0.04	0.46	0.01			
20			12.62	31.59	7.71	9.51	4.41	2.45	3.23	1.14	1.95	0.33	1.36	0.14	0.88	0.05	0.51	0.01			
22			13.89	37.69	8.48	11.35	4.85	2.92	3.55	1.37	2.14	0.40	1.50	0.17	0.97	0.06	0.56	0.02			
24			15.15	44.28	9.25	13.33	5.29	3.43	3.87	1.60	2.34	0.47	1.64	0.20	1.06	0.07	0.61	0.02			
26			16.41	51.36	10.02	15.46	5.74	3.98	4.20	1.86	2.53	0.54	1.77	0.23	1.15	0.08	0.66	0.02			
28			17.67	58.91	10.79	17.73	6.18	4.56	4.52	2.13	2.73	0.62	1.91	0.26	1.23	0.09	0.71	0.02			
30			18.94	66.94	11.56	20.15	6.62	5.19	4.84	2.42	2.92	0.71	2.05	0.30	1.32	0.10	0.77	0.03			
32					12.33	22.71	7.06	5.85	5.16	2.73	3.12	0.80	2.18	0.34	1.41	0.12	0.82	0.03	0.36	0.00	
34					13.10	25.41	7.50	6.54	5.49	3.06	3.31	0.89	2.32	0.38	1.50	0.13	0.87	0.03	0.38	0.00	
36					13.87	28.24	7.94	7.27	5.81	3.40	3.51	0.99	2.46	0.42	1.59	0.14	0.92	0.04	0.40	0.01	
38					14.64	31.22	8.38	8.04	6.13	3.76	3.70	1.10	2.59	0.46	1.68	0.16	0.97	0.04	0.43	0.01	
40					15.41	34.33	8.82	8.84	6.46	4.13	3.89	1.21	2.73	0.51	1.76	0.18	1.02	0.05	0.45	0.01	
42					16.18	37.58	9.26	9.67	6.78	4.52	4.09	1.32	2.87	0.56	1.85	0.19	1.07	0.05	0.47	0.01	
44					16.95	40.96	9.71	10.54	7.10	4.93	4.28	1.44	3.00	0.61	1.94	0.21	1.12	0.06	0.49	0.01	
46					17.73	44.47	10.15	11.45	7.42	5.35	4.48	1.57	3.14	0.66	2.03	0.23	1.17	0.06	0.52	0.01	
48					18.50	48.12	10.59	12.39	7.75	5.79	4.67	1.69	3.28	0.71	2.12	0.25	1.23	0.07	0.54	0.01	
50					19.27	51.90	11.03	13.36	8.07	6.25	4.87	1.83	3.41	0.77	2.20	0.27	1.28	0.07	0.56	0.01	
55							12.13	15.94	8.88	7.45	5.36	2.18	3.75	0.92	2.42	0.32	1.40	0.08	0.62	0.01	
60							13.24	18.72	9.68	8.75	5.84	2.56	4.09	1.08	2.65	0.37	1.53	0.10	0.67	0.01	
65							14.34	21.72	10.49	10.15	6.33	2.97	4.44	1.25	2.87	0.43	1.66	0.11	0.73	0.02	
70							15.44	24.91	11.30	11.65	6.82	3.41	4.78	1.43	3.09	0.50	1.79	0.13	0.79	0.02	
75							16.54	28.31	12.10	13.23	7.30	3.87	5.12	1.63	3.31	0.56	1.91	0.15	0.84	0.02	
80							17.65	31.90	12.91	14.91	7.79	4.36	5.46	1.84	3.53	0.63	2.04	0.17	0.90	0.02	
85									13.72	16.69	8.28	4.88	5.80	2.06	3.75	0.71	2.17	0.19	0.95	0.03	
90									14.52	18.55	8.76	5.43	6.14	2.29	3.97	0.79	2.30	0.21	1.01	0.03	
95									15.33	20.50	9.25	6.00	6.48	2.53	4.19	0.87	2.42	0.23	1.07	0.03	
100									16.14	22.55	9.74	6.59	6.82	2.78	4.41	0.96	2.55	0.25	1.12	0.03	
110											10.71	7.87	7.51	3.31	4.85	1.14	2.81	0.30	1.23	0.04	
120											11.68	9.24	8.19	3.89	5.29	1.34	3.06	0.36	1.35	0.05	
130											12.66	10.72	8.87	4.52	5.73	1.56	3.32	0.41	1.46	0.06	
140											13.63	12.30	9.55	5.18	6.17	1.79	3.57	0.47	1.57	0.06	
150											14.61	13.97	10.24	5.89	6.61	2.03	3.83	0.54	1.68	0.07	
160											15.58	15.75	10.92	6.63	7.05	2.29	4.08	0.61	1.79	0.08	
170													11.60	7.42	7.50	2.56	4.34	0.68	1.91	0.09	
180													12.28	8.25	7.94	2.85	4.59	0.75	2.02	0.10	
190													12.97	9.12	8.38	3.15	4.85	0.83	2.13	0.11	
200													13.65	10.03	8.82	3.46	5.11	0.92	2.24	0.12	
220													15.01	11.96	9.70	4.13	5.62	1.09	2.47	0.15	
240													16.38	14.06	10.58	4.85	6.13	1.28	2.69	0.17	
260															11.46	5.63	6.64	1.49	2.92	0.20	
280															12.35	6.46	7.15	1.71	3.14	0.23	
300															13.23	7.34	7.66	1.94	3.37	0.26	
320															14.11	8.27	8.17	2.19	3.59	0.30	
340															14.99	9.25	8.68	2.45	3.81	0.33	
360																9.19	2.72	4.04	0.37		
380																9.70	3.01	4.26	0.41		
400																10.21	3.31	4.49	0.45		
420																10.72	3.62	4.71	0.49		
440																11.23	3.95	4.94	0.53		
460																11.74	4.28	5.16	0.58		
480																12.25	4.64	5.38	0.63		
500																12.76	5.00	5.61	0.68		

Shaded areas represent velocities over 5 fps.
Use with caution where water hammer is a concern.

TECHNICAL

FRICITION LOSS CHARTS

Irrigation Association Friction Loss Chart 2008 POLYETHYLENE PLASTIC PIPE ID CONTROLLED PE 3408 ASTM D 2239 C=140 • PSI LOSS PER 100 FEET OF PIPE

Nominal Size Avg. ID	1/2" 0.622		3/4" 0.824		1" 1.049		1-1/4" 1.380		1-1/2" 1.610		2" 2.067		2-1/2" 2.469		3" 3.068		4" 4.026	
	Velocity FPS	PSI LOSS	Velocity FPS	PSI LOSS	Velocity FPS	PSI LOSS	Velocity FPS	PSI LOSS	Velocity FPS	PSI LOSS	Velocity FPS	PSI LOSS	Velocity FPS	PSI LOSS	Velocity FPS	PSI LOSS	Velocity FPS	PSI LOSS
1	1.05	0.49	0.60	0.12	0.37	0.04	0.21	0.01	0.16	0.00								
2	2.11	1.76	1.20	0.45	0.74	0.14	0.43	0.04	0.31	0.02	0.19	0.01						
3	3.16	3.73	1.80	0.95	1.11	0.29	0.64	0.08	0.47	0.04	0.29	0.01						
4	4.22	6.35	2.40	1.62	1.48	0.50	0.86	0.13	0.63	0.06	0.38	0.02	0.27	0.01				
5	5.27	9.60	3.00	2.44	1.85	0.76	1.07	0.20	0.79	0.09	0.48	0.03	0.33	0.01				
6	6.33	13.46	3.61	3.43	2.22	1.06	1.29	0.28	0.94	0.13	0.57	0.04	0.40	0.02	0.26	0.01		
7	7.38	17.91	4.21	4.56	2.60	1.41	1.50	0.37	1.10	0.18	0.67	0.05	0.47	0.02	0.30	0.01		
8	8.44	22.93	4.81	5.84	2.97	1.80	1.71	0.47	1.26	0.22	0.76	0.07	0.54	0.03	0.35	0.01		
9	9.49	28.52	5.41	7.26	3.34	2.24	1.93	0.59	1.42	0.28	0.86	0.08	0.60	0.03	0.39	0.01		
10	10.55	34.67	6.01	8.82	3.71	2.73	2.14	0.72	1.57	0.34	0.95	0.10	0.67	0.04	0.43	0.01		
12			7.21	12.37	4.45	3.82	2.57	1.01	1.89	0.48	1.15	0.14	0.80	0.06	0.52	0.02		
14			8.41	16.45	5.19	5.08	3.00	1.34	2.20	0.63	1.34	0.19	0.94	0.08	0.61	0.03		
16			9.61	21.07	5.93	6.51	3.43	1.71	2.52	0.81	1.53	0.24	1.07	0.10	0.69	0.04	0.40	0.01
18			10.82	26.21	6.67	8.10	3.86	2.13	2.83	1.01	1.72	0.30	1.20	0.13	0.78	0.04	0.45	0.01
20			12.02	31.85	7.42	9.84	4.28	2.59	3.15	1.22	1.91	0.36	1.34	0.15	0.87	0.05	0.50	0.01
22					8.16	11.74	4.71	3.09	3.46	1.46	2.10	0.43	1.47	0.18	0.95	0.06	0.55	0.02
24					8.90	13.79	5.14	3.63	3.78	1.72	2.29	0.51	1.61	0.21	1.04	0.07	0.60	0.02
26					9.64	16.00	5.57	4.21	4.09	1.99	2.48	0.59	1.74	0.25	1.13	0.09	0.65	0.02
28					10.38	18.35	6.00	4.83	4.41	2.28	2.67	0.68	1.87	0.28	1.21	0.10	0.70	0.03
30					11.12	20.85	6.43	5.49	4.72	2.59	2.86	0.77	2.01	0.32	1.30	0.11	0.76	0.03
32					11.86	23.50	6.86	6.19	5.04	2.92	3.06	0.87	2.14	0.36	1.39	0.13	0.81	0.03
34					12.61	26.29	7.28	6.92	5.35	3.27	3.25	0.97	2.28	0.41	1.47	0.14	0.86	0.04
36							7.71	7.69	5.67	3.63	3.44	1.08	2.41	0.45	1.56	0.16	0.91	0.04
38							8.14	8.50	5.98	4.02	3.63	1.19	2.54	0.50	1.65	0.17	0.96	0.05
40							8.57	9.35	6.30	4.42	3.82	1.31	2.68	0.55	1.73	0.19	1.01	0.05
42							9.00	10.24	6.61	4.83	4.01	1.43	2.81	0.60	1.82	0.21	1.06	0.06
44							9.43	11.16	6.93	5.27	4.20	1.56	2.94	0.66	1.91	0.23	1.11	0.06
46							9.86	12.12	7.24	5.72	4.39	1.70	3.08	0.71	1.99	0.25	1.16	0.07
48							10.28	13.11	7.56	6.19	4.58	1.84	3.21	0.77	2.08	0.27	1.21	0.07
50							10.71	14.14	7.87	6.68	4.77	1.98	3.35	0.83	2.17	0.29	1.26	0.08
55							11.78	16.87	8.66	7.97	5.25	2.36	3.68	0.99	2.38	0.35	1.38	0.09
60							12.85	19.82	9.44	9.36	5.73	2.77	4.02	1.17	2.60	0.41	1.51	0.11
65									10.23	10.86	6.21	3.22	4.35	1.36	2.82	0.47	1.64	0.13
70									11.02	12.45	6.68	3.69	4.69	1.55	3.03	0.54	1.76	0.14
75									11.81	14.15	7.16	4.19	5.02	1.77	3.25	0.61	1.89	0.16
80									12.59	15.95	7.64	4.73	5.35	1.99	3.47	0.69	2.01	0.18
85									13.38	17.84	8.12	5.29	5.69	2.23	3.68	0.77	2.14	0.21
90											8.59	5.88	6.02	2.48	3.90	0.86	2.27	0.23
95											9.07	6.50	6.36	2.74	4.12	0.95	2.39	0.25
100											9.55	7.15	6.69	3.01	4.33	1.05	2.52	0.28
110											10.50	8.53	7.36	3.59	4.77	1.25	2.77	0.33
120											11.46	10.02	8.03	4.22	5.20	1.47	3.02	0.39
130											12.41	11.62	8.70	4.89	5.63	1.70	3.27	0.45
140											13.37	13.33	9.37	5.61	6.07	1.95	3.52	0.52
150													10.04	6.38	6.50	2.22	3.78	0.59
160													10.71	7.19	6.94	2.50	4.03	0.67
170													11.38	8.04	7.37	2.79	4.28	0.74
180													12.05	8.94	7.80	3.11	4.53	0.83
190													12.72	9.88	8.24	3.43	4.78	0.92
200													13.39	10.87	8.67	3.78	5.03	1.01
220															9.54	4.50	5.54	1.20
240															10.40	5.29	6.04	1.41
260															11.27	6.14	6.54	1.64
280															12.14	7.04	7.05	1.88
300															13.00	8.00	7.55	2.13
320															13.87	9.02	8.05	2.40
340																	8.56	2.69
360																	9.06	2.99
380																	9.57	3.30
400																	10.07	3.63
420																	10.57	3.98
440																	11.08	4.33
460																	11.58	4.71
480																	12.08	5.09
500																	12.59	5.49

Shaded areas represent velocities over 5 fps.
Use with caution where water hammer is a concern.

TECHNICAL

FRICION LOSS CHARTS

TABLE OF APPROXIMATE PRESSURE LOSSES FOR PIPE FITTINGS

Listed in Equivalent Feet of Pipe

Steel Fitting Type	1/2"	3/4"	1"	1-1/4"	1-1/2"	2"	2-1/2"	3"	4"	6"	8"
Coupling	0.6	0.8	1.0	1.2	1.5	2.0	2.5	3.0	4.0	6.0	8.0
Run of St. Tee	1.0	1.0	1.5	2.0	2.0	2.5	3.0	4.0	5.0	7.0	10.0
Tee, Side Outlet	3.0	4.5	5.0	7.0	9.0	11.0	13.0	16.0	20.0	31.0	42.0
Tee, Run Reduced 1/2"	1.5	2.5	3.0	4.0	5.0	6.0	7.0	8.0	12.0	16.0	20.0
Elbow, 90°	1.5	2.5	3.0	4.0	5.0	6.0	7.0	8.0	12.0	16.0	20.0
Elbow, 45°	0.75	1.0	1.3	1.7	2.0	2.5	3.0	3.5	5.0	7.5	10.0
Corporation Stop	9.0	9.0	9.0	9.0	9.0	9.0					
Curb Stop	6.0	6.0	7.0	7.0	8.0	8.0					
Plastic IPS or Copper Fitting Type	1/2"	3/4"	1"	1-1/4"	1-1/2"	2"	2-1/2"	3"	4"	6"	8"
Coupling	1.5	2.5	3.0	3.0	4.0	6.0	7.0	8.0	11.0	18.0	24.0
Run of St. Tee	2.5	3.0	4.0	5.0	6.0	8.0	9.0	11.0	15.0	21.0	28.0
Tee, Side Outlet	7.0	9.0	12.0	15.0	18.0	24.0	30.0	36.0	45.0	70.0	90.0
Tee, Run Reduced 1/2"	3.5	4.5	6.0	8.0	9.0	11.0	14.0	17.0	24.0	34.0	45.0
Elbow, 90°	3.5	4.5	6.0	8.0	9.0	11.0	14.0	17.0	24.0	34.0	45.0
Elbow, 34°	1.5	2.0	3.0	3.5	4.0	5.0	7.0	8.0	10.0	16.0	20.0

To use this chart, multiply the approximate "equivalent feet of pipe" value by the proper pipe pressure loss per 100 feet rating, then divide by 100. The result is the fitting loss in PSI.

Note: It is recommended that the above chart be used only when the manufacturers recommended pressure loss values are not available.

ACCESSORY PRESSURE LOSS CHARTS

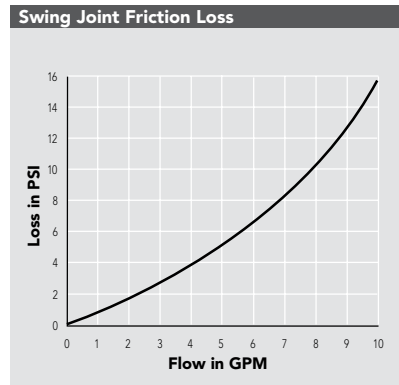
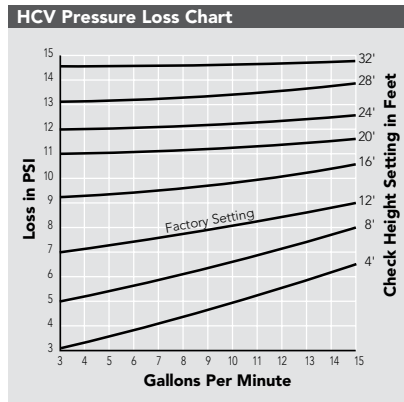

WIRE DATA

Standard Annealed Copper at 20° C

American Wire Gauge	Metric Wire Gauge	Diameter Mils	Diameter mm	Resistance Per mft Ohms	Resistance Per km Ohms
1		289.3	7.348	0.9239	0.4065
	7.0		7.000		0.4480
2		257.6	6.543	0.1563	0.5128
	6.0		6.000		0.6098
3		229.4	5.827	0.1971	0.6466
4		204.3	5.189	0.2485	0.8152
	5.0		5.000		0.08781
5		181.9	4.620	0.3134	1.028
	4.5		4.500		1.084
6		162.0	4.115	0.3952	1.297
	4.0		4.000		1.372
7		144.3	3.665	0.4981	1.634
	3.5		3.500		1.792
8		128.5	3.264	0.6281	2.061
	3.0		3.000		2.439
9		114.4	2.906	0.7925	2.600
10		101.9	2.588	0.9988	3.277
	2.5		2.500		3.512
11		90.7	2.30	1.26	4.14
12		80.8	2.05	1.59	5.21
	2.0		2.00		5.49
13		72.0	1.83	2.00	6.56
	1.8		1.80		6.78
14		64.1	1.63	2.52	8.28
	1.6		1.60		8.58
15		57.1	1.45	3.18	10.4
	1.4		1.40		11.2
16		50.8	1.29	4.02	13.2
	1.2		1.20		15.2
17		45.3	1.15	5.05	16.6
18		40.3	1.02	6.39	21.0
	1.0		1.000		22.0
19		35.9	0.912	8.05	26.4
	0.9		0.900		27.1
20		32.0	0.813	10.1	33.2

WIRE SIZING

Required Information

- Actual one-way length of wire between the controllers and the power source or the controllers and valves
- Allowable voltage loss along the wire circuit
- Accumulative current flowing through the wire section being sized in amperes

Resistance is calculated using this formula:

$$R = \frac{1000 \times AVL}{2L \times I}$$

- R* = Maximum Allowable Resistance of wire in ohms per 1000 feet
AVL = Allowable voltage loss
L = Wire length (one way)
I = Inrush current

AVL for controller power wire sizing is calculated by subtracting the minimum operating voltage required by the controller from the minimum available voltage at the power source.

AVL for valve wire sizing is calculated by subtracting minimum solenoid operating voltage from controller output voltage. This number will vary depending on the manufacturer and in some cases with line pressure.

Valve Wire Sizing Example:

Given: The distance from the controller to the valve is 1800 feet. The controller output is 24 V. The valve has a minimum operating voltage of 20 V and an inrush current of 370 mA (0.37 A).

$$R = \frac{1000 \times 4}{2(1800) \times 0.37}$$

$$R = \frac{4000}{1332}$$

$$R = 3.00 \text{ ohms/1000 feet}$$

So, wire resistance can not exceed 3.00 ohms per 1000 feet. Now go to table #1 and select the proper wire size. Since 16 gauge wire has more resistance than 3.00 ohms per 1000 feet, choose 14 gauge wire.

Table 2 is a quick reference and is set up to provide maximum wire runs given the information at the bottom of the table.

Table 1	
Resistance of Copper Wire	
Wire Size AWG No.	Resistance at 20° C (68° F) ohms per 1000 feet
18	6.39
16	4.02
14	2.52
12	1.59
10	1.00
8	0.63
6	0.40
4	0.25

Table 2							
Valve Wire Sizing							
(Maximum One-Way Distance in Feet Between Controller and Valve)							
Ground Wire	Control Wire						
	18	16	14	12	10	8	6
18	850	1040	1210	1350	1460	1540	1590
16	1040	1340	1650	1920	2150	2330	2440
14	1210	1650	2150	2630	3080	3450	3700
12	1350	1920	2630	3390	4170	4880	5400
10	1460	2150	3080	4170	5400	6670	7690
8	1540	2330	3450	4880	6670	8700	10530
6	1590	2440	3700	5400	7690	10530	13330

Heavy-duty solenoid: 24 VAC,
370 mA inrush current, 190 mA holding current, 60 cycles;
475 mA inrush current, 230 mA holding current, 50 cycles

ADDITIONAL DATA

REFERENCE CHART

Approximate Number of Wires to be Installed in Conduit or Tubing

Maximum Number of Wires in Conduit or Sleeveing

Wire Size (AWG)	1/2	3/4	1	1-1/4	1-1/2	2	2-1/2	3	3-1/2	4	5	6	Wire Size (AWG)
18	6	12	20	35	49	80	110	175					18
16	5	10	16	30	42	67	97	150					16
14	4	6	10	18	25	40	56	88	120	150			14
12	3	5	7	15	20	33	50	75	102	130	205		12
10	1	3	6	13	16	27	40	63	85	110	170		10
8	1	2	4	6	9	16	25	35	50	65	105	150	8
6	1	1	3	3	5	10	15	22	32	40	63	92	6
4		1	1	2	4	7	10	16	24	30	48	70	4
2		1	1	2	2	5	9	12	18	22	36	54	2
0			1	1	2	3	5	8	12	15	24	36	0
00			1	1	1	2	4	7	10	14	21	31	00
000				1	1	2	3	6	8	11	18	26	000
0000				1	1	1	2	5	7	10	15	22	0000

ESTIMATING PIPE SIZE

Nominal Pipe Size	Approximate String Length in Inches		
	Copper Pipe	Galvanized (Sch. 40 Steel)	PVC Pipe
1/2"	2"	2-5/8"	2-5/8"
5/8"	2-3/8"		
3/4"	2-3/4"	3-5/16"	3-5/16"
1"	3-1/2"	4-1/8"	4-1/8"
1-1/4"	4-5/16"	5-3/16"	5-3/16"
1-1/2"	5-1/8"	6"	6"
2"	6-3/4"	7-7/16"	7-7/16"

To determine the nominal size of a pipe, wrap a string around the pipe and compare its length to the chart above.

CLIMATE ETp TABLE

Climate*	Inches Daily
Cool Humid	0.10 to 0.15
Cool Dry	0.15 to 0.20
Warm Humid	0.15 to 0.20
Warm Dry	0.20 to 0.25
Hot Humid	0.20 to 0.30
Hot Dry	0.30 to 0.45
	↑ Worst case

* "Cool" equals under 70° F as an average mid-summer high.
 "Warm" equals between 70° and 90° F as mid-summer highs.
 "Hot" equals over 90° F. "Humid" equals over 50% as average mid-summer relative humidity (dry=under 50%).



GET INTO THE SWING, VISIT
WWW.HUNTERGOLF.COM

PLAY ON



Hunter[®]
GOLF

STATEMENT OF WARRANTY

Hunter Industries Incorporated ("Hunter") warrants the following products to be free of defects in materials or workmanship under normal use for a period of two (2) years from the original date of manufacture: PGP-ADJ®, PGJ, MP Rotator family, PS family, PS Ultra family, Spray Nozzles, PCN, PCB, AFB, HPV, PGV family, SRV, X-Core family, Pro-C family, ROAM, NODE, WVP, WVS, PACZ, PCZ, AVB, PSR, HCV, SJ, HFT family, SBE family, RZWS, and ET System. Hunter warrants the following products to be free of defects in materials or workmanship under normal use for a period of three (3) years from the original date of manufacture: PGP Ultra family. Hunter warrants the following products to be free of defects in materials or workmanship under normal use for a period of one (1) year from the original date of manufacture: SRM family, Micro Sprays and Stream Drippers. Hunter warrants the following products to be free of defects in materials or workmanship under normal use for a period of five (5) years from the original date of manufacture: I-20, I-25, I-35, I-40, I-60 and I-90 families, Pro-Spray® family, Pro-Spray® PRS30 family, and Pro-Spray® PRS40 family, G-Spray, I-Core/Dual family and ACC controller families, ICD Decoder Products, ICR Remotes, IMMS™ Central Control Products, "Clik" Sensors, Solar-Sync, HQ, ICV plastic, and IBV brass valves, ICZ and PLD tubing, ST Rotors. Hunter warrants the following products to be free of defects in material and workmanship under normal use for a period of ten (10) years from the original date of manufacture: Wireless Rain Clik and Wireless Solar Sync. If a defect in a Hunter product is discovered during the applicable warranty period, Hunter will repair or replace, at its option, the product or the defective part. This warranty does not extend to repairs, adjustments, or replacement of a Hunter product or part that results from misuse, negligence, alteration, modification, tampering, or improper installation and/or maintenance of the product. This warranty extends only to the original installer of the Hunter product. If a defect arises in a Hunter product or part during the warranty period, you should contact your local Hunter Authorized Distributor.

HUNTER'S OBLIGATION TO REPAIR OR REPLACE ITS PRODUCTS AS SET FORTH ABOVE IS THE SOLE AND EXCLUSIVE WARRANTY SET FORTH BY HUNTER. THERE ARE NO OTHER WARRANTIES, EXPRESSED OR IMPLIED, INCLUDING WARRANTIES OF MERCHANTABILITY AND FITNESS FOR A PARTICULAR PURPOSE. HUNTER WILL NOT BE LIABLE TO ANY PARTY IN STRICT LIABILITY, TORT, CONTRACT, OR ANY OTHER MANNER FOR DAMAGES CAUSED OR CLAIMED TO BE CAUSED AS A RESULT OF ANY DESIGN OR DEFECT IN HUNTER'S PRODUCTS, OR FOR ANY SPECIAL, INCIDENTAL OR CONSEQUENTIAL DAMAGES OF ANY NATURE.

If you have any questions concerning the warranty or its application, please write to:
Marketing Department, Hunter Industries Incorporated,
1940 Diamond Street, San Marcos, CA 92078, U.S.A.

ASAE CERTIFICATION STATEMENT

Hunter Industries Incorporated certifies that pressure, flow rate, and radius data for these products were determined and listed in accordance with ASAE Standard S398.1, Procedure for Sprinkler Testing and Performance Reporting, and are representative of performance of production sprinklers at the time of publication. Actual product performance may differ from the published specifications due to normal manufacturing variations and sample selection. All other specifications are solely the recommendation of Hunter Industries Incorporated.

Hunter[®]
THE IRRIGATION INNOVATORS

2012

PRODUCT CATALOG

ROTORS SPRAYS MP ROTATOR VALVES CONTROLLERS CENTRAL CONTROL SENSORS DRIP/MICRO



www.hunterindustries.com

U.S.A. Headquarters and Manufacturing
1940 Diamond Street
San Marcos, CA 92078
Tel: (1) 760-744-5240
Fax: (1) 760-744-7461
Technical Help: (1) 760-591-7383

Mexico Manufacturing
ISO 9001:2008 Certified
Calle Nordika #8615
Parque Industrial Nordika
Tijuana, B.C., Mexico C.P. 22709
Tel: (52) 664-903-1300
Fax: (52) 664-903-8078

Worldwide Offices
Australia
8 The Parade West
Kent Town, South Australia 5067
Tel: (61) 8-8363-3599
Fax: (61) 8-8363-3687

Europe
Avda. Diagonal 523, 5°-2°
Edificio Atalaya
08029 Barcelona, Spain
Tel: (34) 9-34-94-88-81
Fax: (34) 9-34-19-76-76

Middle East
P.O. Box 211303
Amman 11121, Jordan
Tel: (962) 6-515-2882
Fax: (962) 6-515-2992

China
B1618, Huibin Office Bldg.
No.8, Beichen Dong Street
Beijing 100101, China
Tel1/Fax: (86) 10-84975146
Tel2: (86) 13-901321516

Hunter[®]
THE IRRIGATION INNOVATORS

 PLEASE RECYCLE

LIT-600 A 08/11